

M2-9040/M2-9041

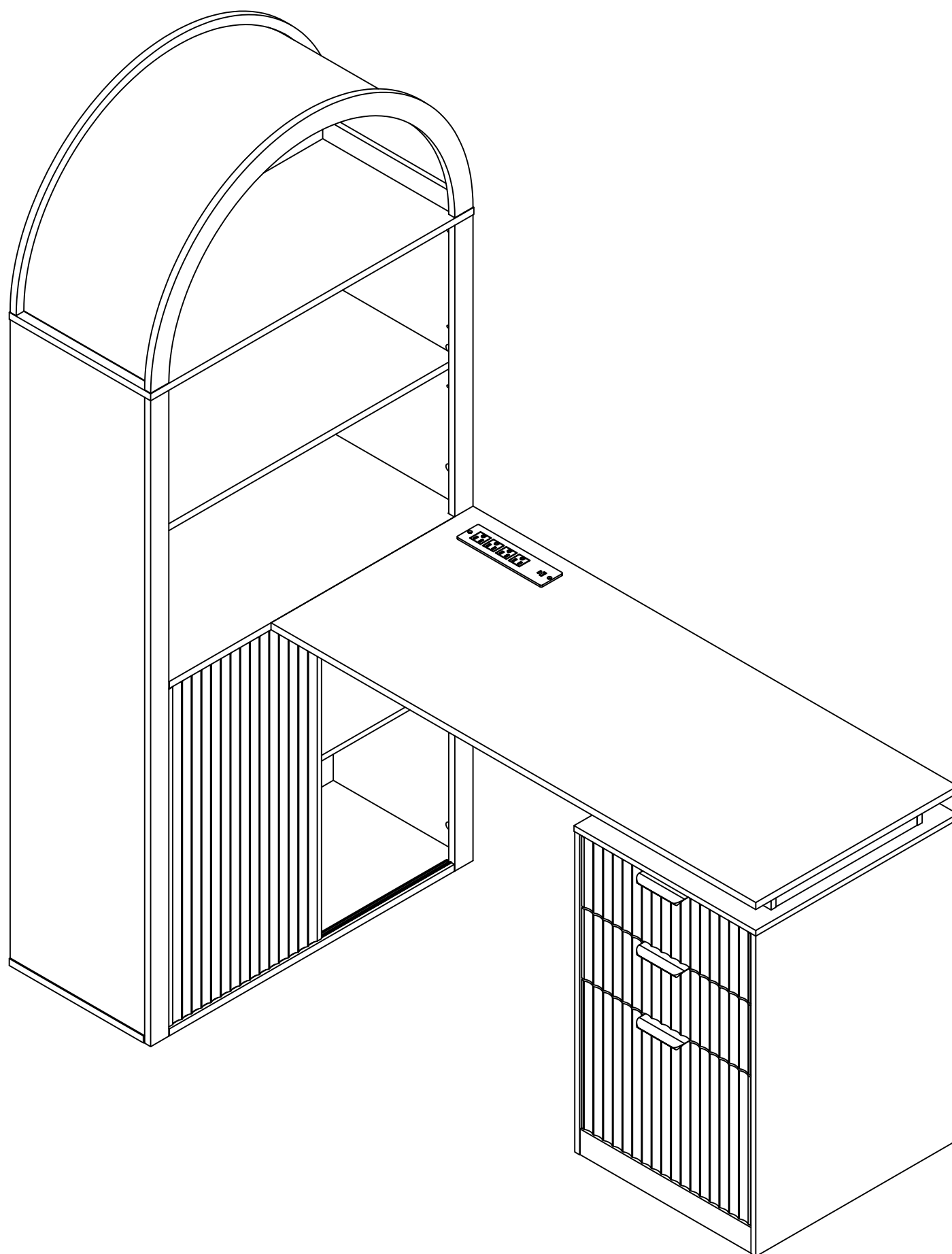

**ASSEMBLY
INSTRUCTIONS**

NOTICE

IMPORTANT, RETAIN FOR FUTURE REFERENCE: READ CAREFULLY
WICHTIG, FÜR SPÄTERE NACHSCHLAGE AUFBEWAHREN: SORGFÄLTIG LESEN
IMPORTANTE, GUARDAR PARA REFERENCIA FUTURA: LEER ATENTAMENTE
IMPORTANTE, CONSERVARE PER RIFERIMENTI FUTURI: LEGGERE ATTENTAMENTE
IMPORTANT, À CONSERVER POUR RÉFÉRENCE FUTURE : LIRE ATTENTIVEMENT

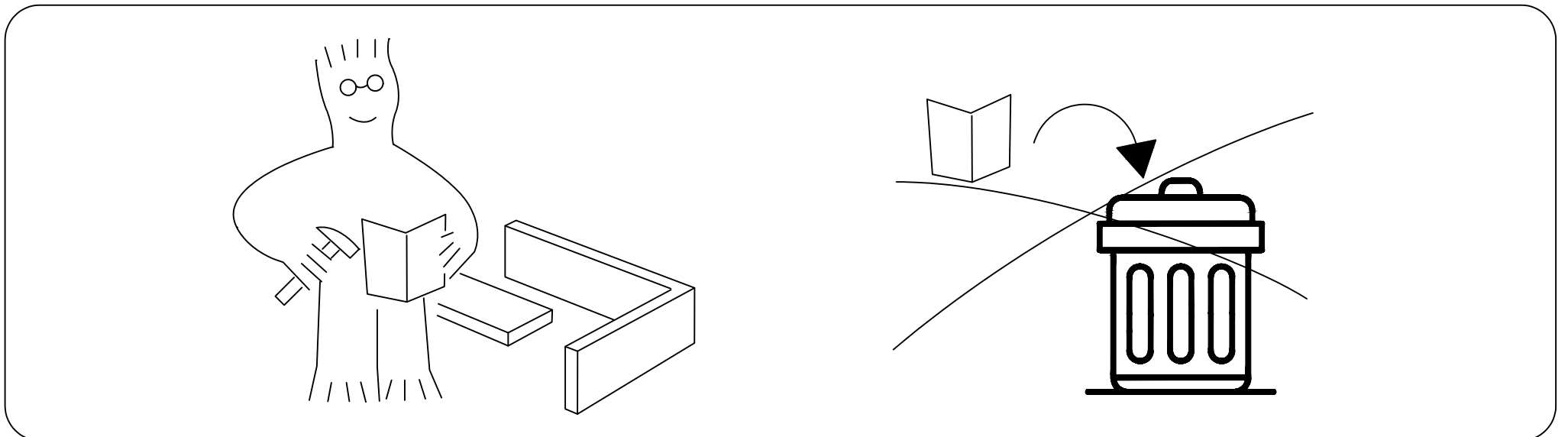

Assemble on a flat, clean and soft surface.
Auf einer flachen, sauberen und weichen Oberfläche zusammenbauen.
Assembler sur une surface plate, propre et douce.
Assemblare su una superficie piatta, pulita e morbida.
Ensamblar sobre una superficie plana, limpia y suave.

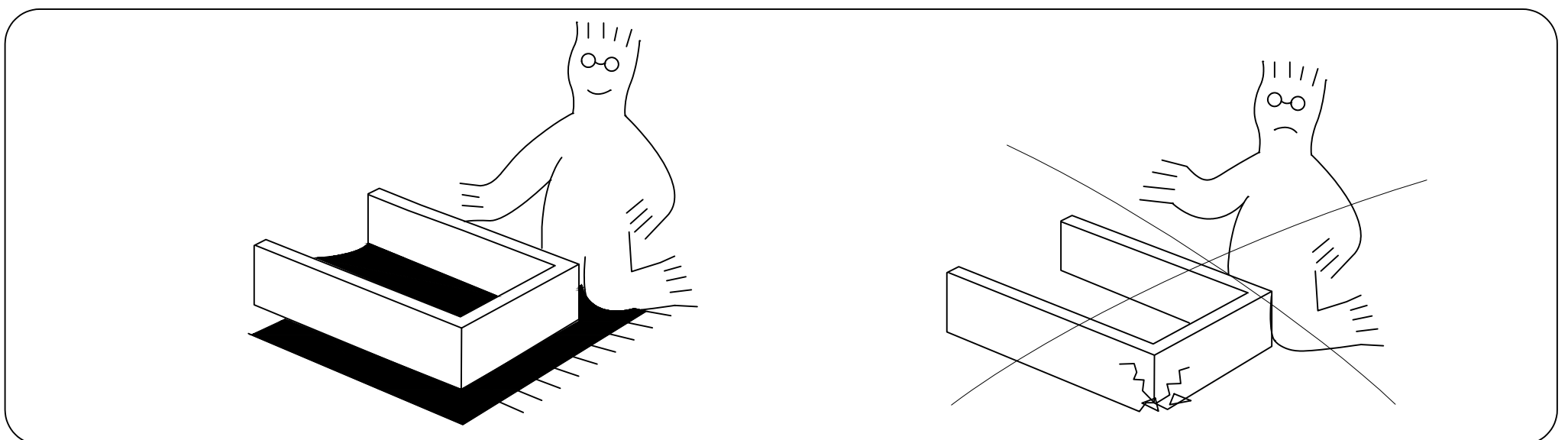

Professional installation is highly recommended.
Eine professionelle Installation wird dringend empfohlen.
Une installation professionnelle est fortement recommandée.
Si raccomanda vivamente l'installazione professionale.
Se recomienda altamente la instalación profesional.

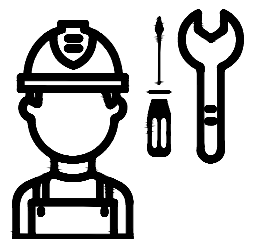

Periodically Check That All Components Are Tightly Secured.
Überprüfen Sie Regelmäßig, Dass Alle Komponenten Fest Gesichert Sind.
Vérifiez Périodiquement Que Tous Les Composants Sont Bien Fixés.
Controllare Periodicamente Che Tutti I Componenti Siano Ben Fissati.
Verifique Periódicamente Que Todos Los Componentes Estén Bien Asegurados.

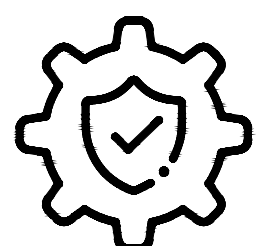

It is recommended that multiple people assemble this product.
 Es wird empfohlen, dass mehrere Personen dieses Produkt zusammenbauen.
 Il est recommandé que plusieurs personnes assemblent ce produit.
 Si raccomanda che più persone assemblino questo prodotto.
 Se recomienda que varias personas ensamblen este producto.

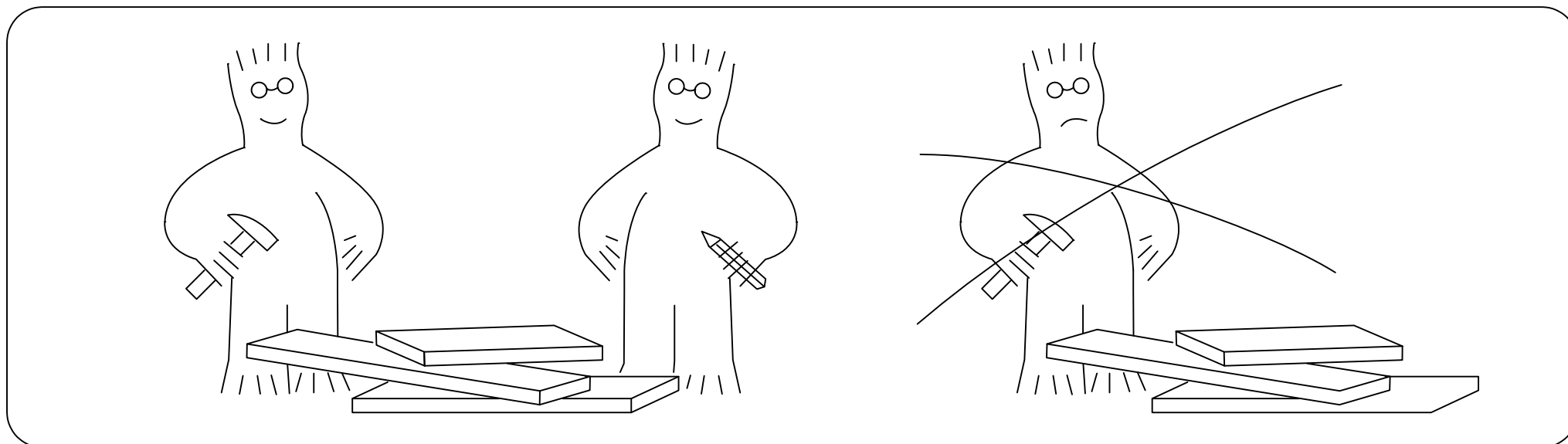

Serious or fatal crushing injuries can occur from furniture tip-over. Always secure this furniture to the wall using tip-over restraints.

Schwere oder tödliche Quetschverletzungen können durch das Umkippen von Möbeln verursacht werden. Sichern Sie diese Möbel immer mit Kipp-Sicherungen an der Wand.

Des blessures graves ou mortelles par écrasement peuvent survenir en cas de basculement de meubles. Fixez toujours ces meubles au mur à l'aide de dispositifs anti-basculement.

Lesioni gravi o mortali da schiacciamento possono verificarsi a causa del ribaltamento dei mobili. Fissare sempre questi mobili alla parete utilizzando i sistemi di blocco anti-ribaltamento.

Pueden ocurrir lesiones graves o fatales por aplastamiento debido al volcamiento de muebles. Siempre asegure este mueble a la pared utilizando dispositivos anti-vuelco.

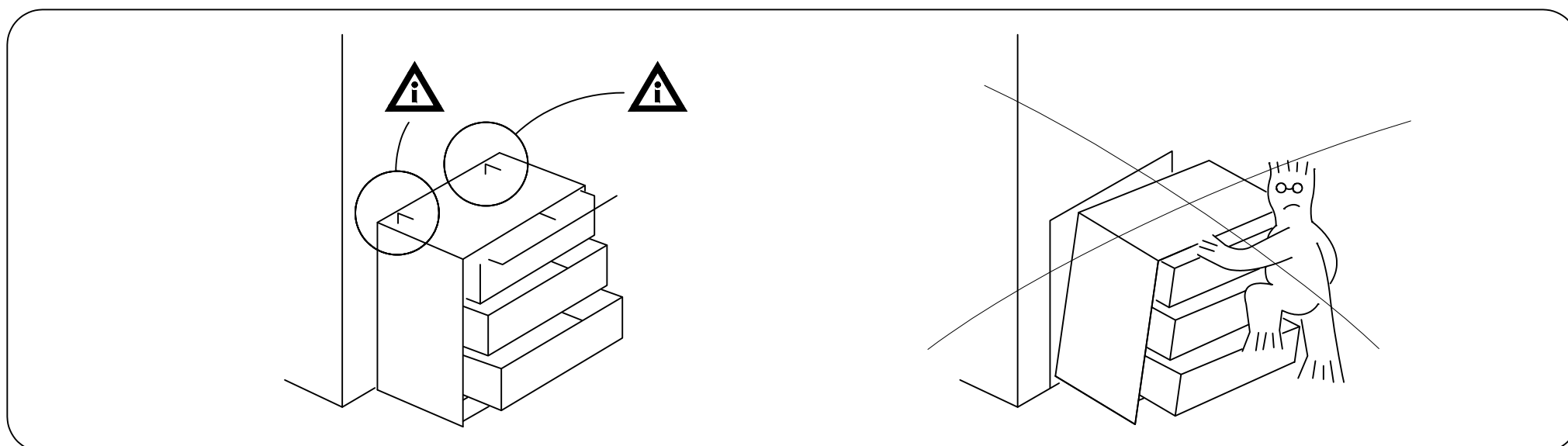

Please have the following auxiliary tools ready:

Bitte haben Sie die folgenden Hilfswerkzeuge bereit:

Veuillez avoir les outils auxiliaires suivants à portée de main:

Si prega di avere pronti i seguenti strumenti ausiliari:

Por favor, tenga listos las siguientes herramientas auxiliares:

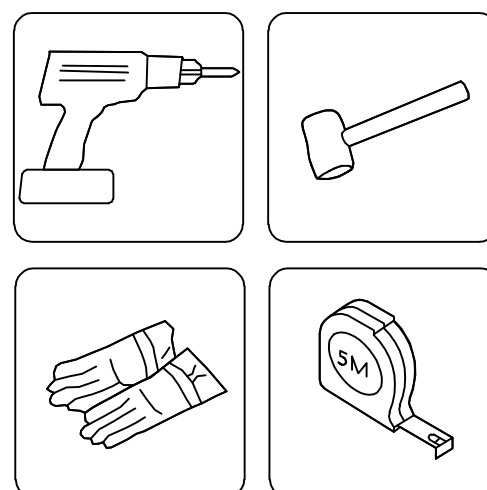

USING CAM LOCK AND QUICKFIT
 VERWENDUNG VON NOCKENSCHL OSS UND QUICKFIT
 UTILISATION DE SERRURE À CAME ET QUICKFIT
 USO DISERRATURA A LEVA E QUICKFIT
 USANDO EL CIERRE DE LEVAY QUICKFIT

Tighten QuickFit until the shoulder is flush with the panel. Do not overtighten or undertighten.
 Ziehen Sie den Quickfit an, bis die Schulter bündig mit der Platte ist. Nicht zu fest oder zu locker anziehen.
 Serrez le quickfit jusqu'à ce que l'épaule soit affleurant avec le panneau. Ne serrez pas trop ou trop peu.
 Stringere il quickfit fino a quando la spalla è a filo con il pannello. Non stringere troppo o troppo poco.
 Apriete el quickfit hasta que el hombro esté al ras con el panel. No apriete demasiado ni demasiado poco.

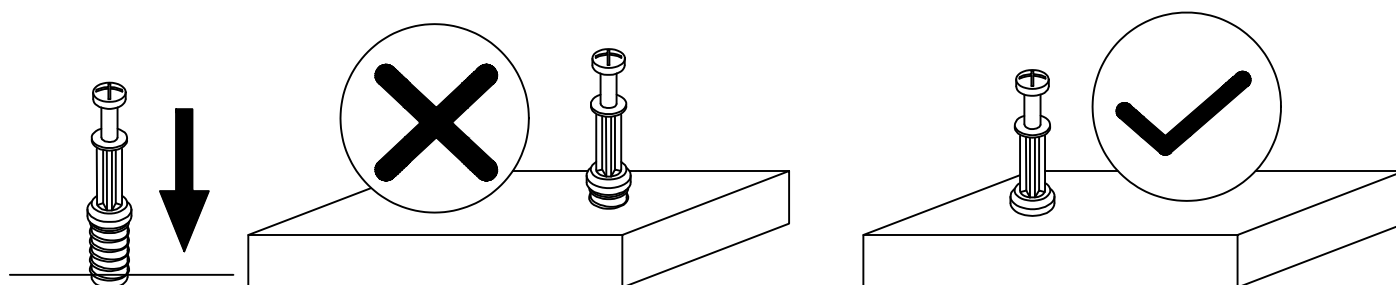

When fitting the cam lock, ensure the starting position is correct before inserting the connecting QuickFit.

Stellen Sie beim Einbau des Nockenschloss sicher, dass die Startposition korrekt ist, bevor Sie den verbindenden Quickfit einsetzen.

Lors de la pose du serrure à came, assurez-vous que la position de départ est correcte avant d'insérer le quickfit de connexion.

Quando si monta il serratura a leva, assicurarsi che la posizione di partenza sia corretta prima di inserire il quickfit di collegame to.

Al instalar el cierre de leva, asegúrese de que la posición inicial sea correcta antes de insertar el quickfit de conexión.

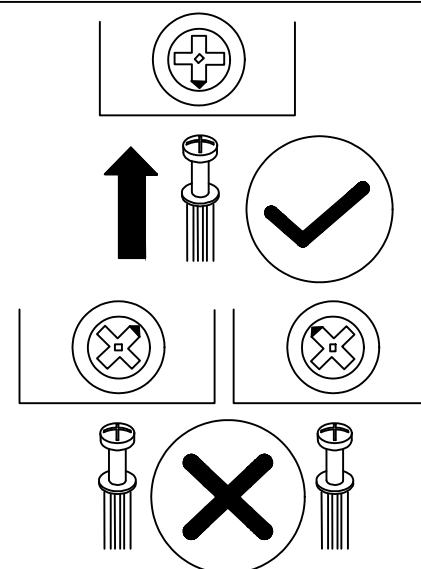

The QuickFit head should be in the center of the cam lock when the two panels are joined. The cam lock should be inserted before the QuickFit. Turn the cam lock clockwise to tighten.

Der Quickfit-Kopf sollte sich in der Mitte des Nockenschloss befinden, wenn die beiden Platten verbunden sind. Der Nockenschloss sollte vor dem Quickfit eingesetzt werden. Drehen Sie den Nockenschloss im Uhrzeigersinn, um ihn zu befestigen.



La tête du quickfit doit être au centre du serrure à came lorsque les deux panneaux sont assemblés. Le serrure à came doit être inséré avant le quickfit. Tournez le serrure à came dans le sens des aiguilles d'une montre pour le serrer.

La testa del quickfit dovrebbe essere al centro del serratura a leva quando i due pannelli sono uniti, il serratura a leva deve essere inserito prima del quickfit. Ruotare il serratura a leva in senso orario per stringere.

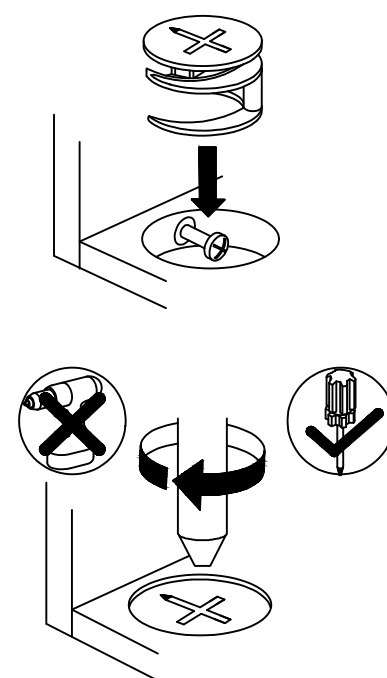
La cabeza del quickfit debe estar en el centro del cam lock cuando los dos paneles estén unidos. El cierre de leva debe insertarse antes del quickfit. Gire el cierre de leva en sentido horario para apretar.

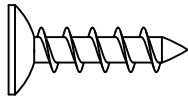
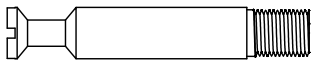
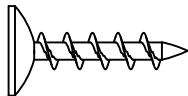

PARTS

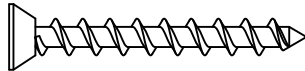
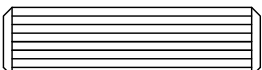
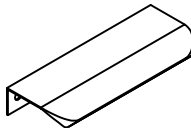
Item no. Nr. N °d article Articolo No. Artículo No	Reference Image Referenzbild Image de référence Immagine di riferimento Imagen de referencia	Qty Menge Qté. Qtà Cant.	Item no. Nr. N °d article Articolo No. Artículo No	Reference Image Referenzbild Image de référence Immagine di riferimento Imagen de referencia	Qty Menge Qté. Qtà Cant.
(A)	 Ø15X9.5mm	X85 +3	(E)	 Ø3.5X12mm	X50 +3
(B)	 Ø6.5X35mm	X82 +3	(F)	 Ø3X12mm	X6 +1
(C)	 Ø6X30mm	X40 +3	(G)	 Ø4X35mm	X37 +2
(D)	 Ø8X30mm	X20 +2	(H)	 128X38X17mm	X3

PARTS

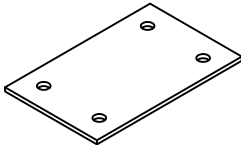
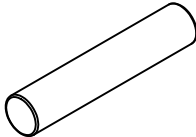
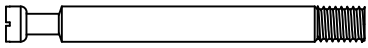
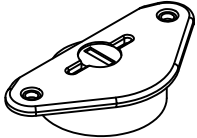
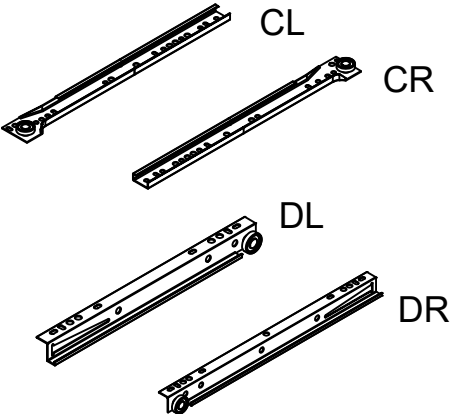
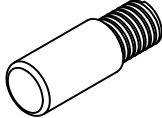
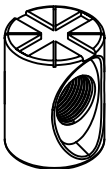
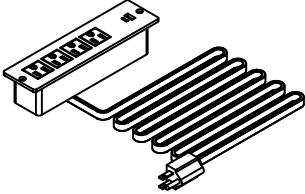
Item no. Nr . N °d article Articolo No. Artículo No	Reference Image Referenzbild Image de référence Immagine di riferimento Imagen de referencia	Qty Menge Qté. Qtà Cant.	Item no. Nr . N °d article Articolo No. Artículo No	Reference Image Referenzbild Image de référence Immagine di riferimento Imagen de referencia	Qty Menge Qté. Qtà Cant.
I		X2	M		X4
J	 Ø6.5X60mm	X3 +1	N		X2
K	 350mm	X3	O	 Ø6X17mm	X1
L		X3 +1	P		X1

PARTS

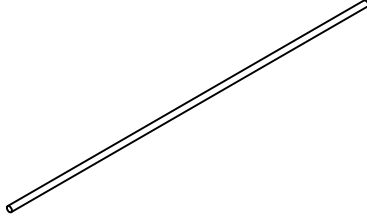
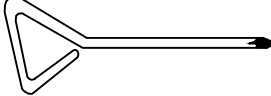
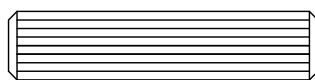
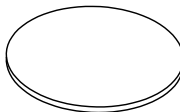
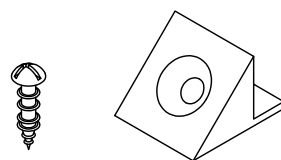
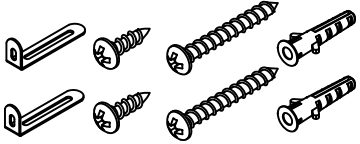
Item no. Nr . N °d article Articolo No. Artículo No	Reference Image Referenzbild Image de référence Immagine di riferimento Imagen de referencia	Qty Menge Qté. Qtà Cant.	Item no. Nr . N °d article Articolo No. Artículo No	Reference Image Referenzbild Image de référence Immagine di riferimento Imagen de referencia	Qty Menge Qté. Qtà Cant.
Q		X2	U	 70X30X5mm	X1
R	 Ø8X40mm	X2 +1	V	 Ø21mm	X42 +3
S		X20 +2			
T		X1			

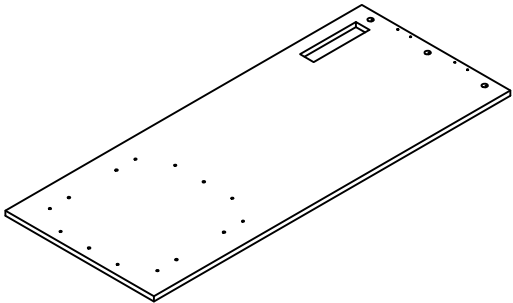
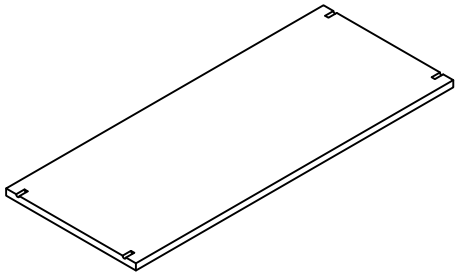
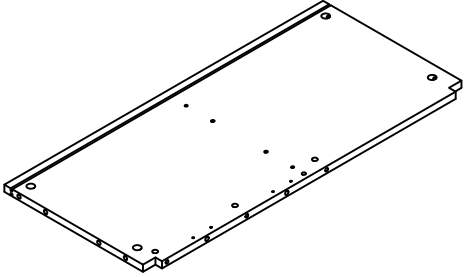
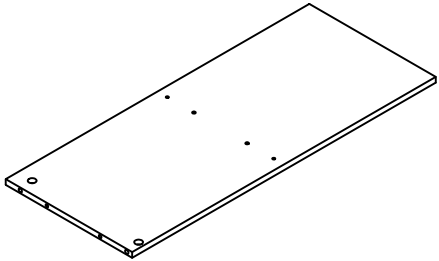
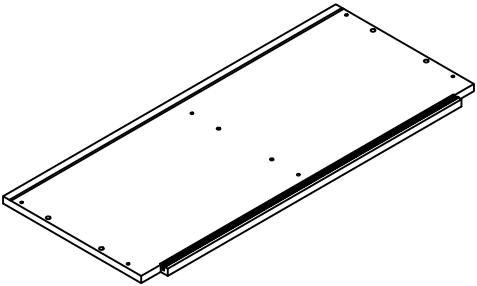
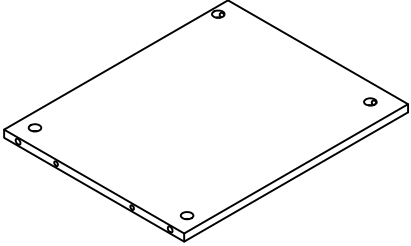
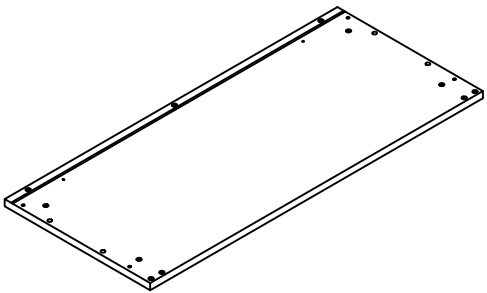
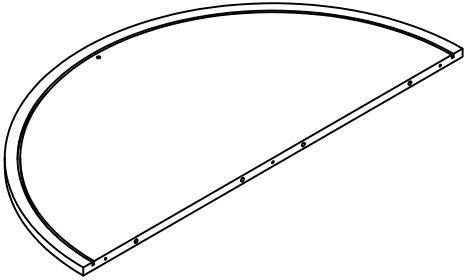
Item no. Nr . N °d article Articolo No. Artículo No	Reference Image Referenzbild Image de référence Immagine di riferimento Imagen de referencia	Qty Menge Qté. Qtà Cant.	Item no. Nr . N °d article Articolo No. Artículo No	Reference Image Referenzbild Image de référence Immagine di riferimento Imagen de referencia	Qty Menge Qté. Qtà Cant.
1		X1	5		X1
2		X1	6		X1
3		X1	7		X2
4		X1	8		X1

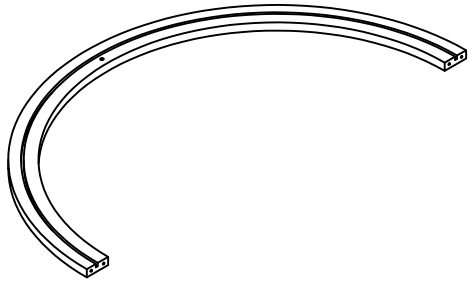
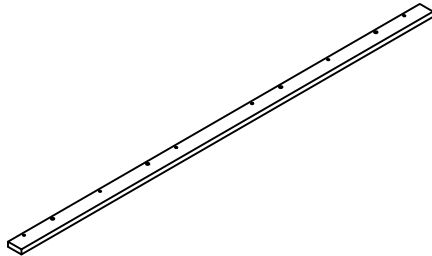
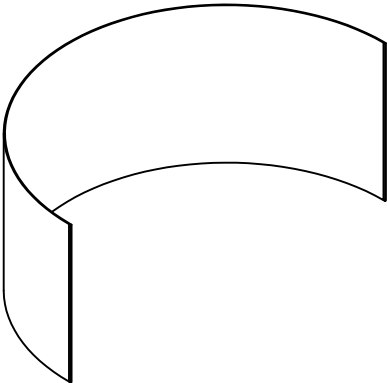
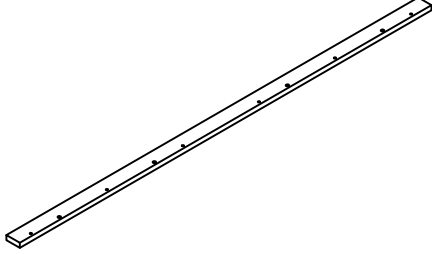
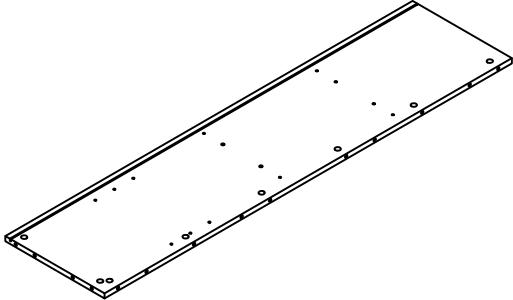
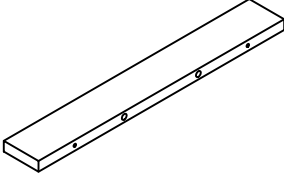
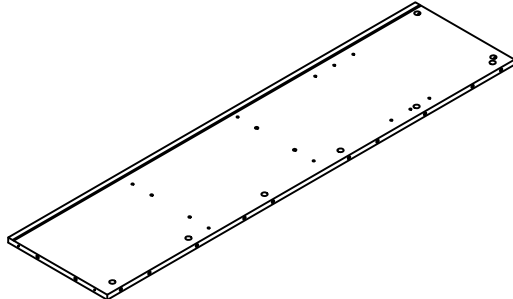
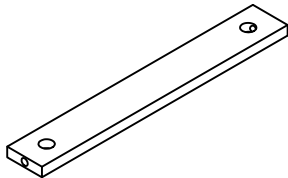
Item no. Nr. N °d article Articolo No. Artículo No	Reference Image Referenzbild Image de référence Immagine di riferimento Imagen de referencia	Qty Menge Qté. Qtà Cant.	Item no. Nr. N °d article Articolo No. Artículo No	Reference Image Referenzbild Image de référence Immagine di riferimento Imagen de referencia	Qty Menge Qté. Qtà Cant.
9		X1	13		X1
10		X1	14		X1
11		X1	15		X2
12		X1	16		X1

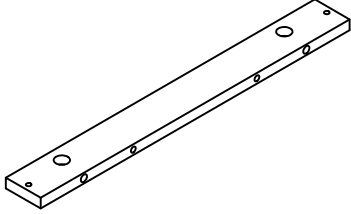
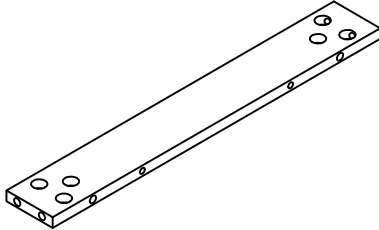
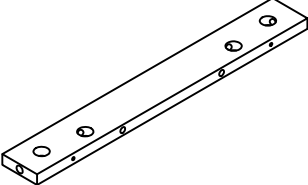
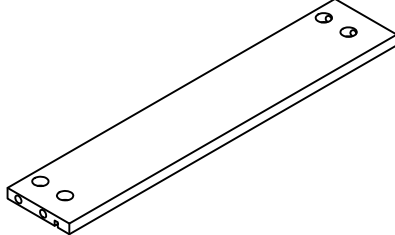
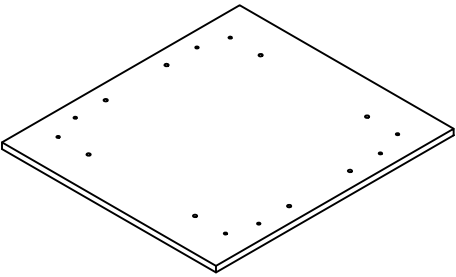
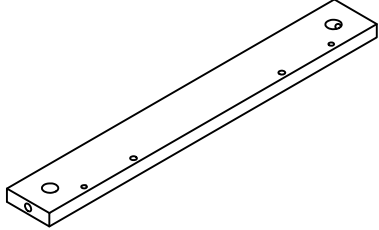
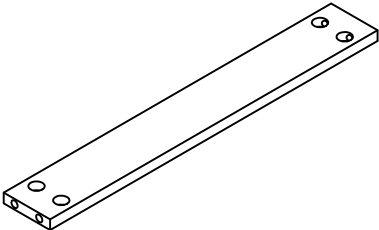
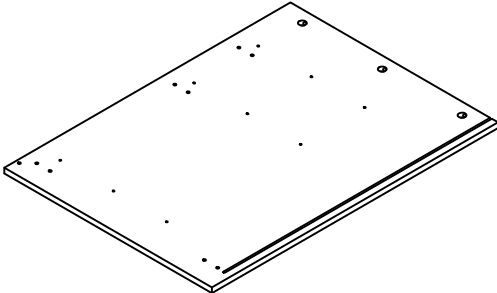
Item no. Nr . N °d article Articolo No. Artículo No	Reference Image Referenzbild Image de référence Immagine di riferimento Imagen de referencia	Qty Menge Qté. Qtà Cant.	Item no. Nr . N °d article Articolo No. Artículo No	Reference Image Referenzbild Image de référence Immagine di riferimento Imagen de referencia	Qty Menge Qté. Qtà Cant.
17		X2	21		X1
18		X2	22		X1
19		X1	23		X1
20		X2	24		X1

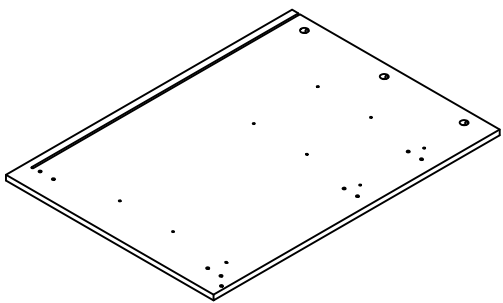
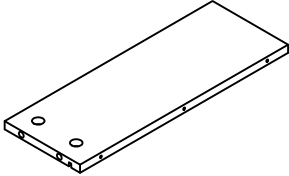
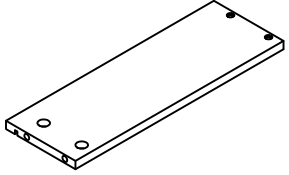
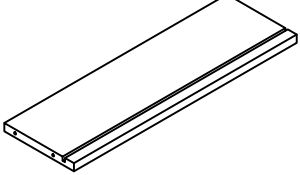
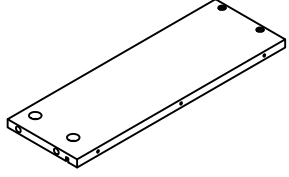
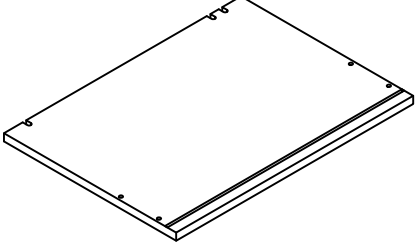
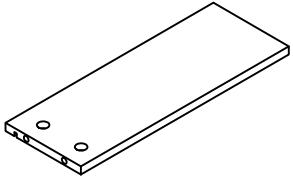
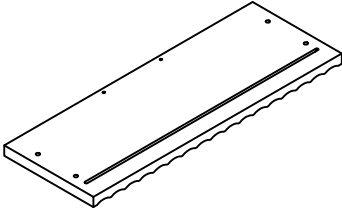
Item no. Nr . N °d article Articolo No. Artículo No	Reference Image Referenzbild Image de référence Immagine di riferimento Imagen de referencia	Qty Menge Qté. Qtà Cant.	Item no. Nr . N °d article Articolo No. Artículo No	Reference Image Referenzbild Image de référence Immagine di riferimento Imagen de referencia	Qty Menge Qté. Qtà Cant.
25		X1	29		X1
26		X2	30		X2
27		X2	31		X1
28		X1	32		X2

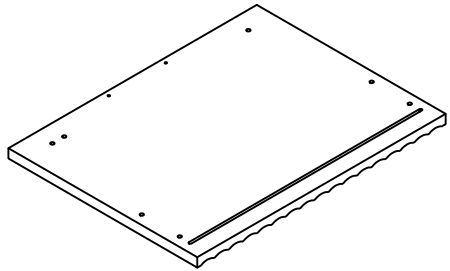
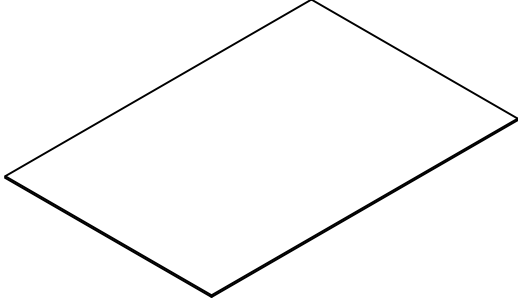
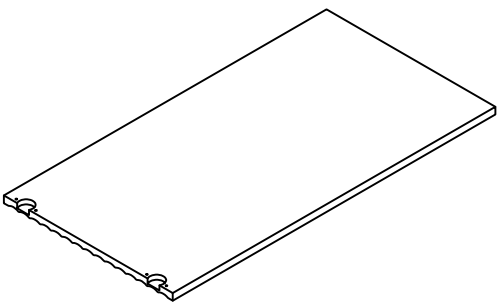
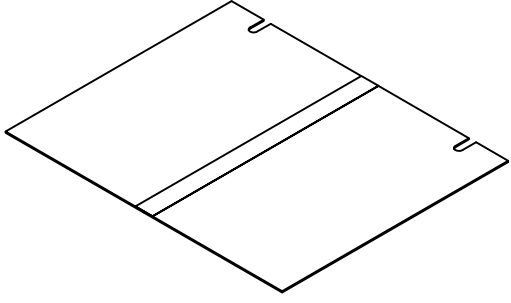
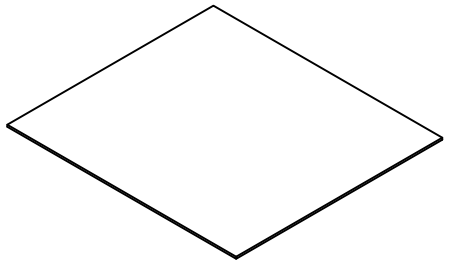
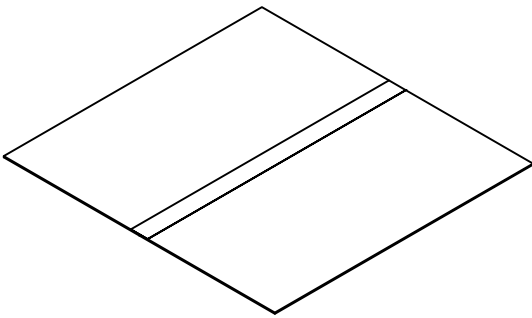
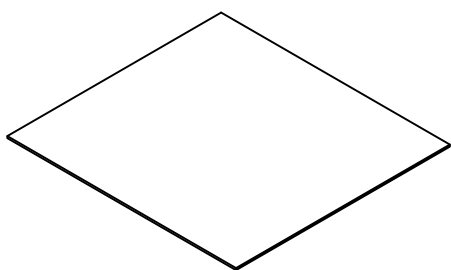
Item no. Nr . N °d article Articolo No. Artículo No	Reference Image Referenzbild Image de référence Immagine di riferimento Imagen de referencia	Qty Menge Qté. Qtà Cant.	Item no. Nr . N °d article Articolo No. Artículo No	Reference Image Referenzbild Image de référence Immagine di riferimento Imagen de referencia	Qty Menge Qté. Qtà Cant.
33		X1	37		X1
34		X1	38		X1
35		X2	39		X1
36		X1			

EXPLODED VIEW

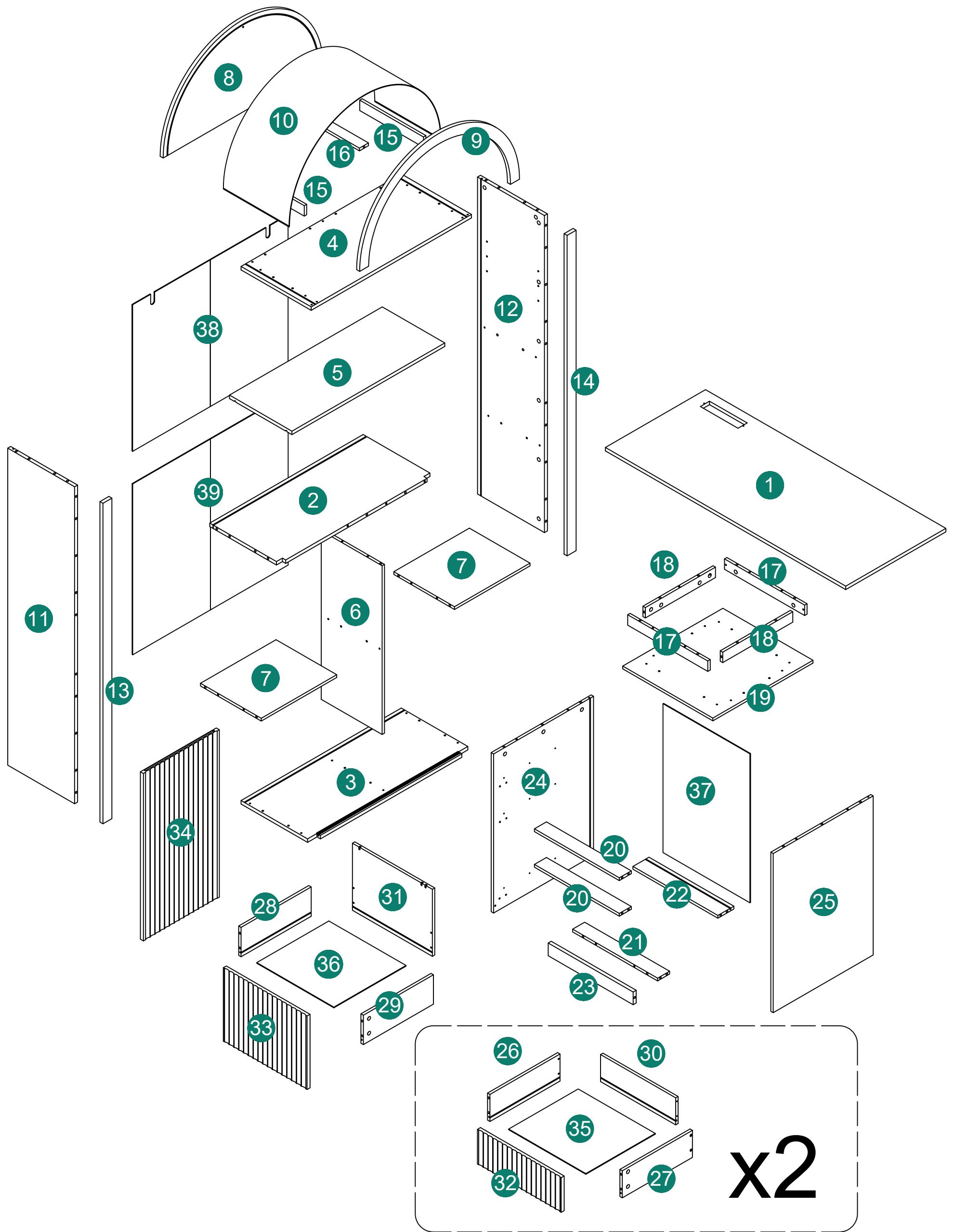

1

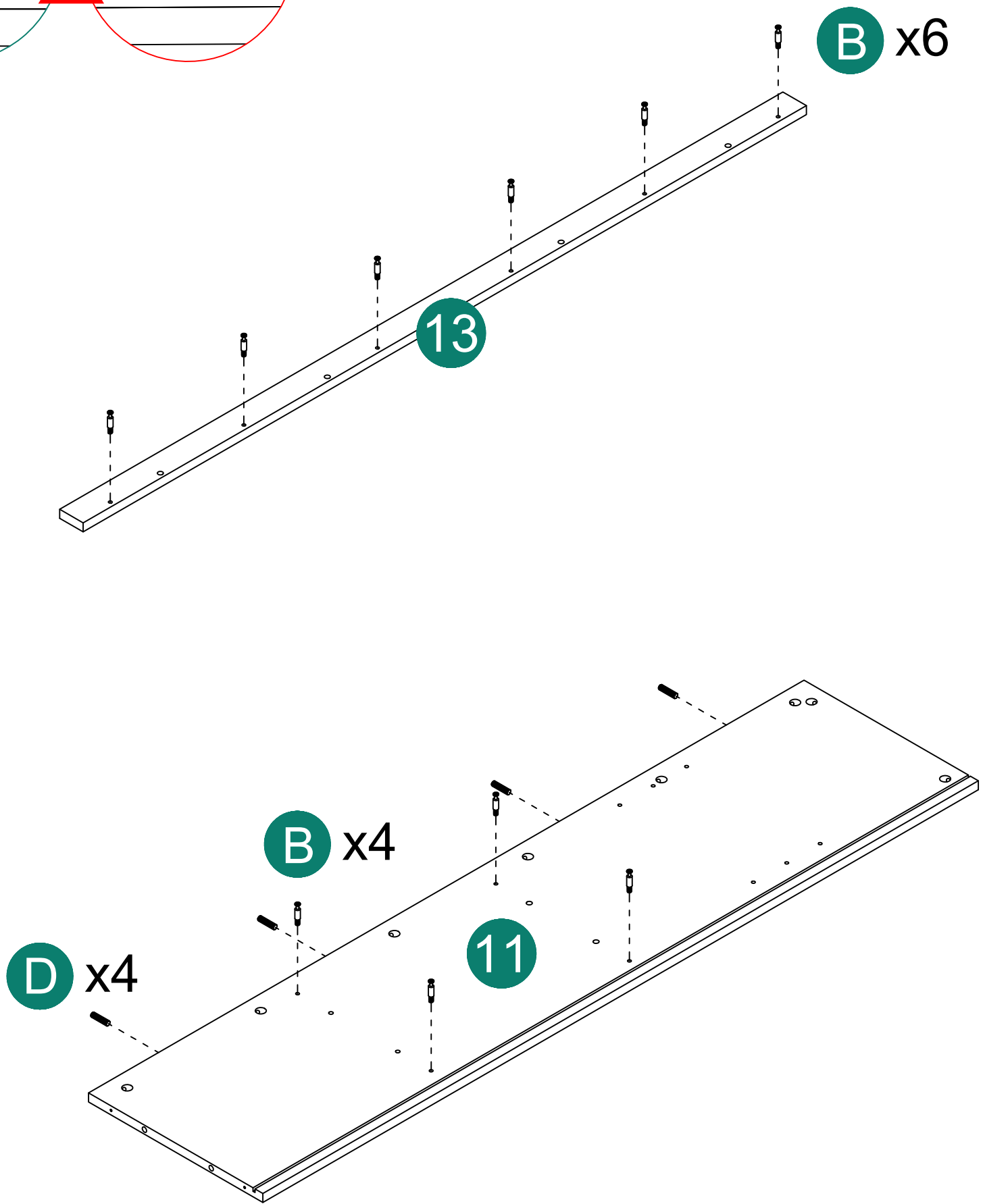
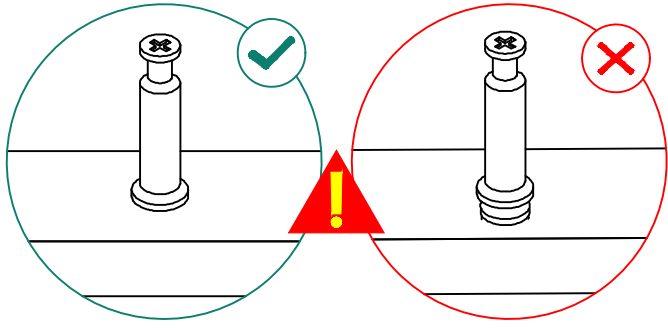
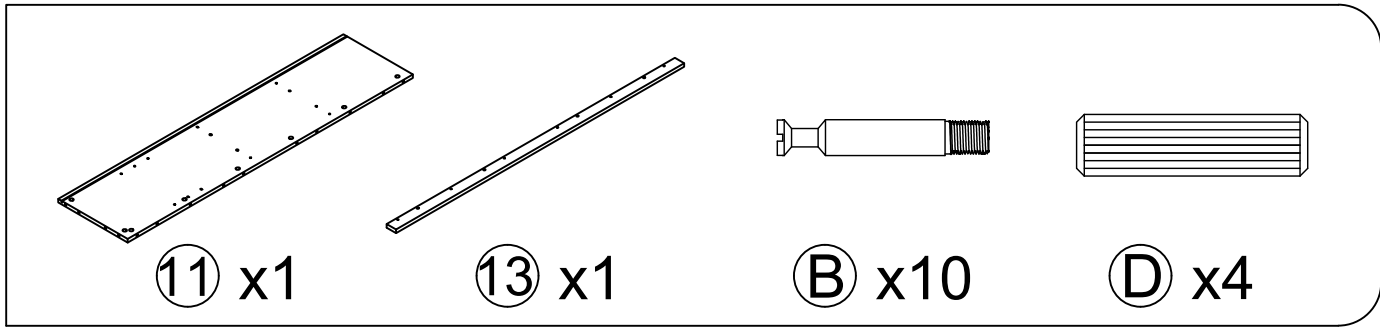

2

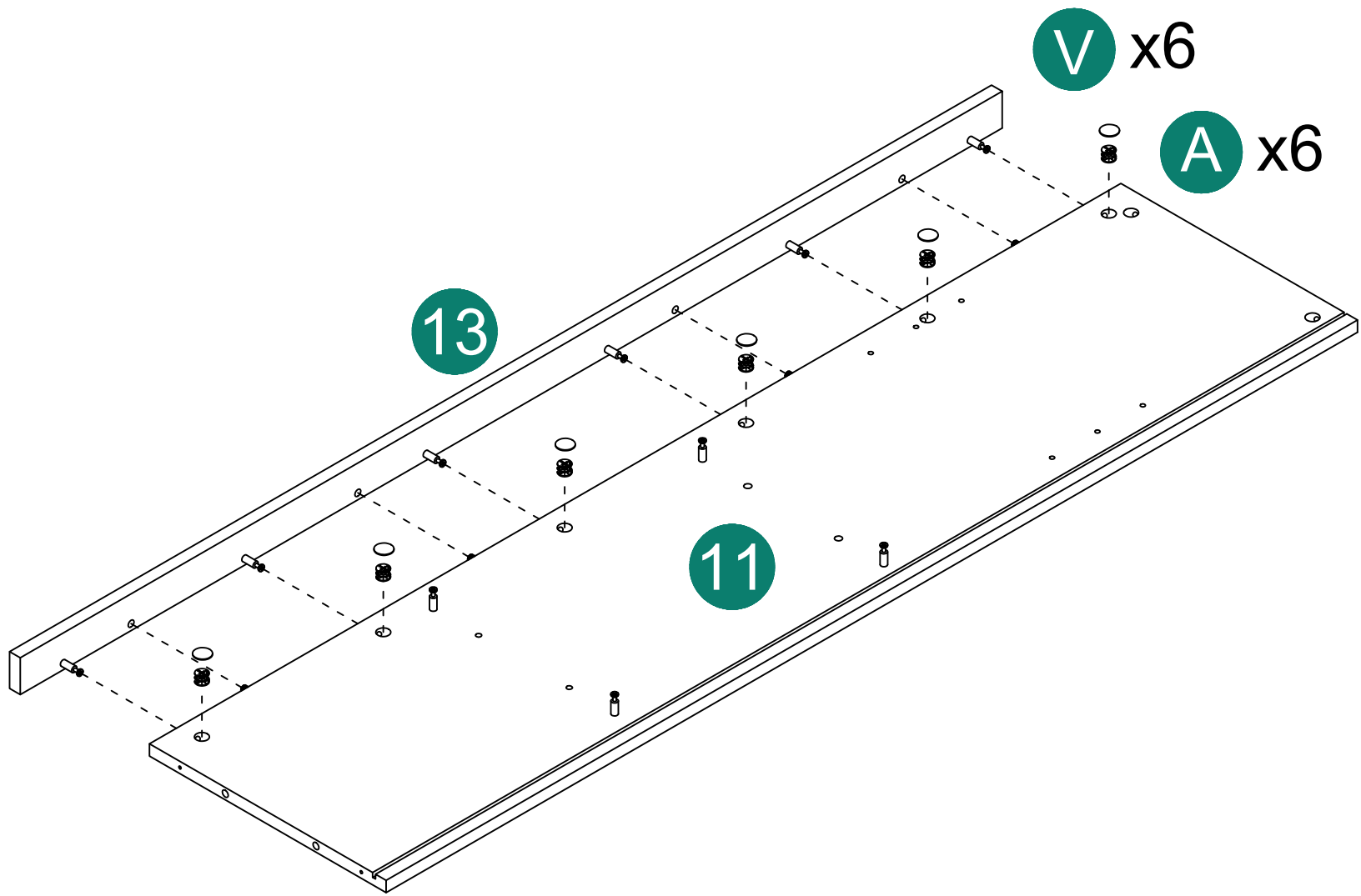
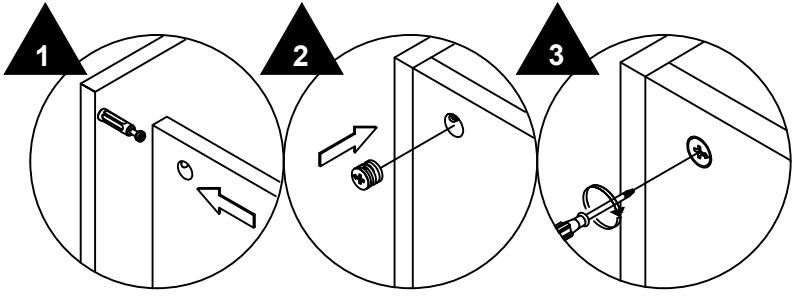
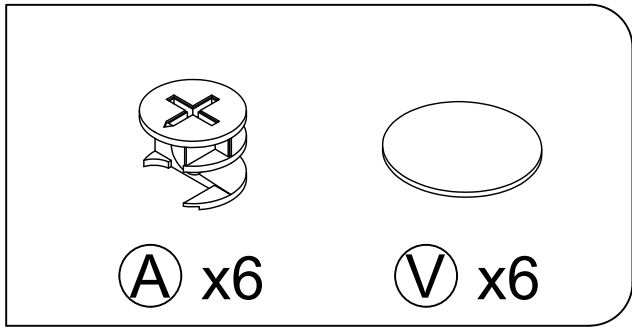

3

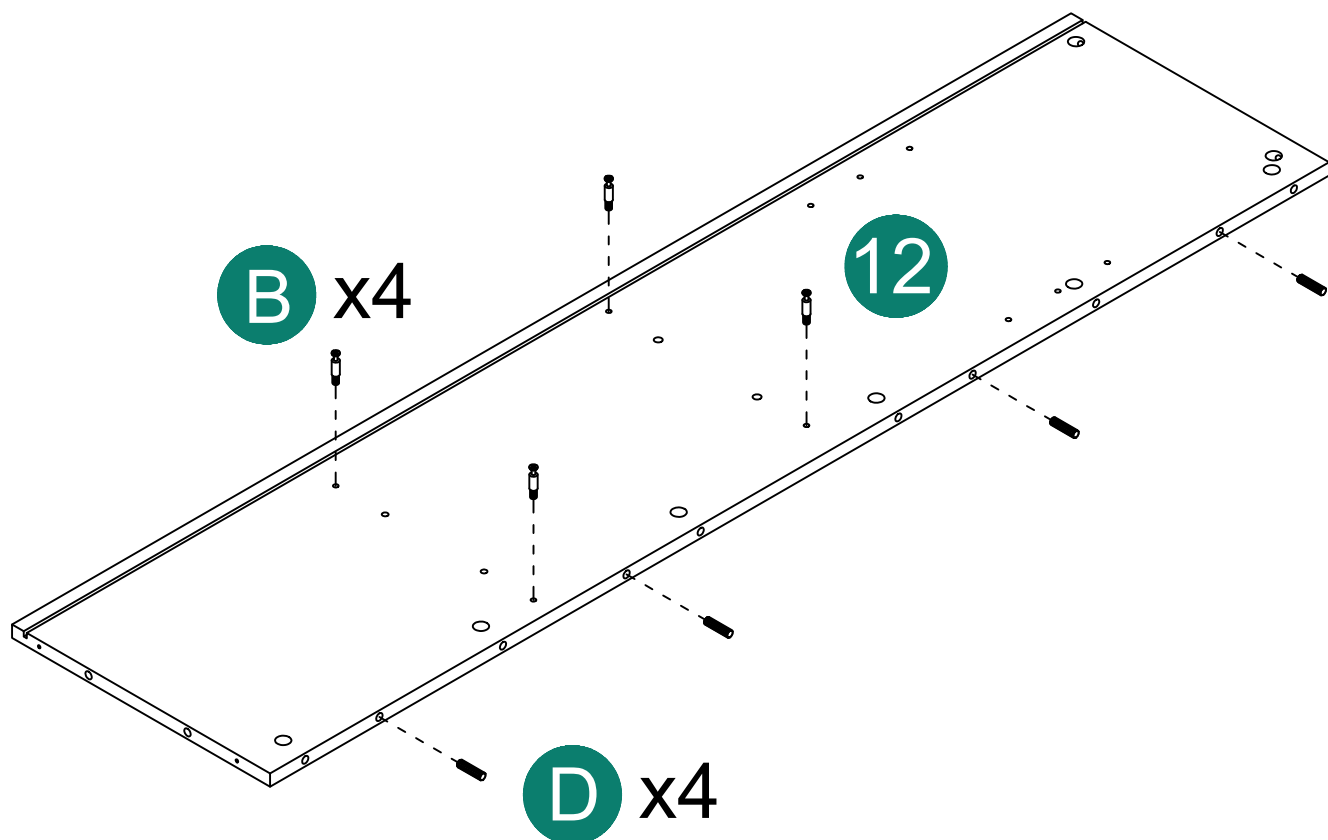
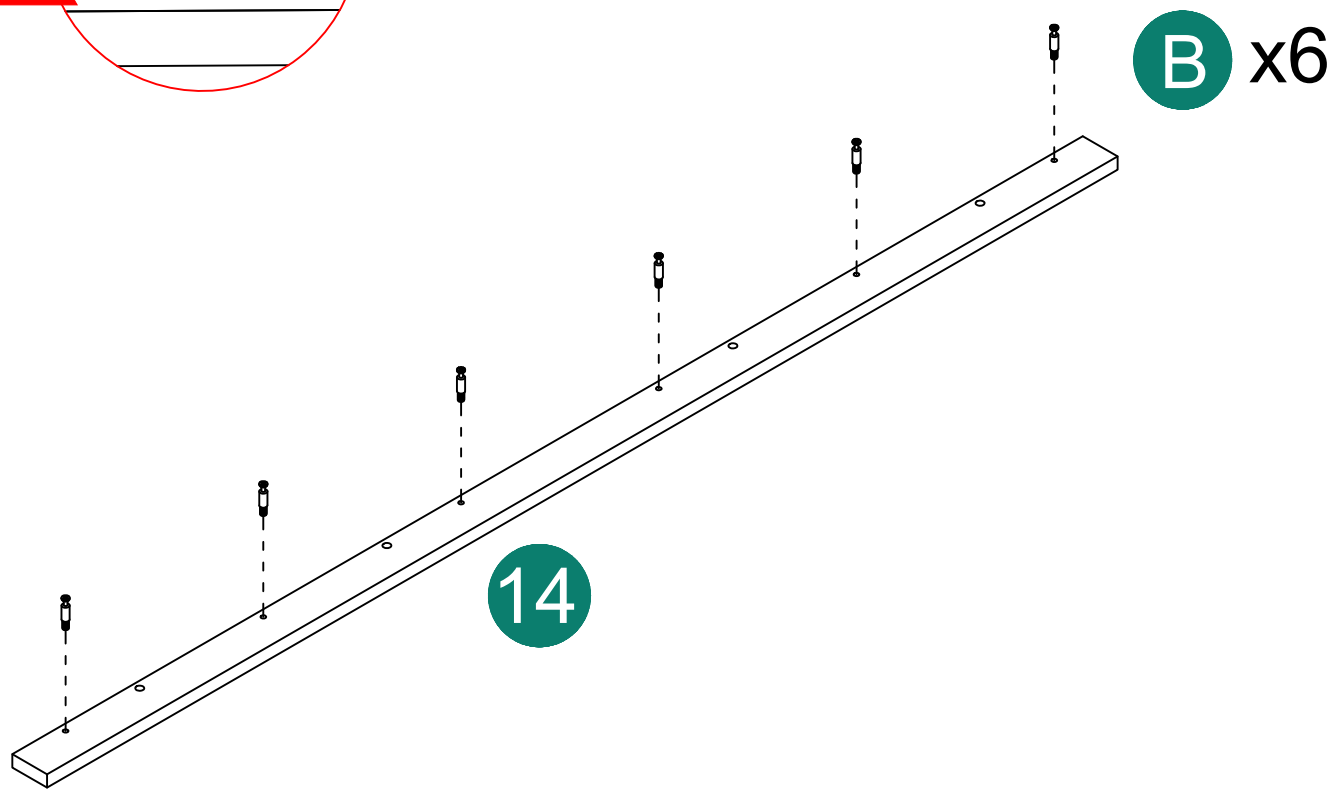
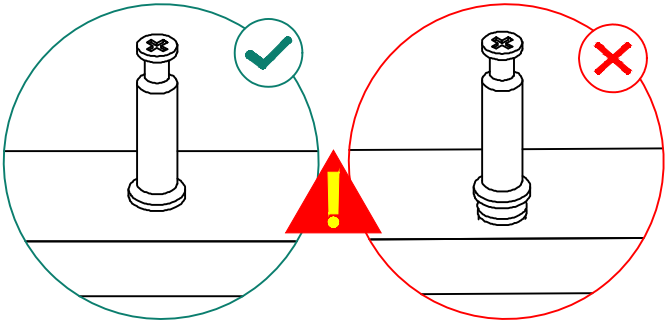
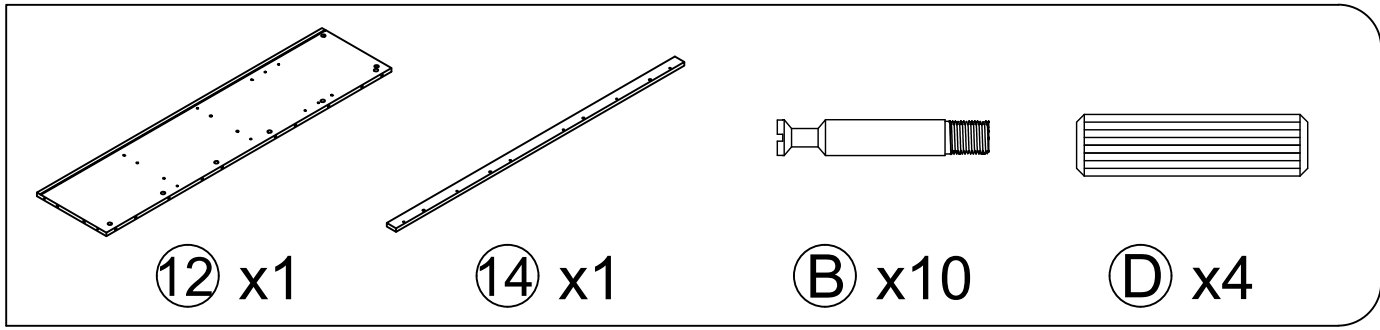

4

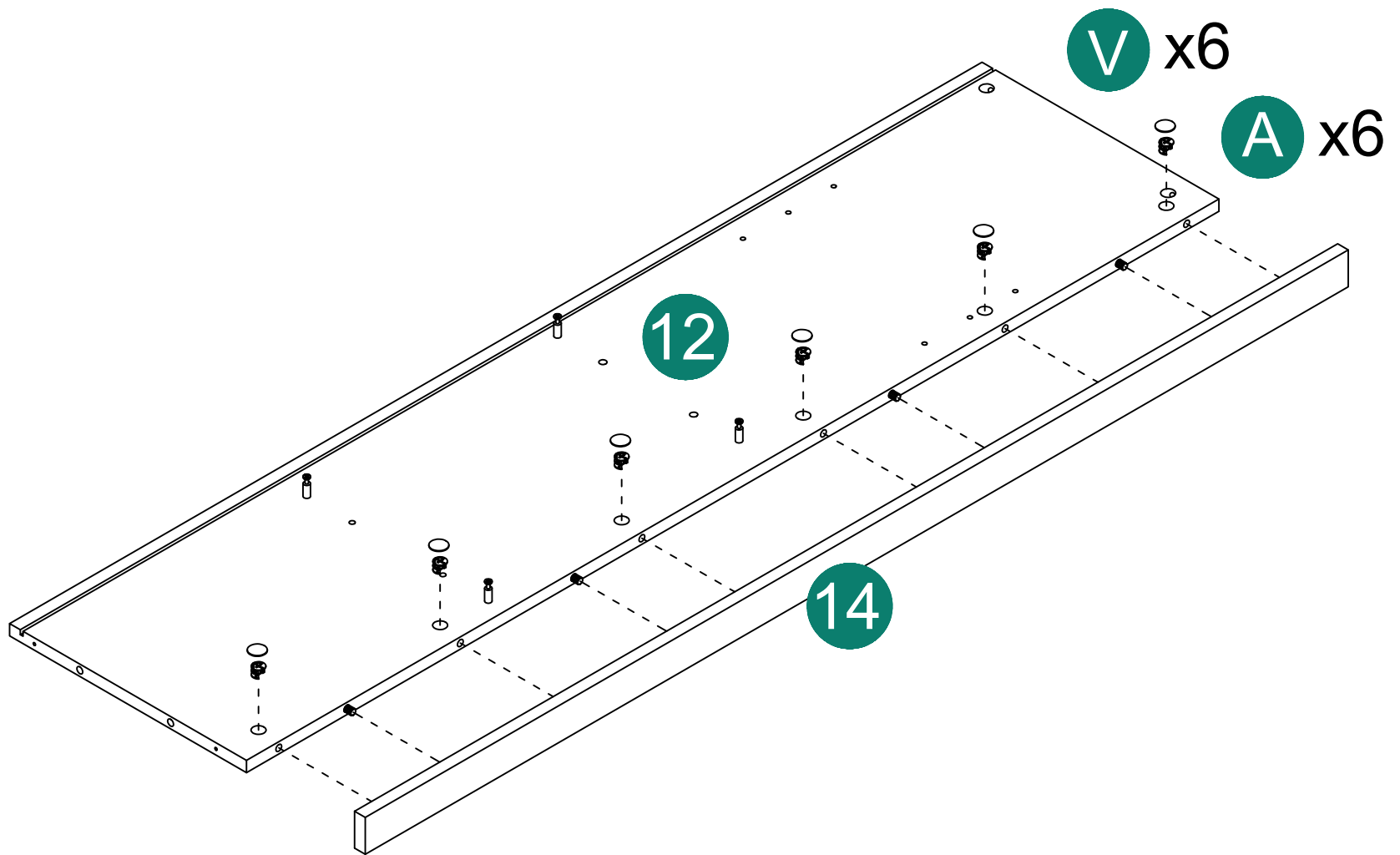
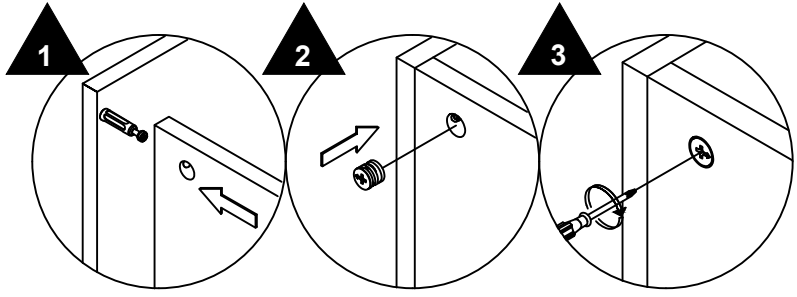
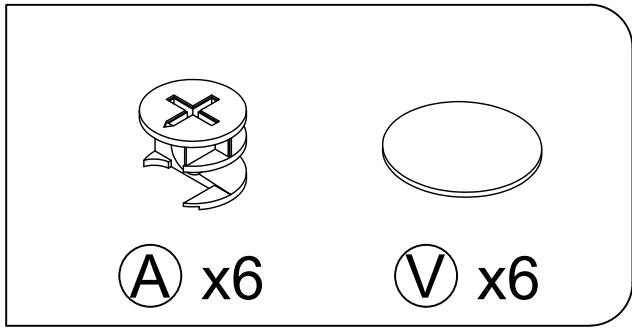

5

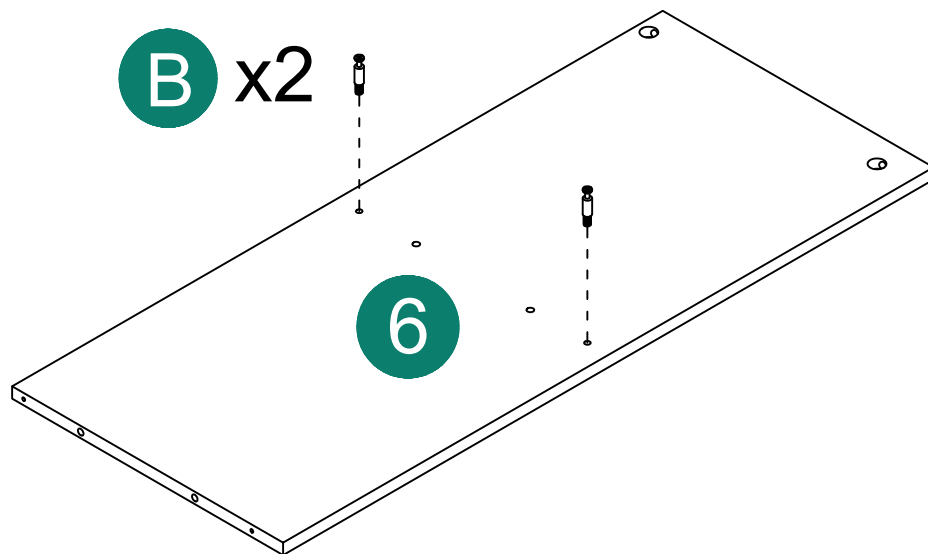
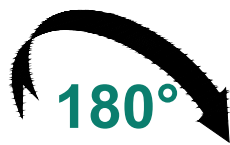
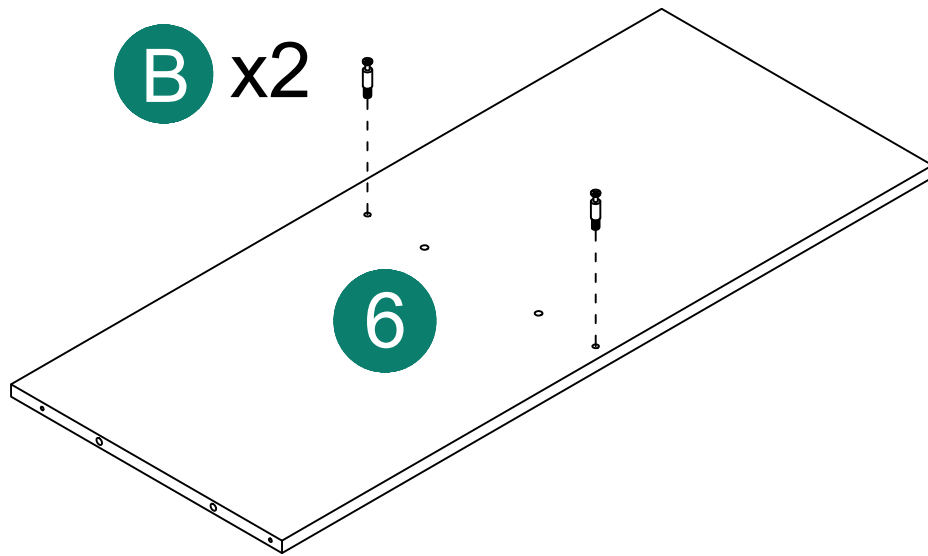
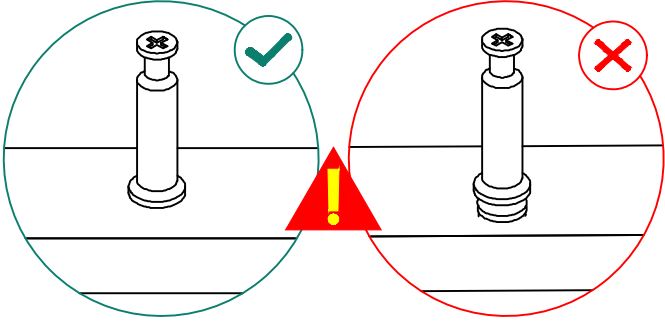
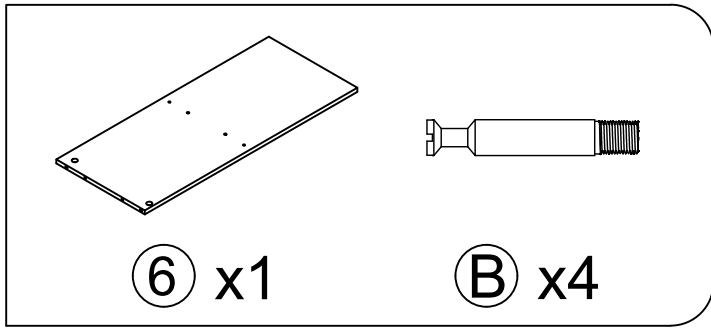

6

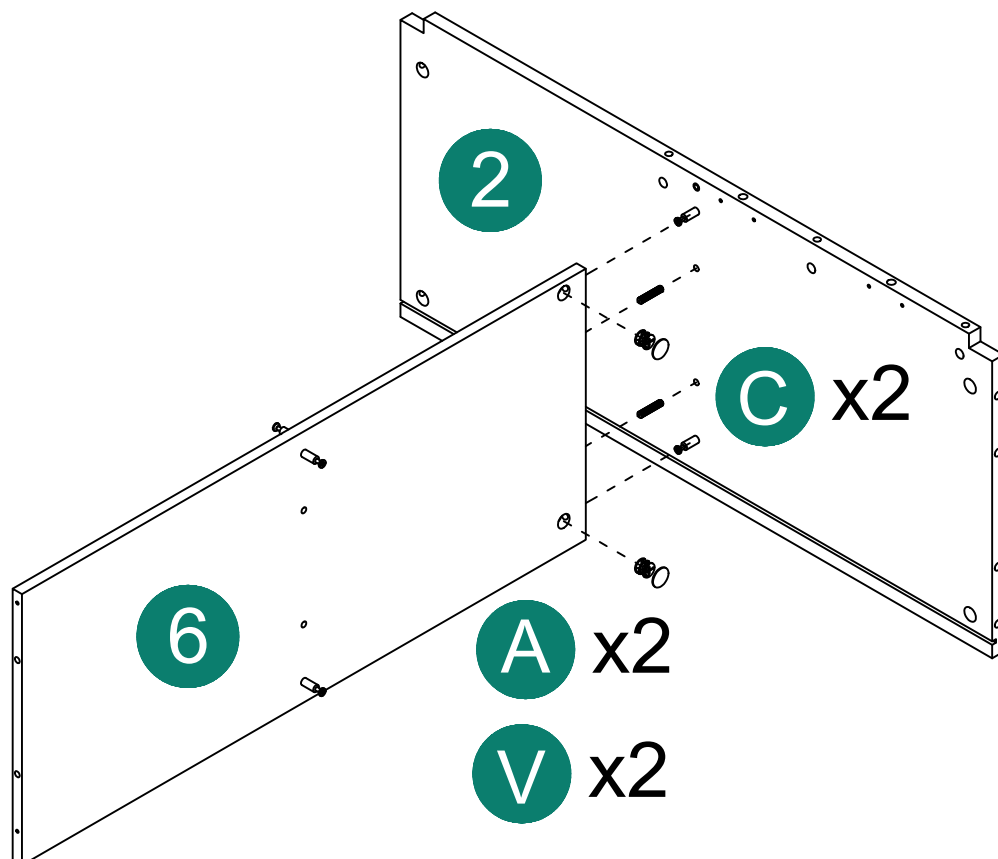
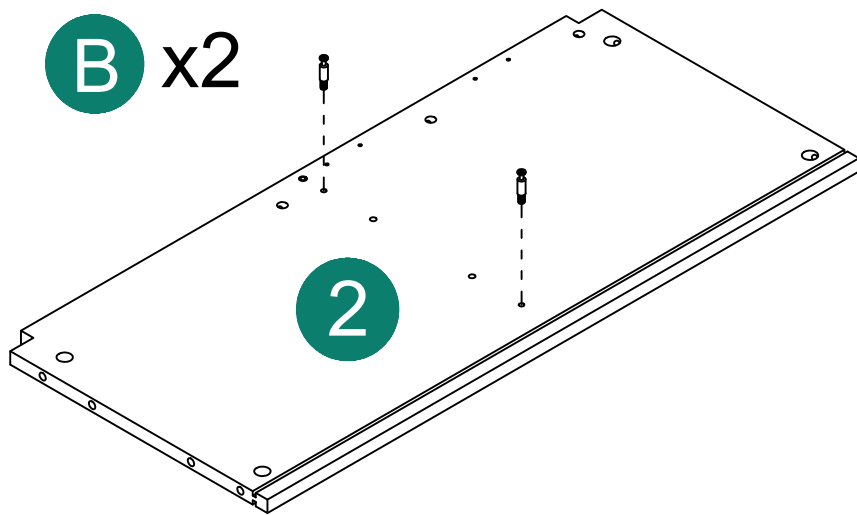
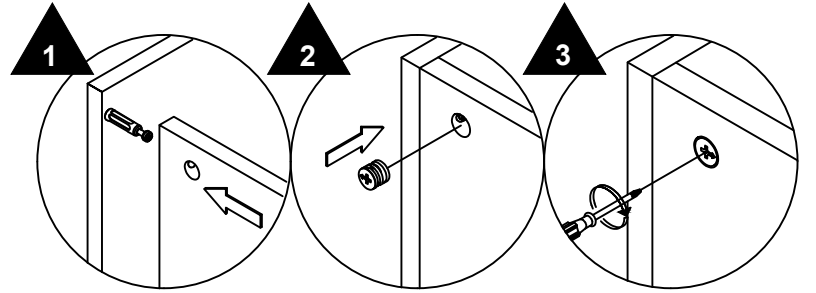
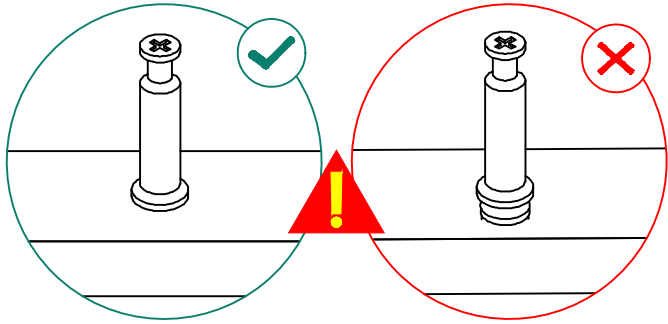
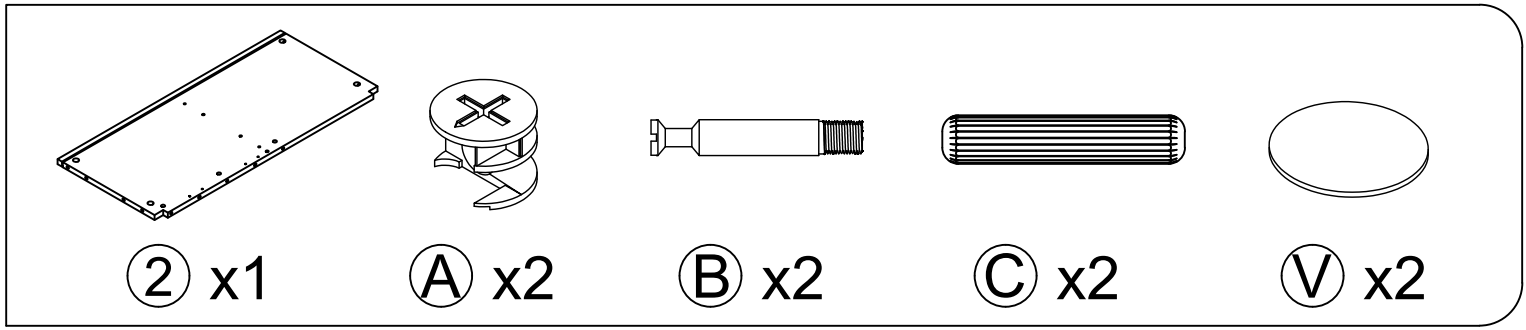

7

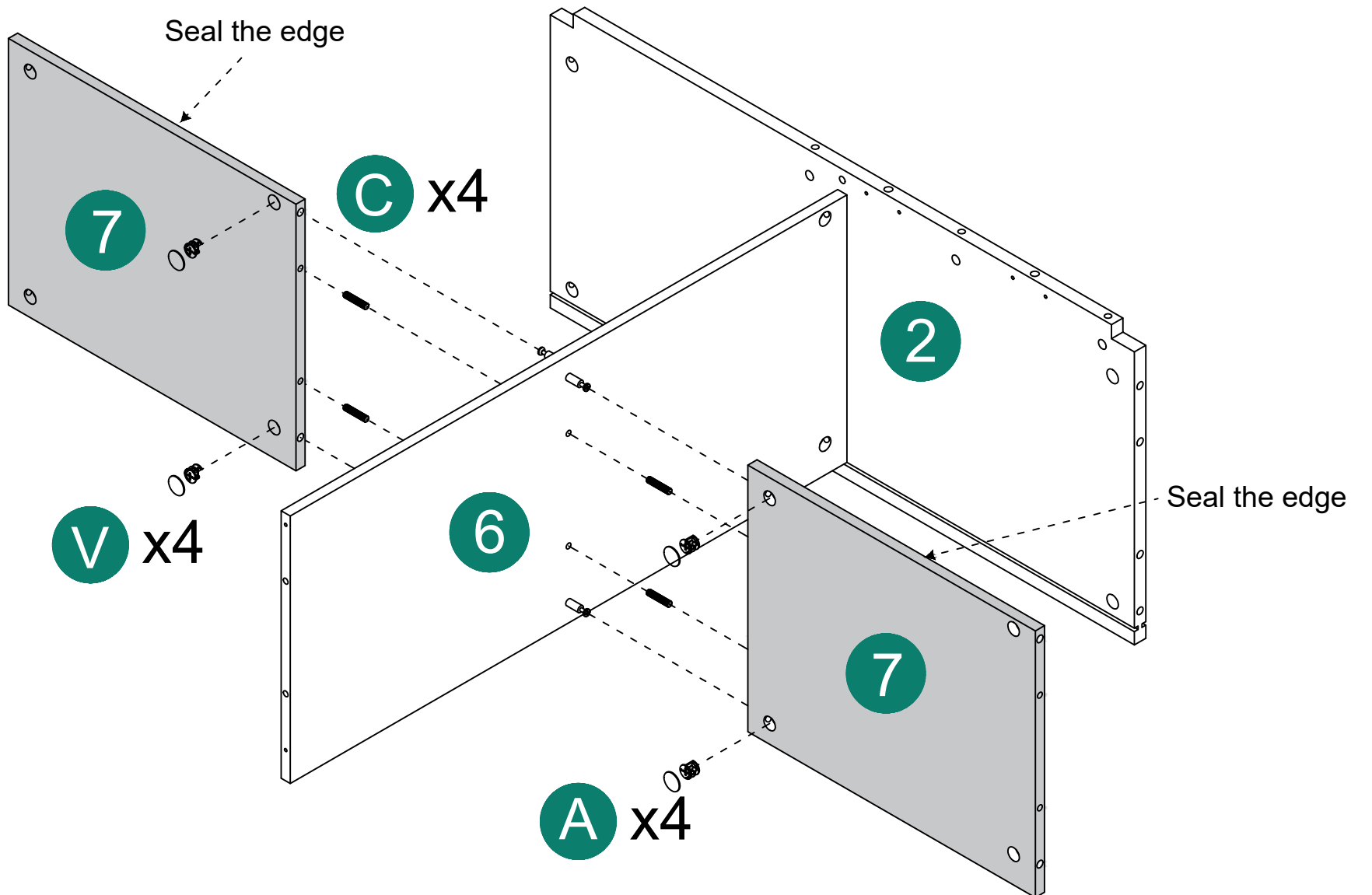
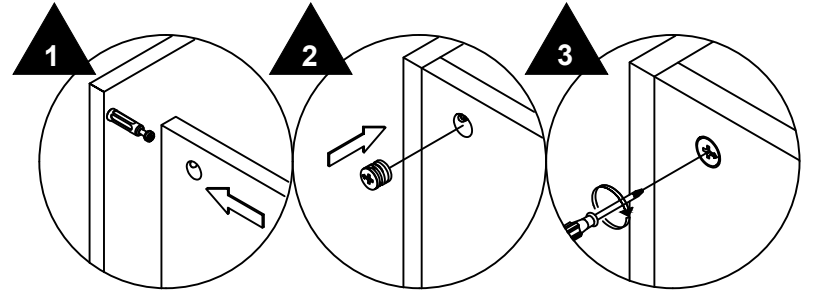
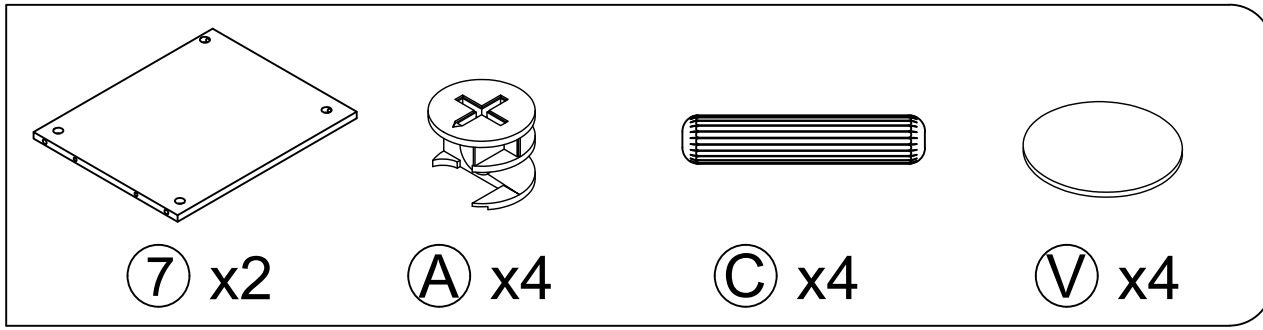

8

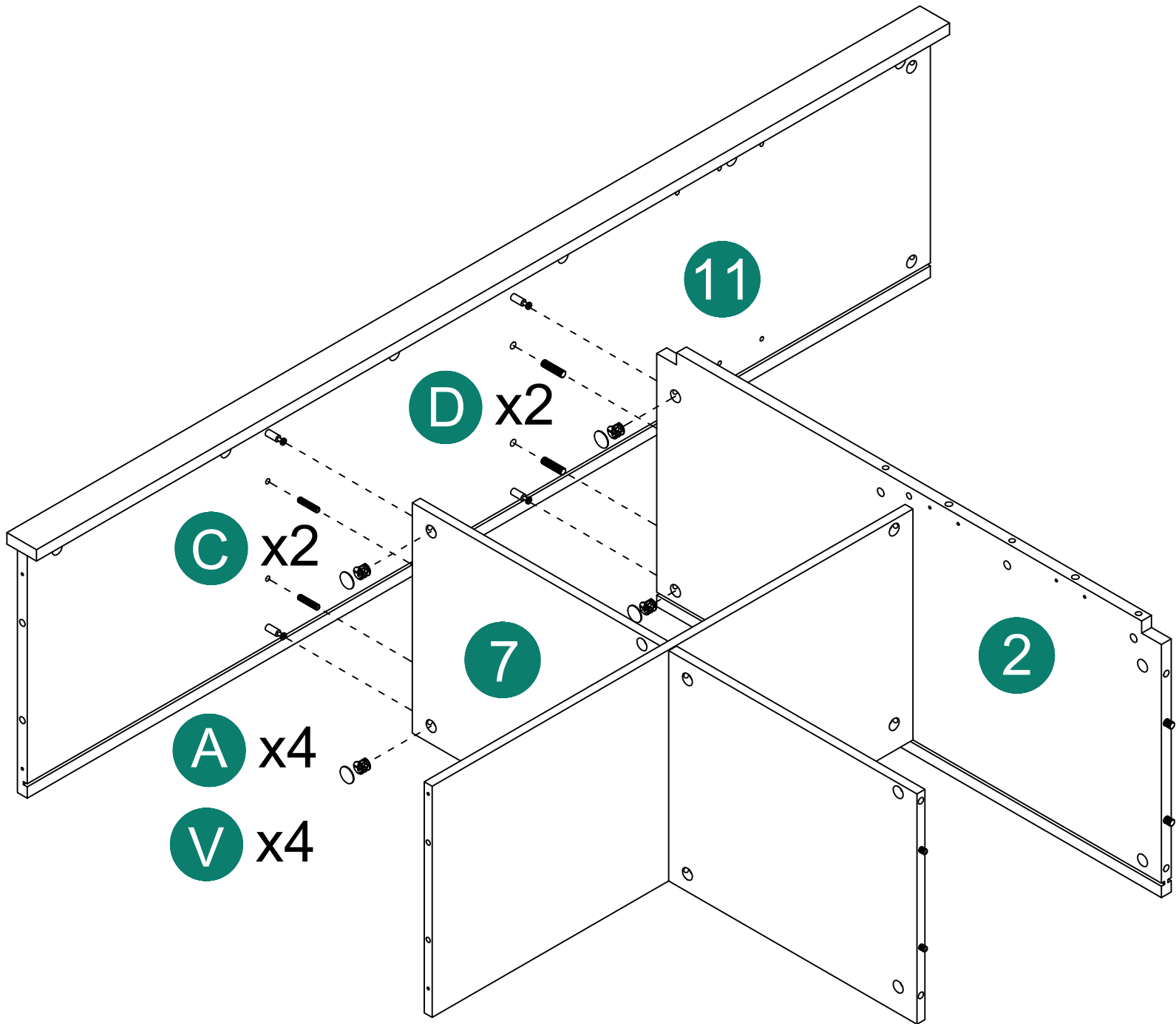
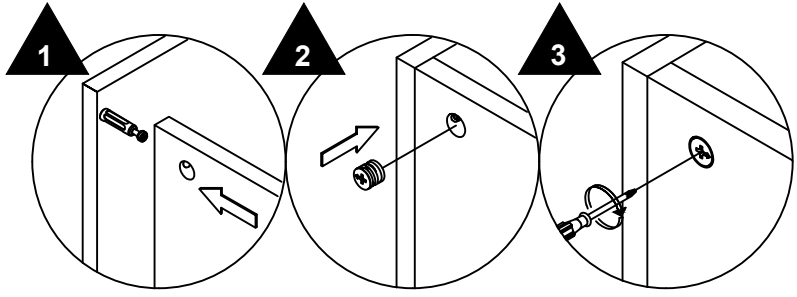
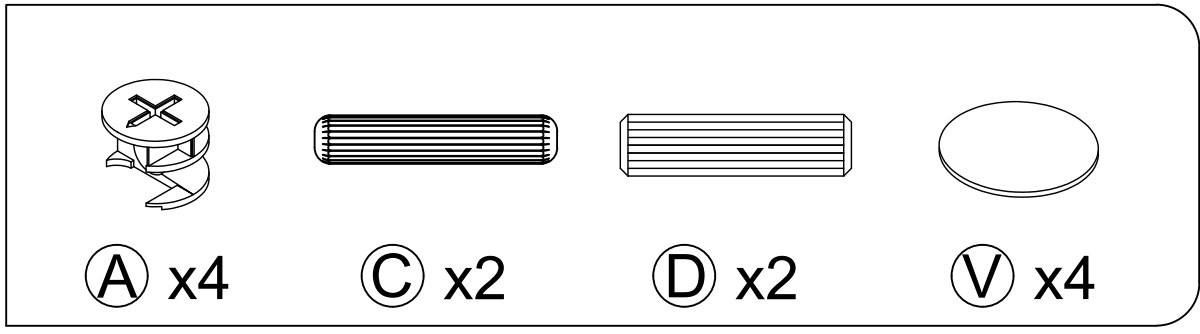

9

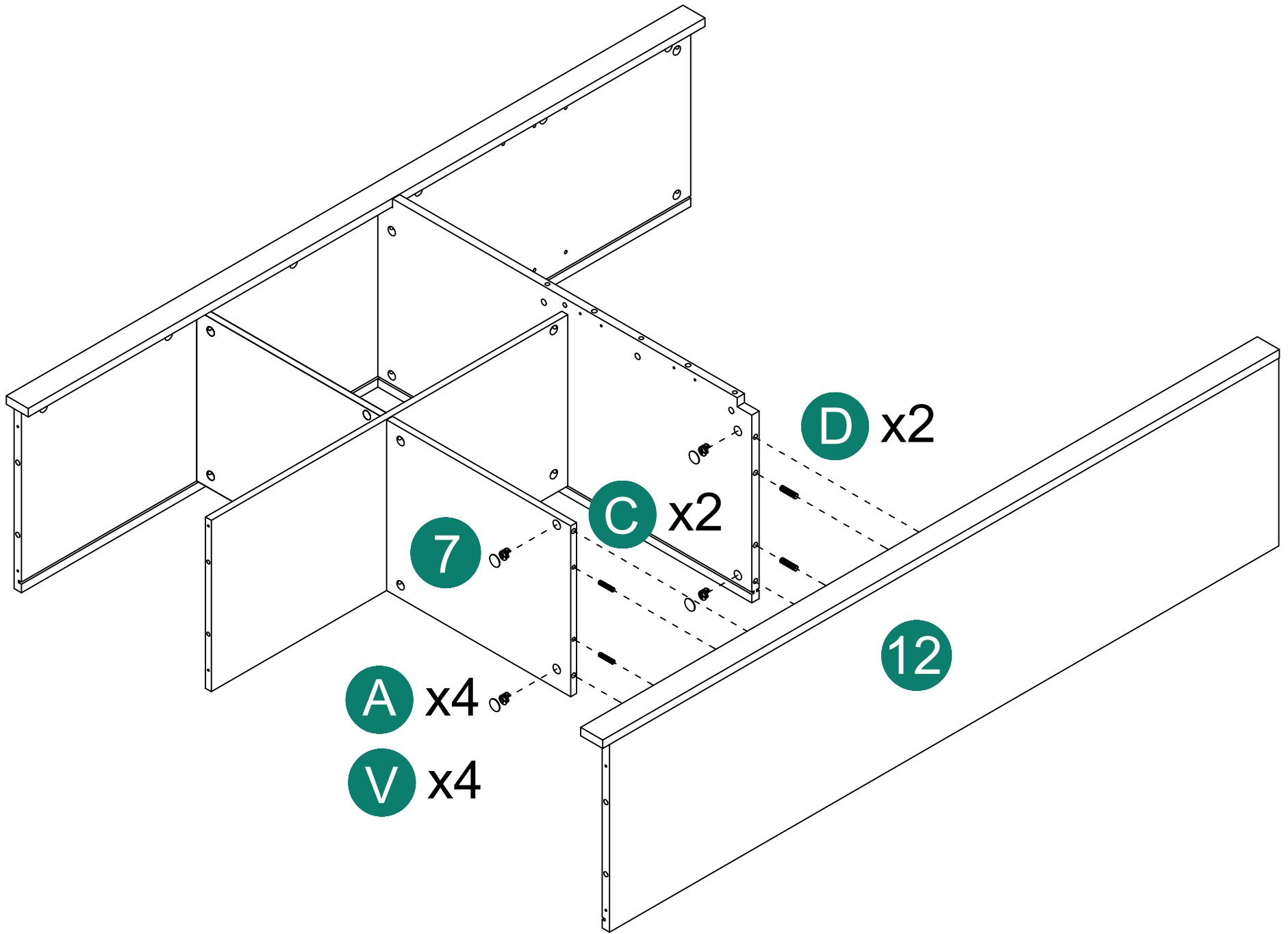
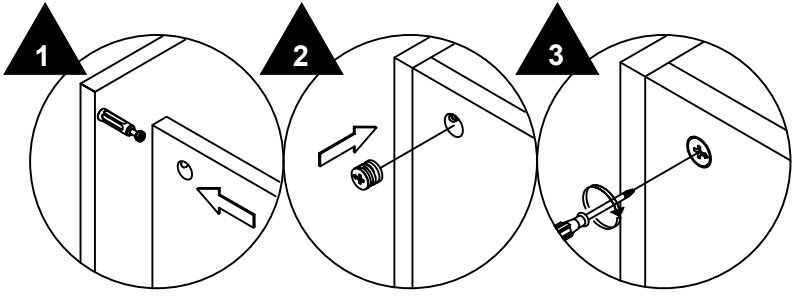
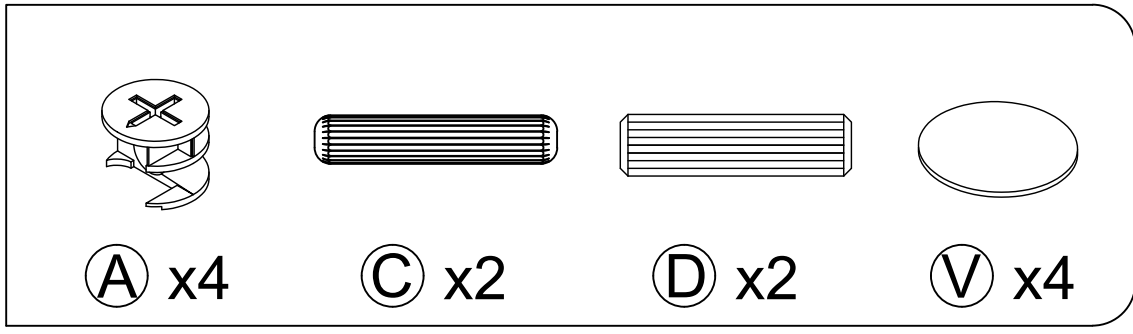

10

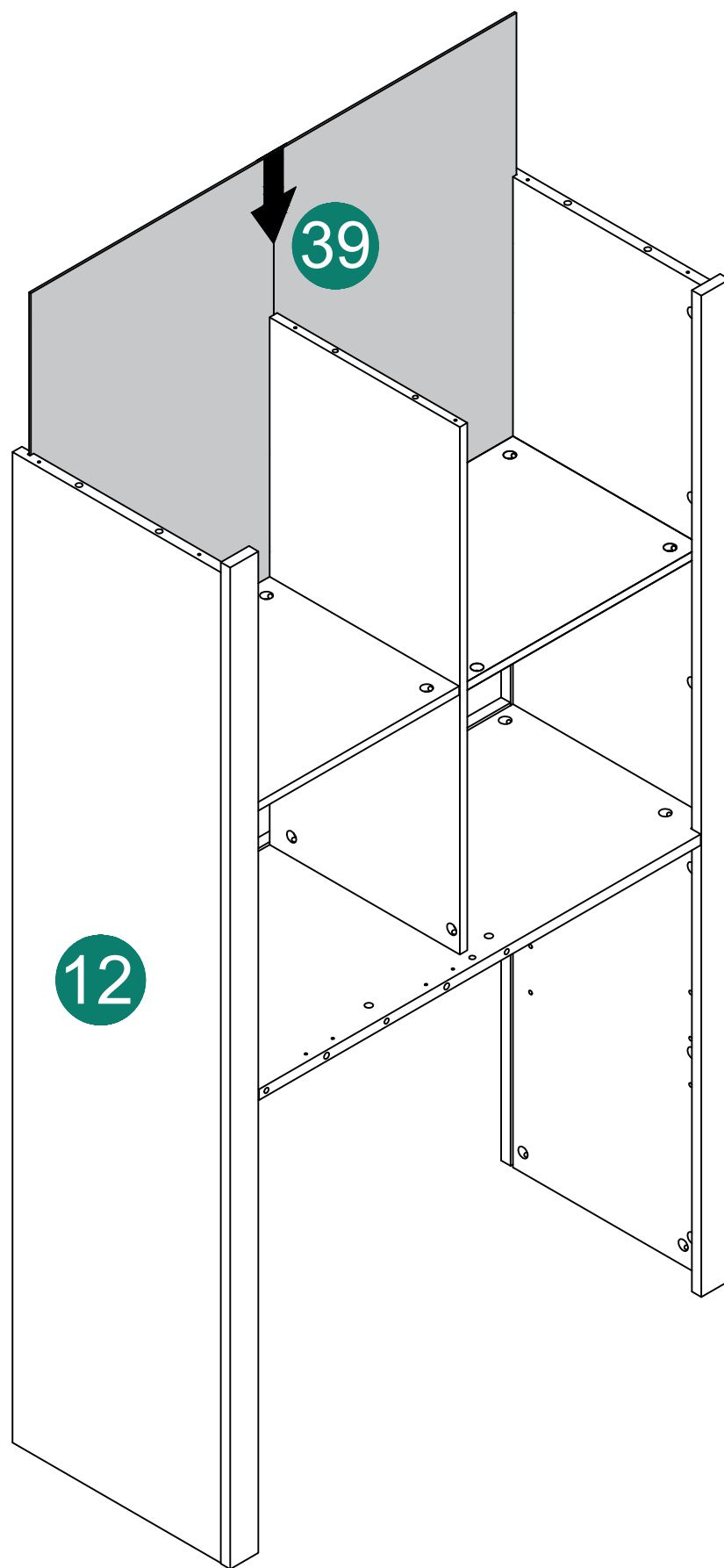
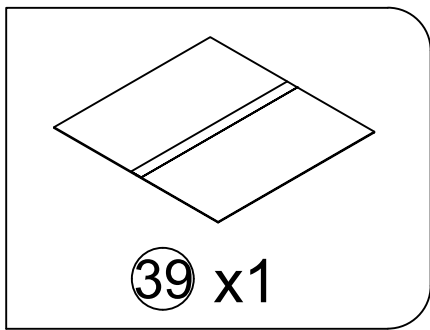

11

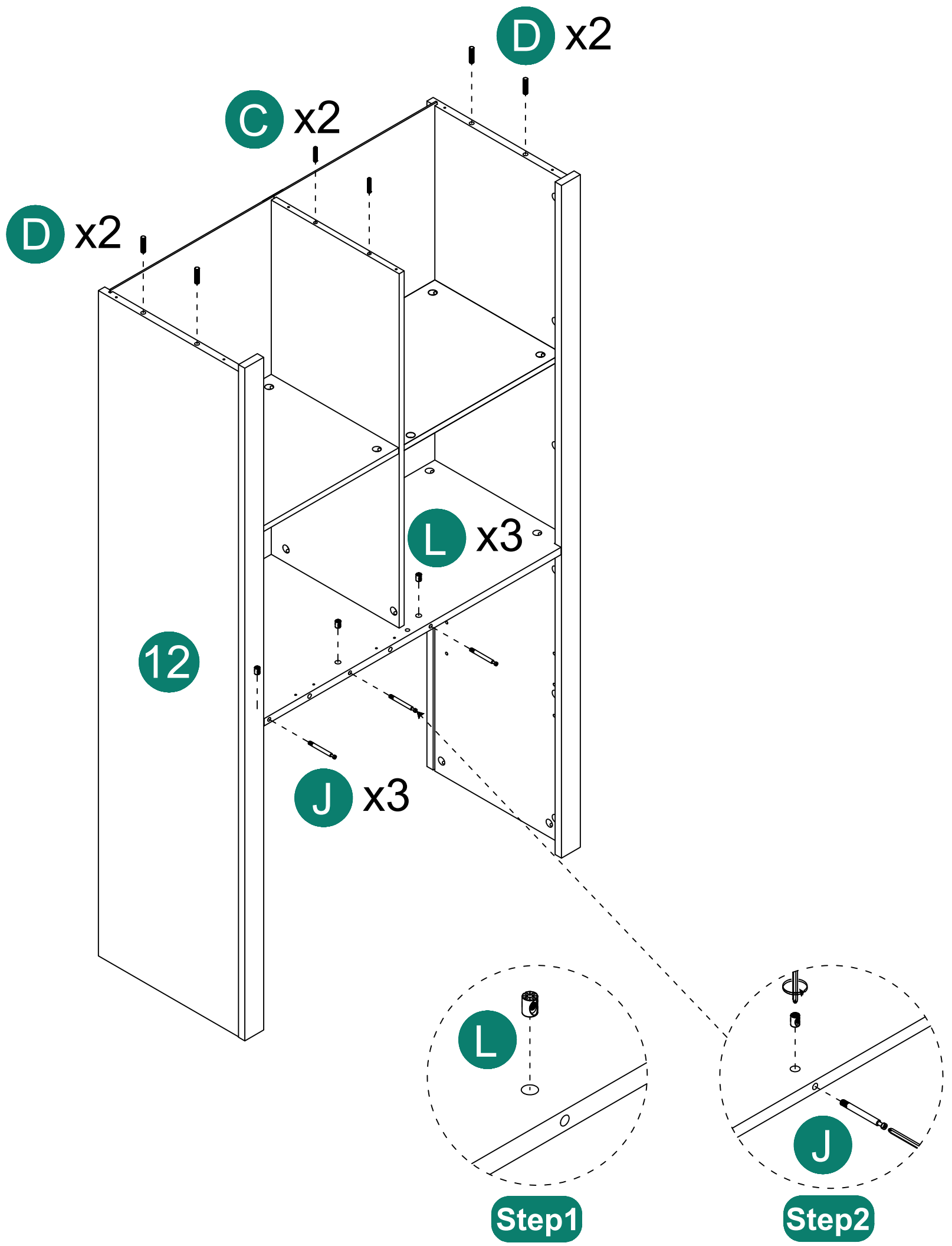
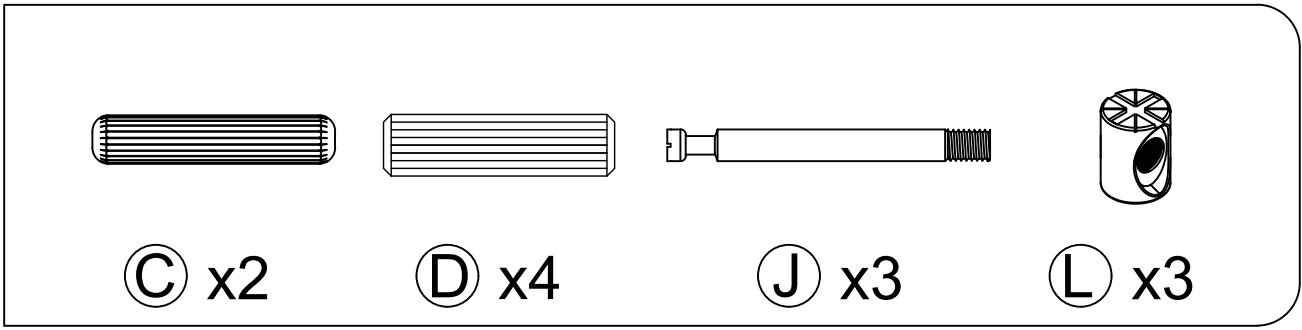

12

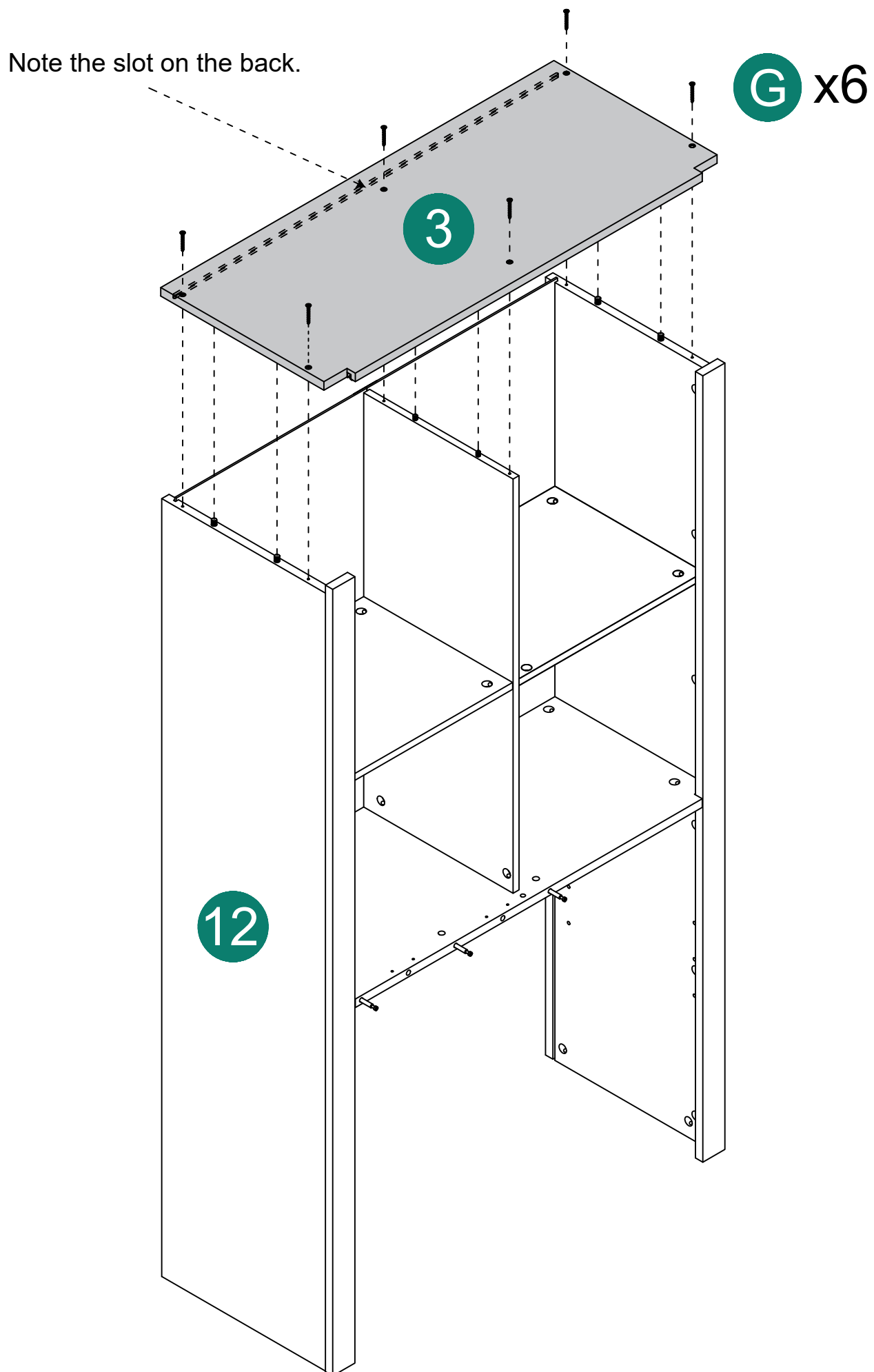
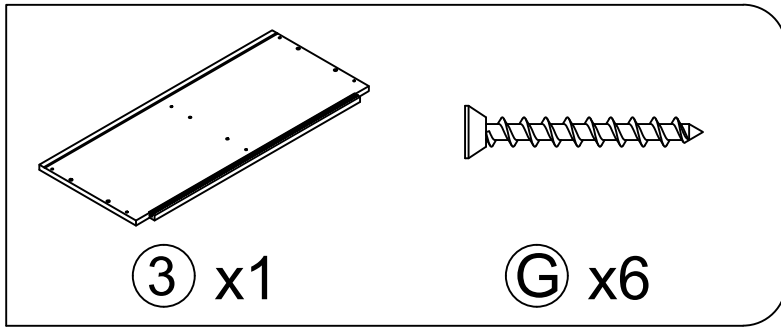

13

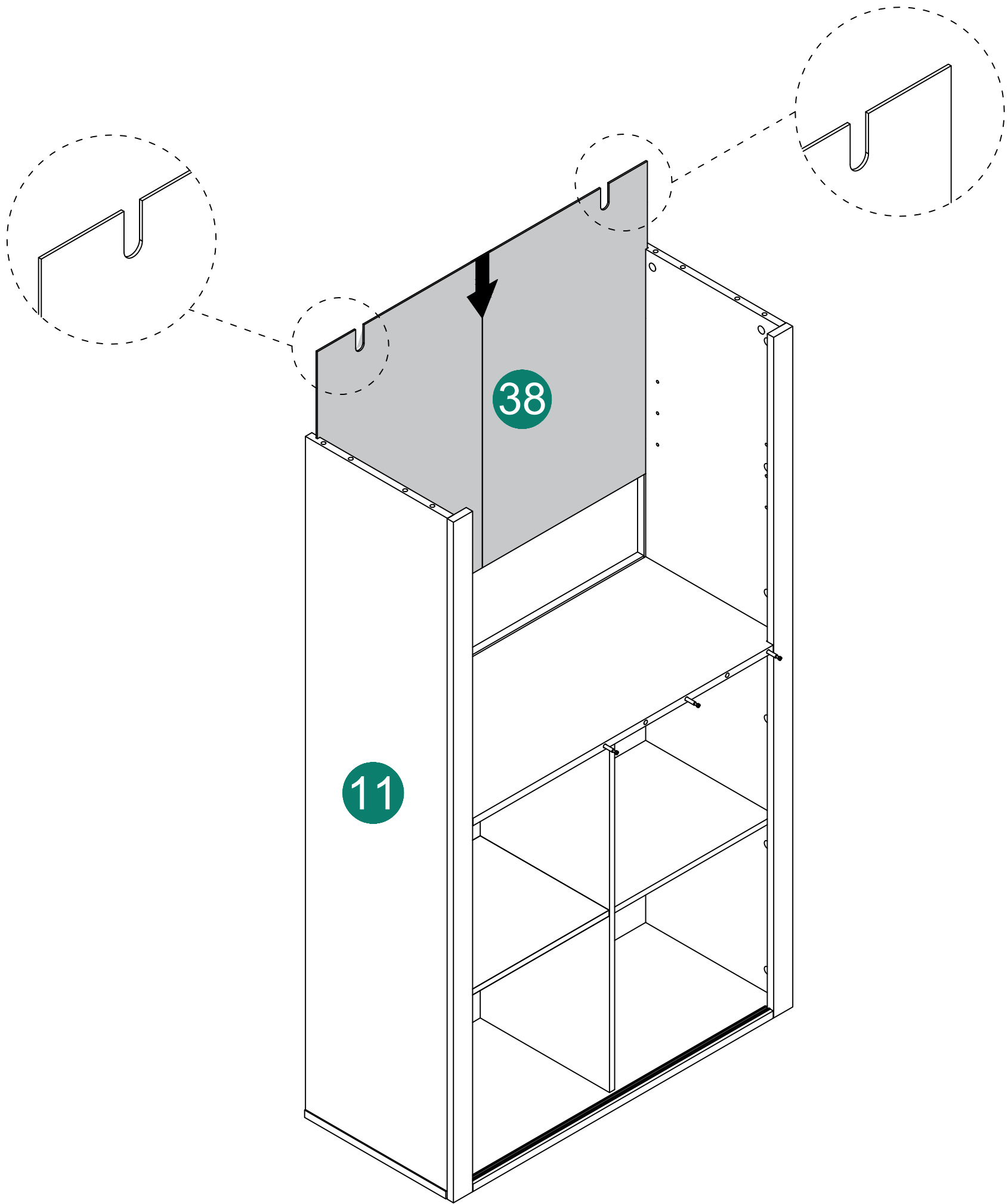
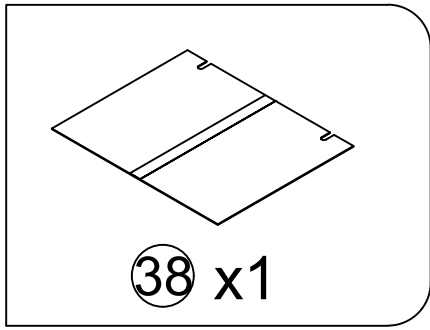

14

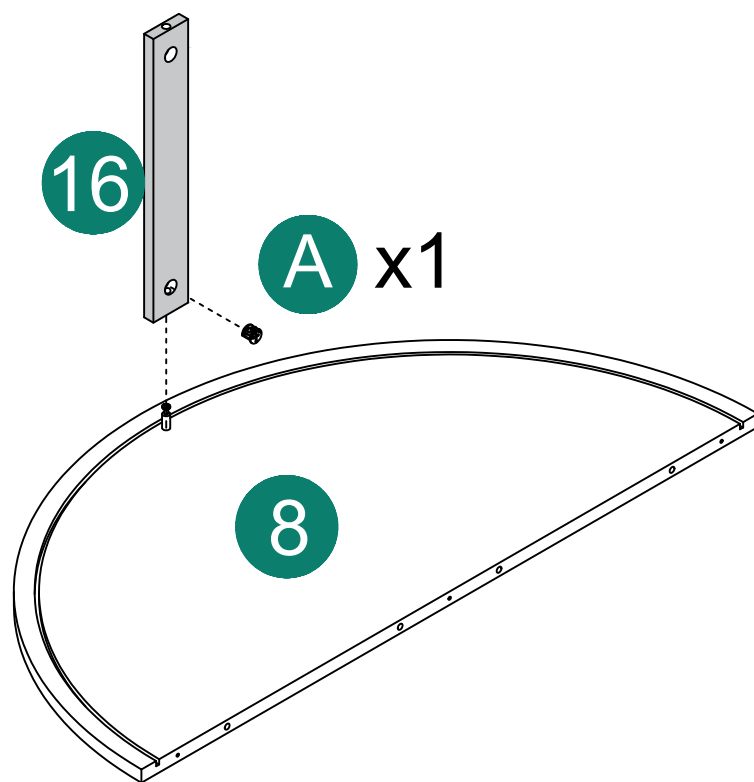
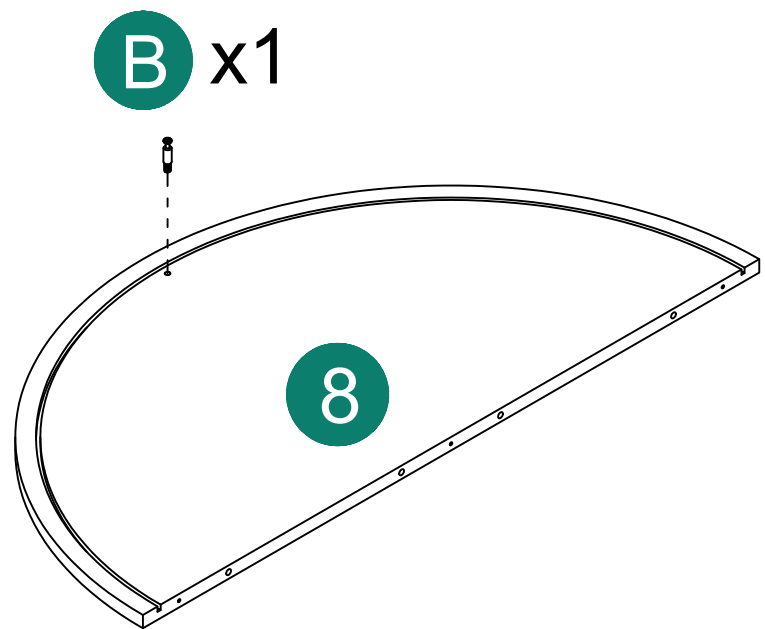
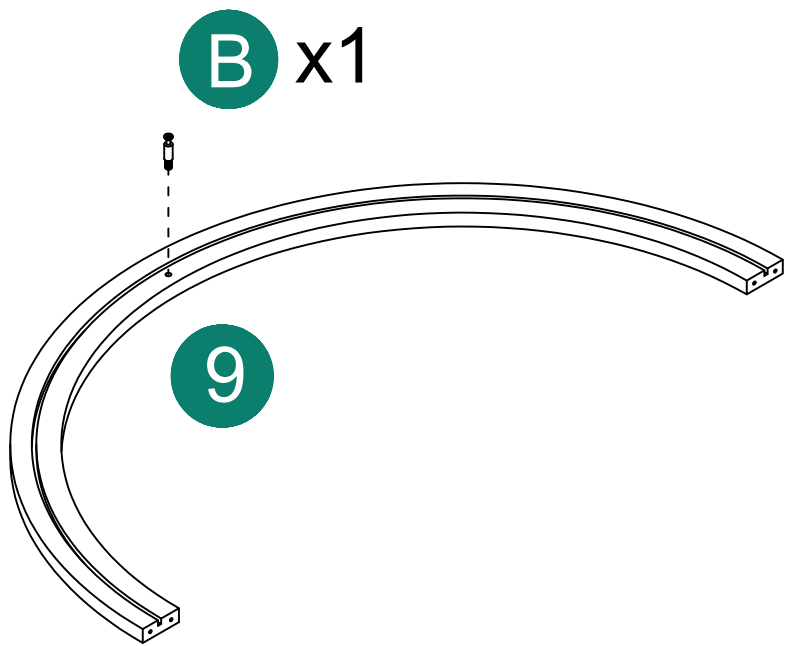
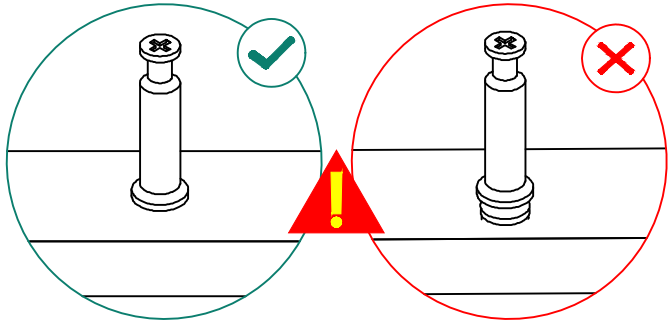
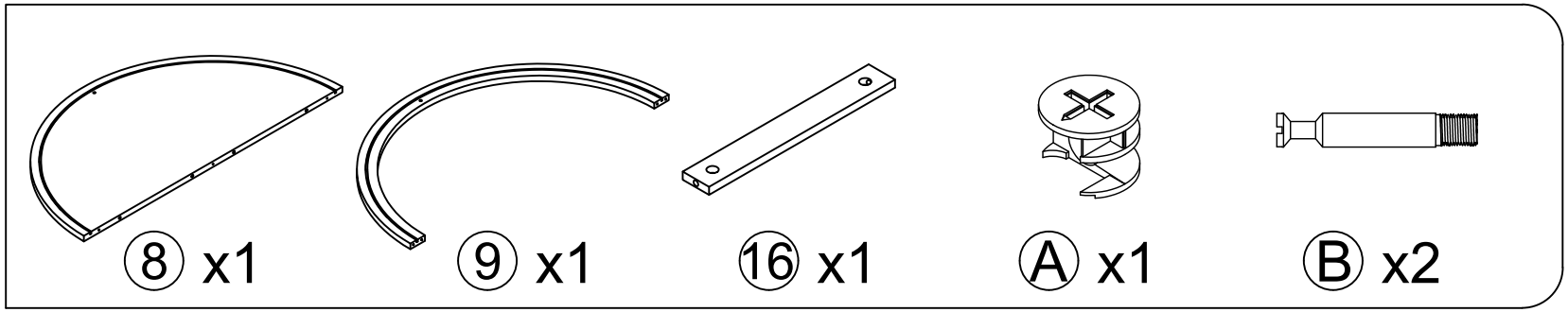

15

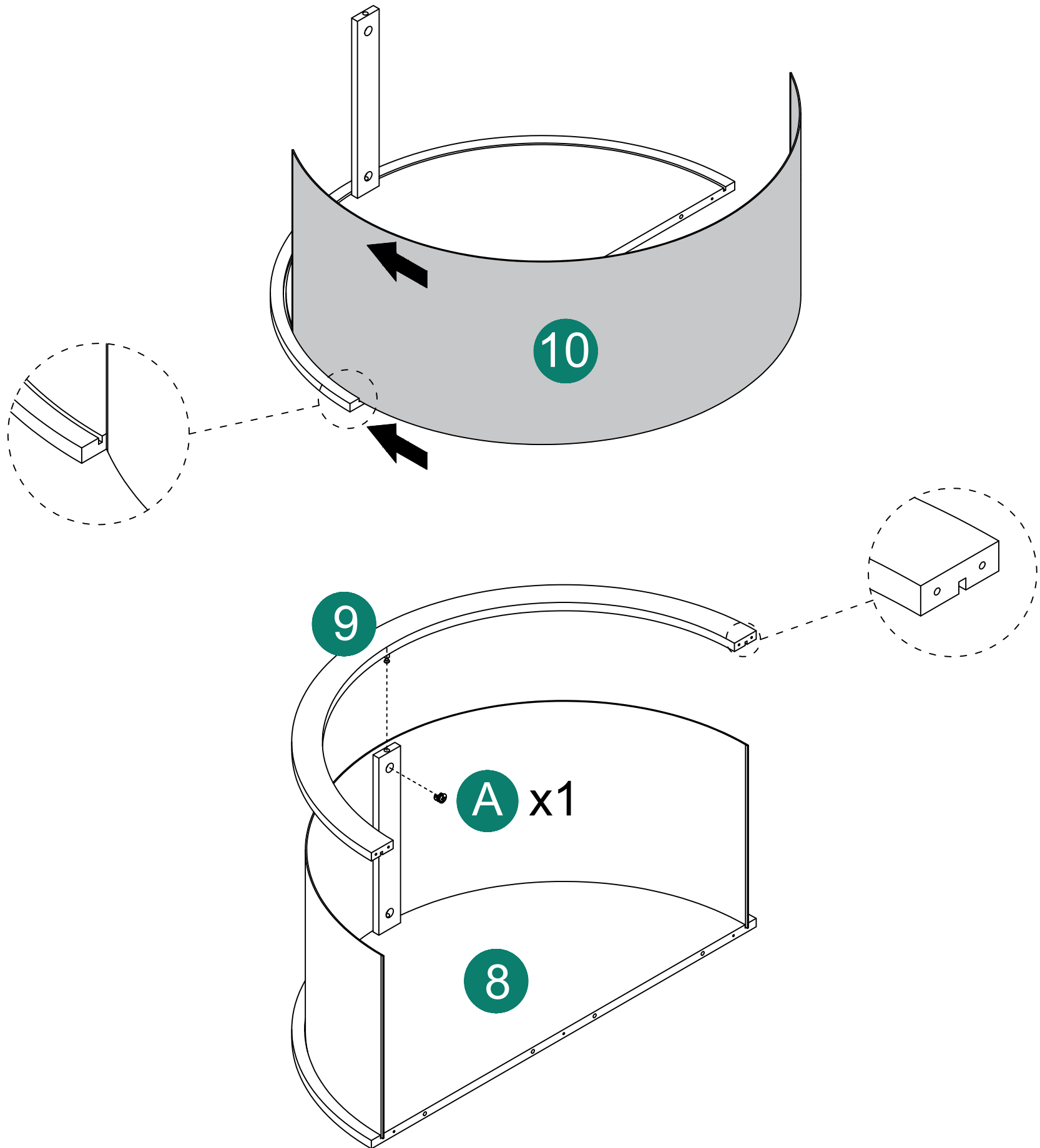
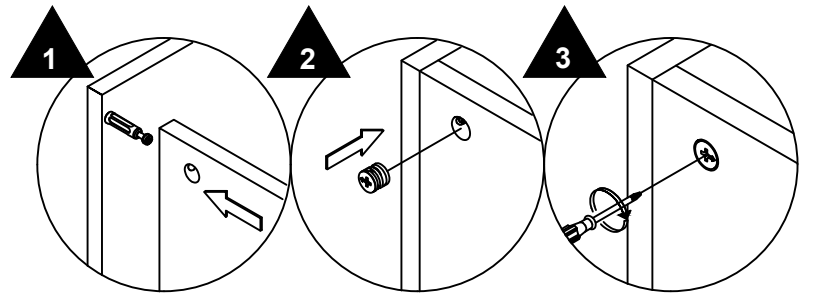
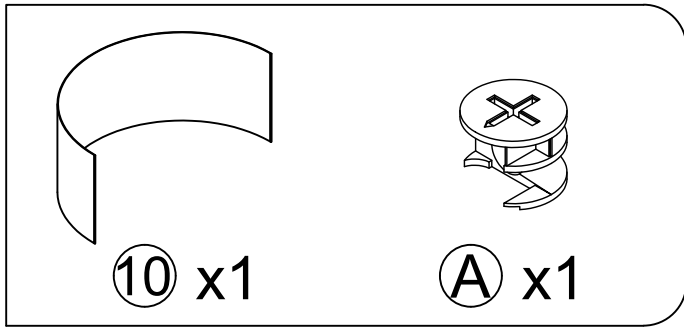

16

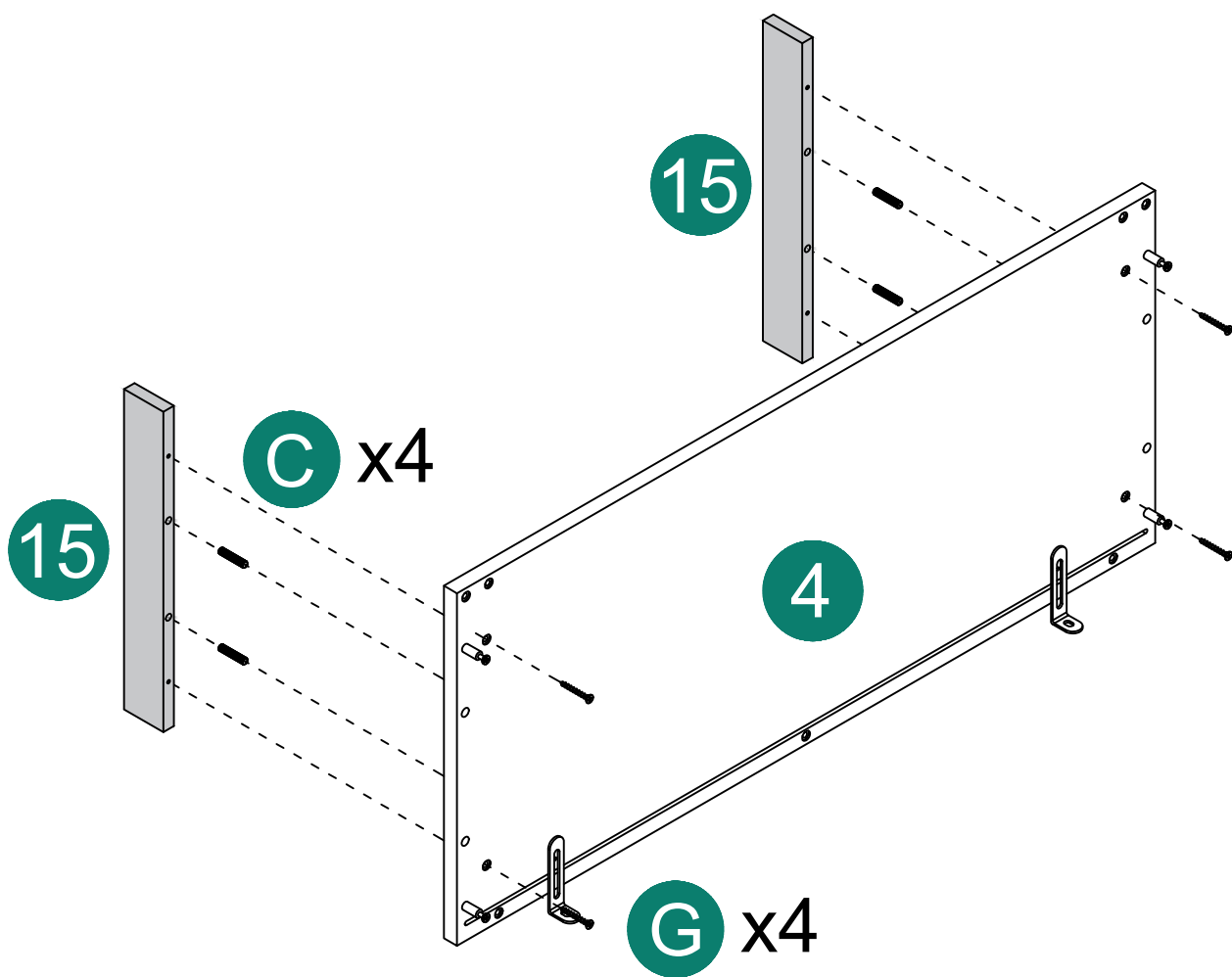
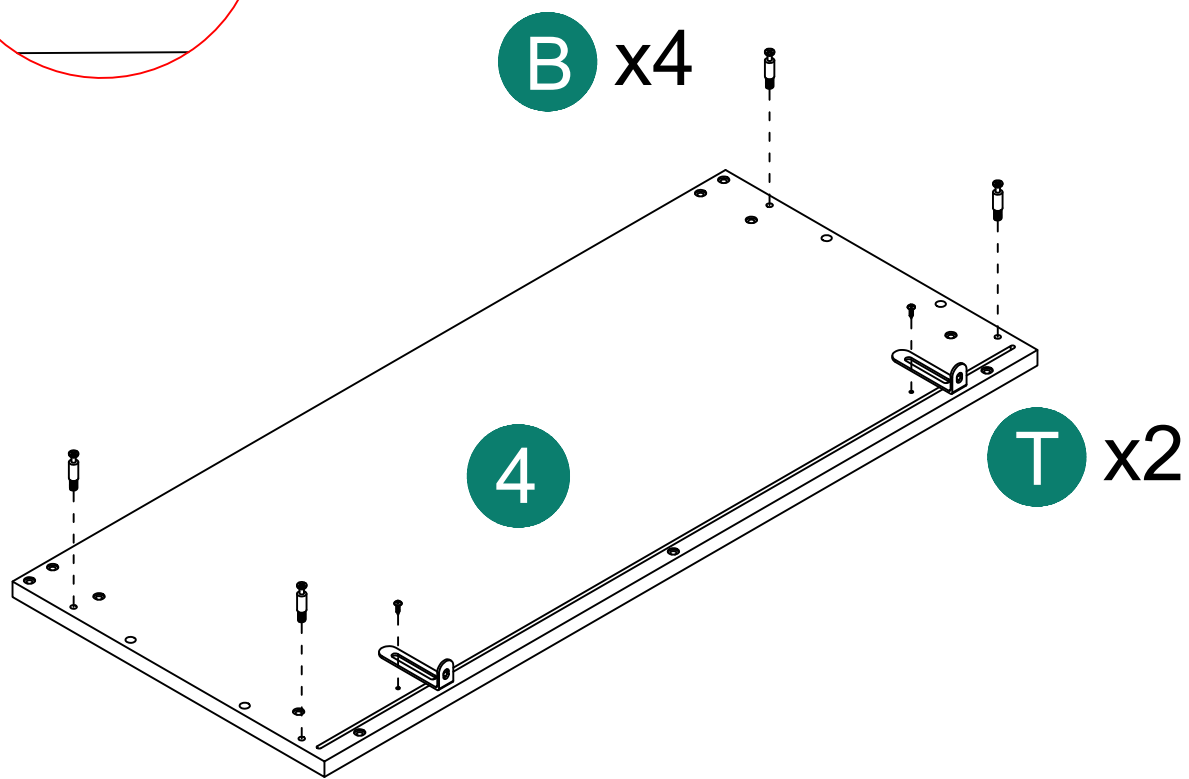
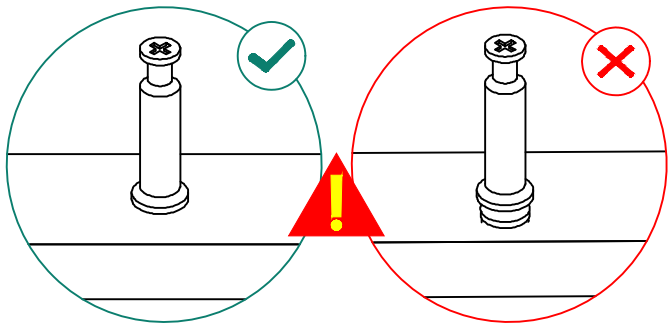
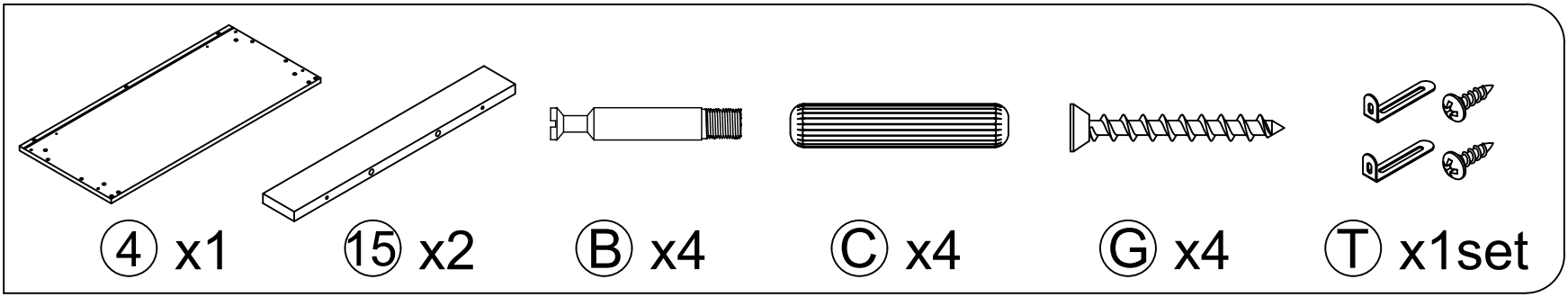

17

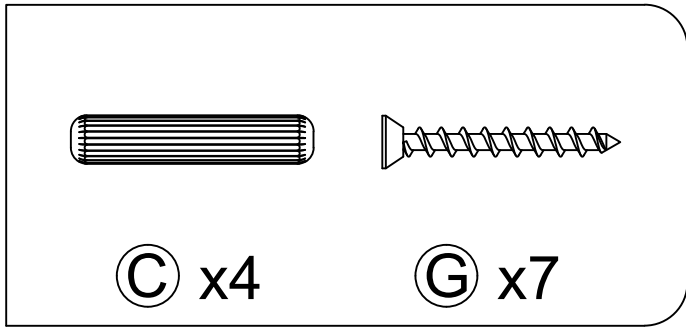

YOU NEED ONE HELPER FOR THIS STEP

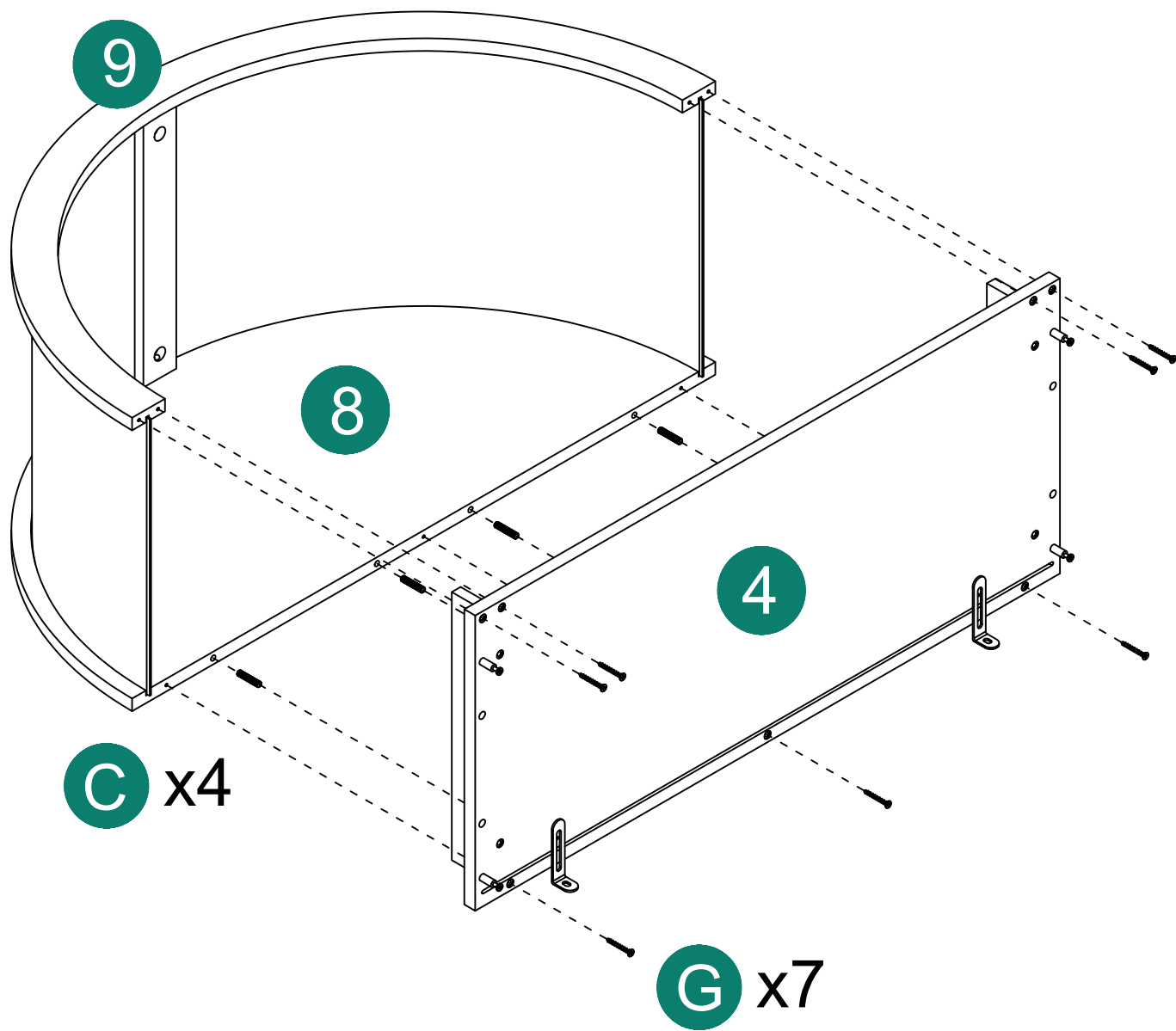

18

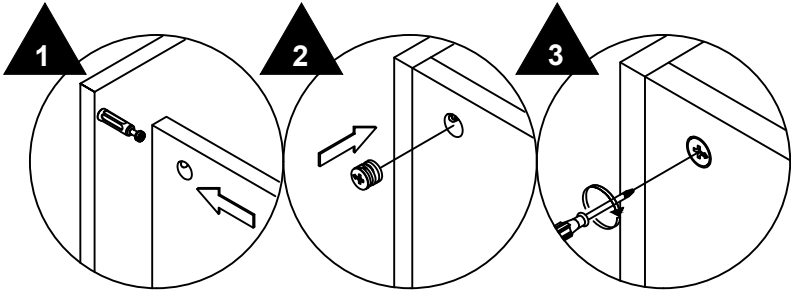
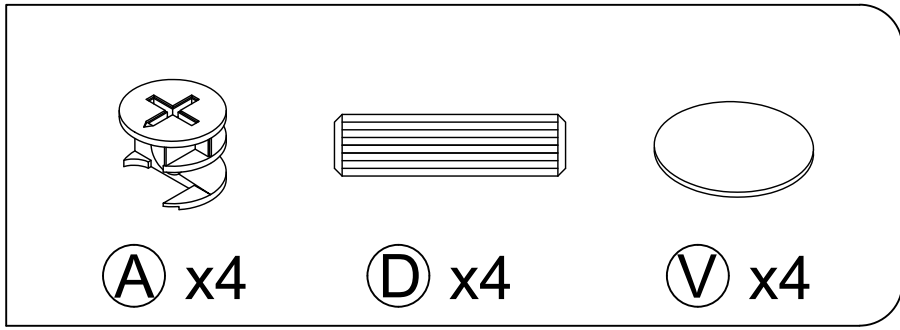

Note the slot on the back.

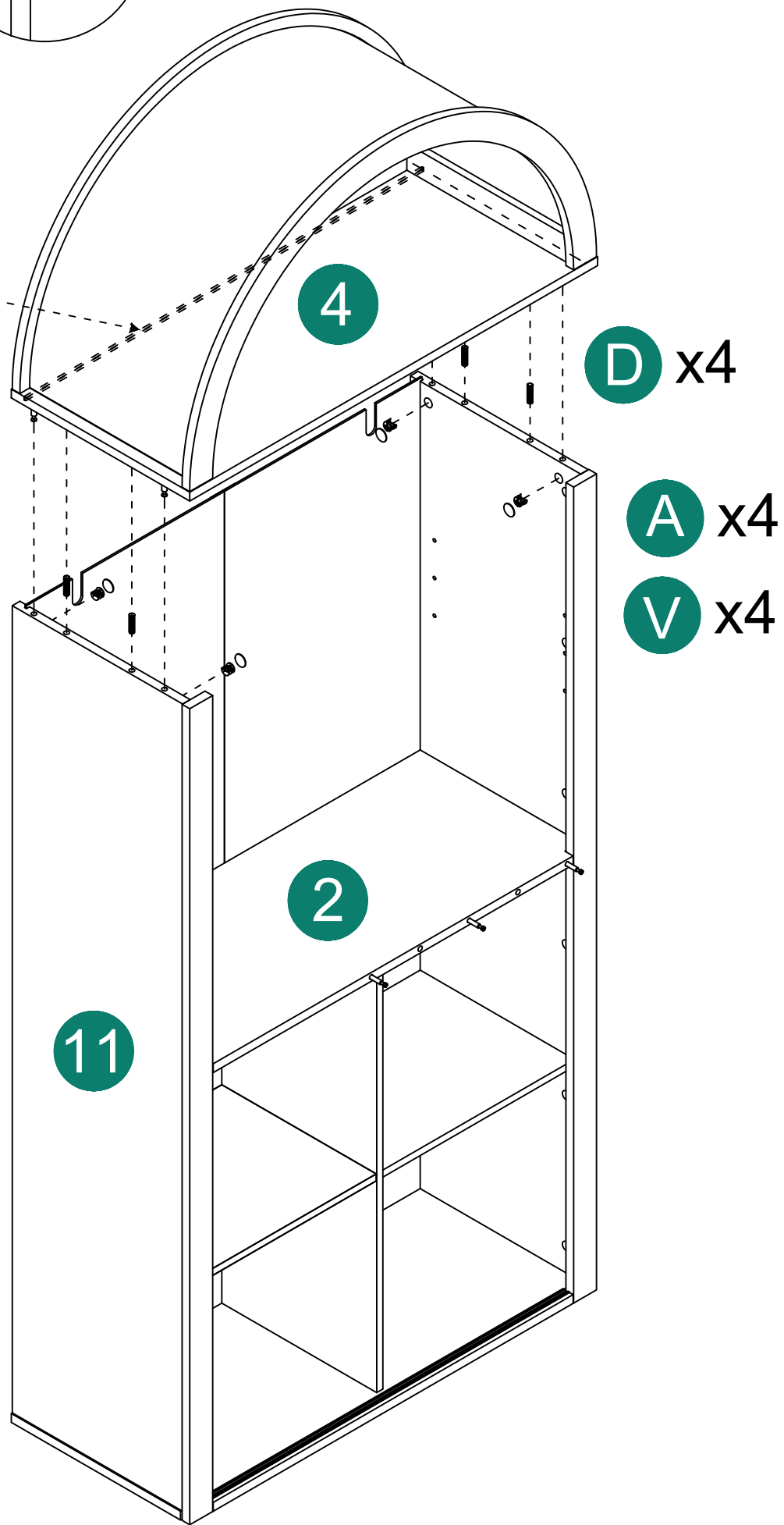

19

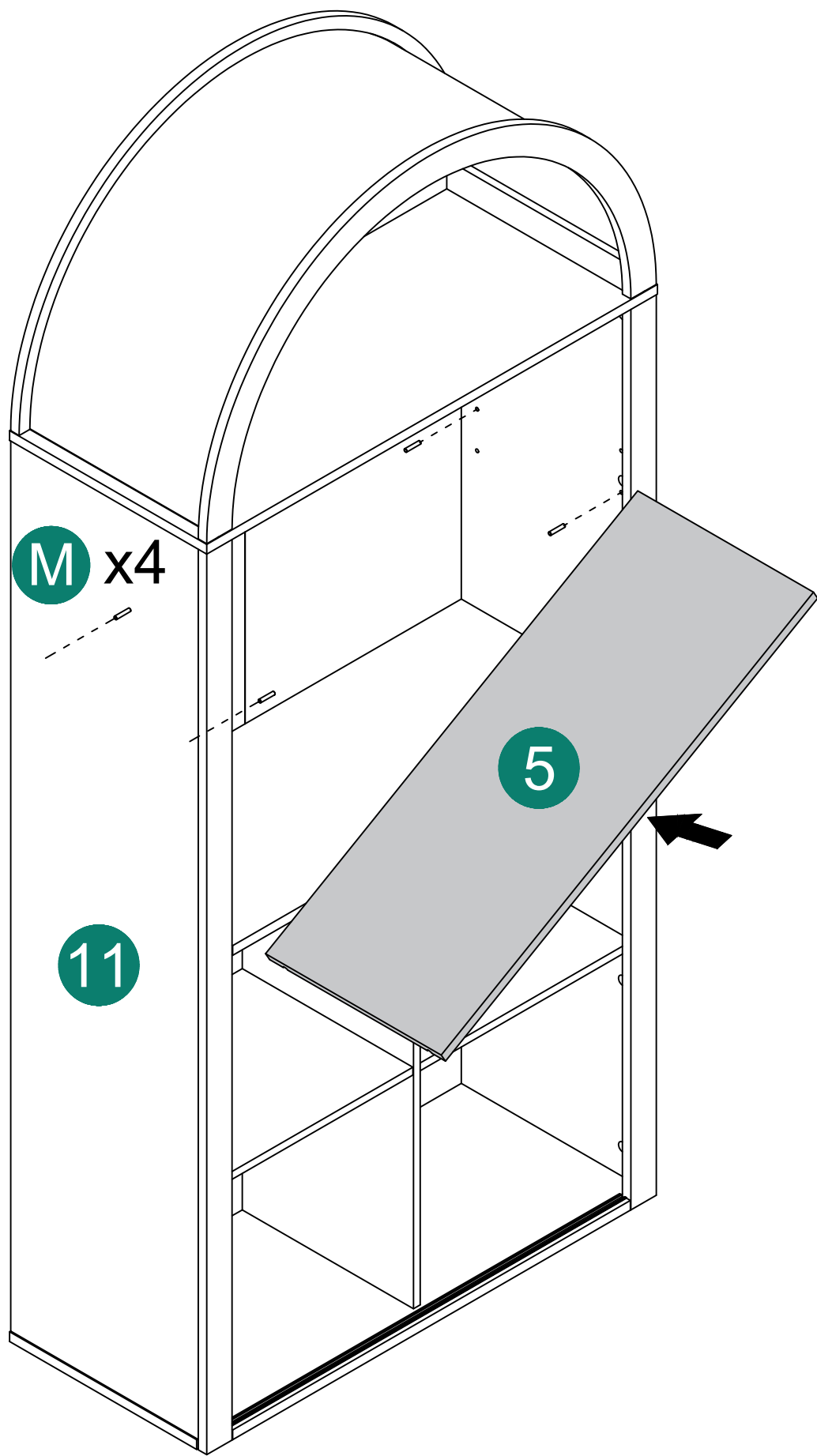
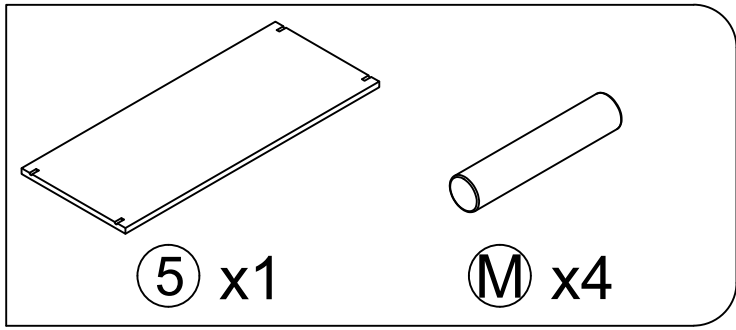

20

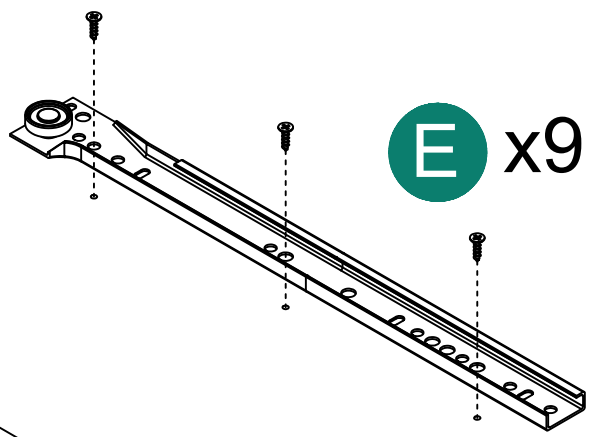
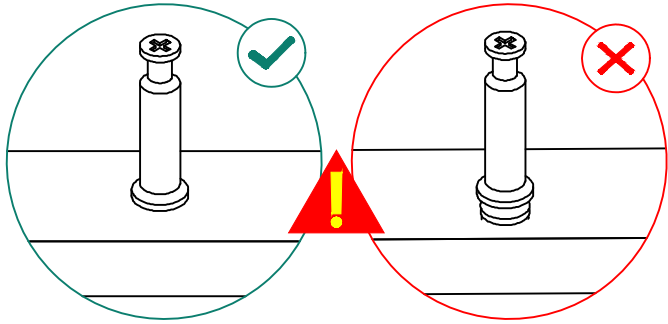
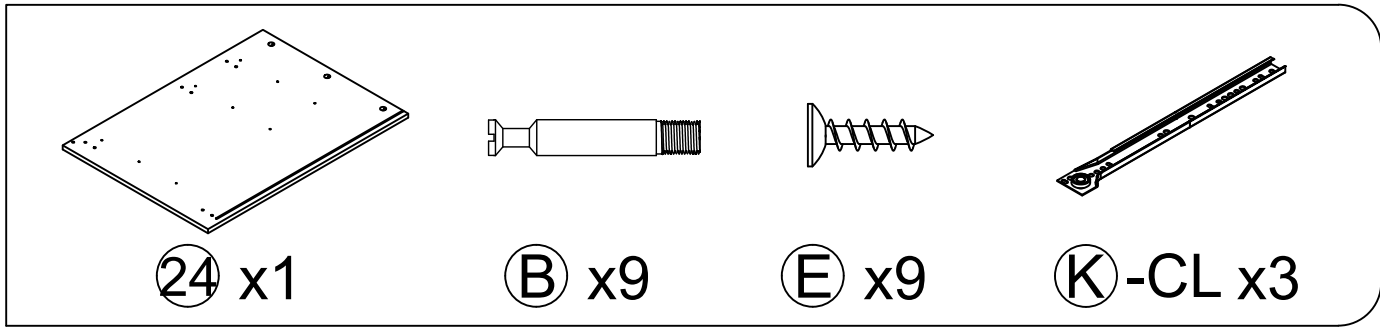

K-CL x3

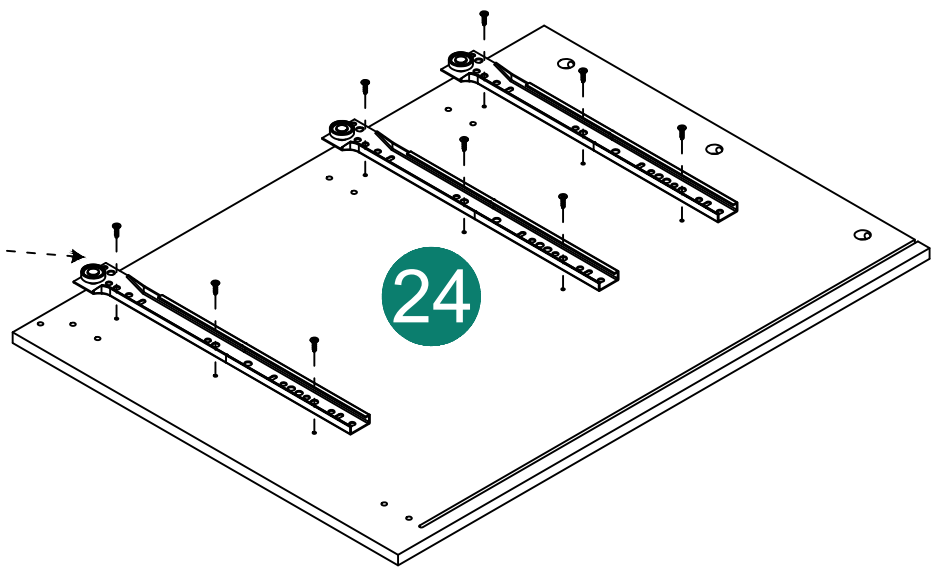
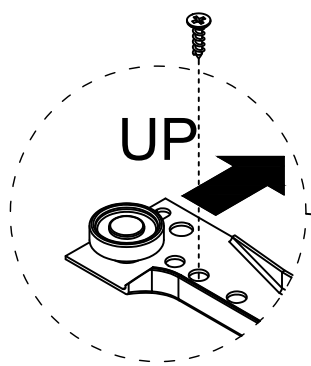

B x9

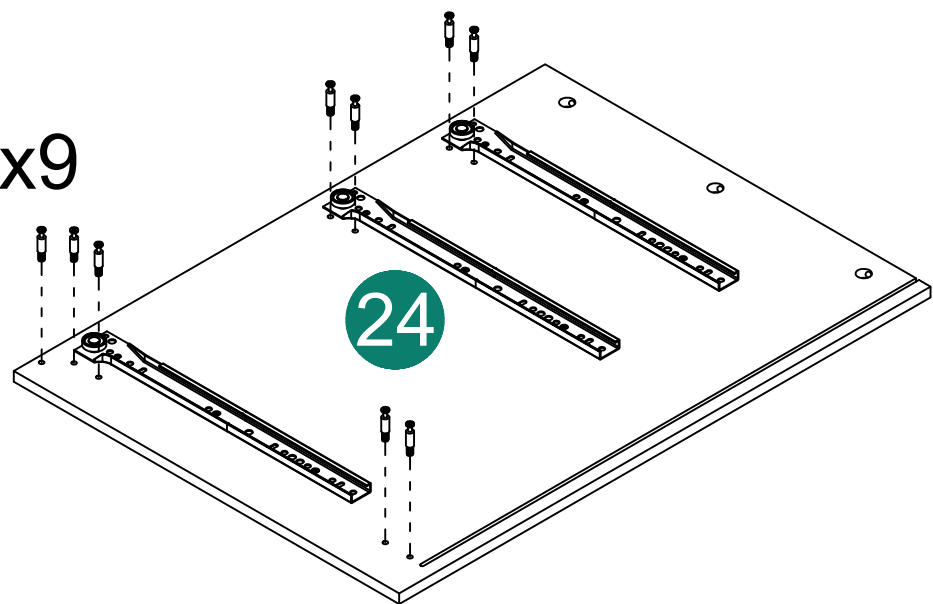

21

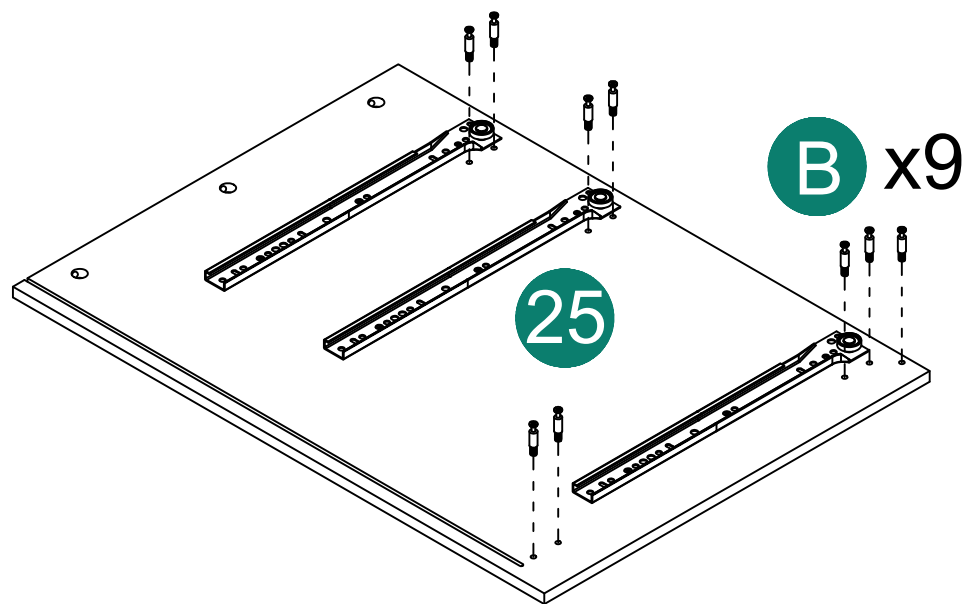
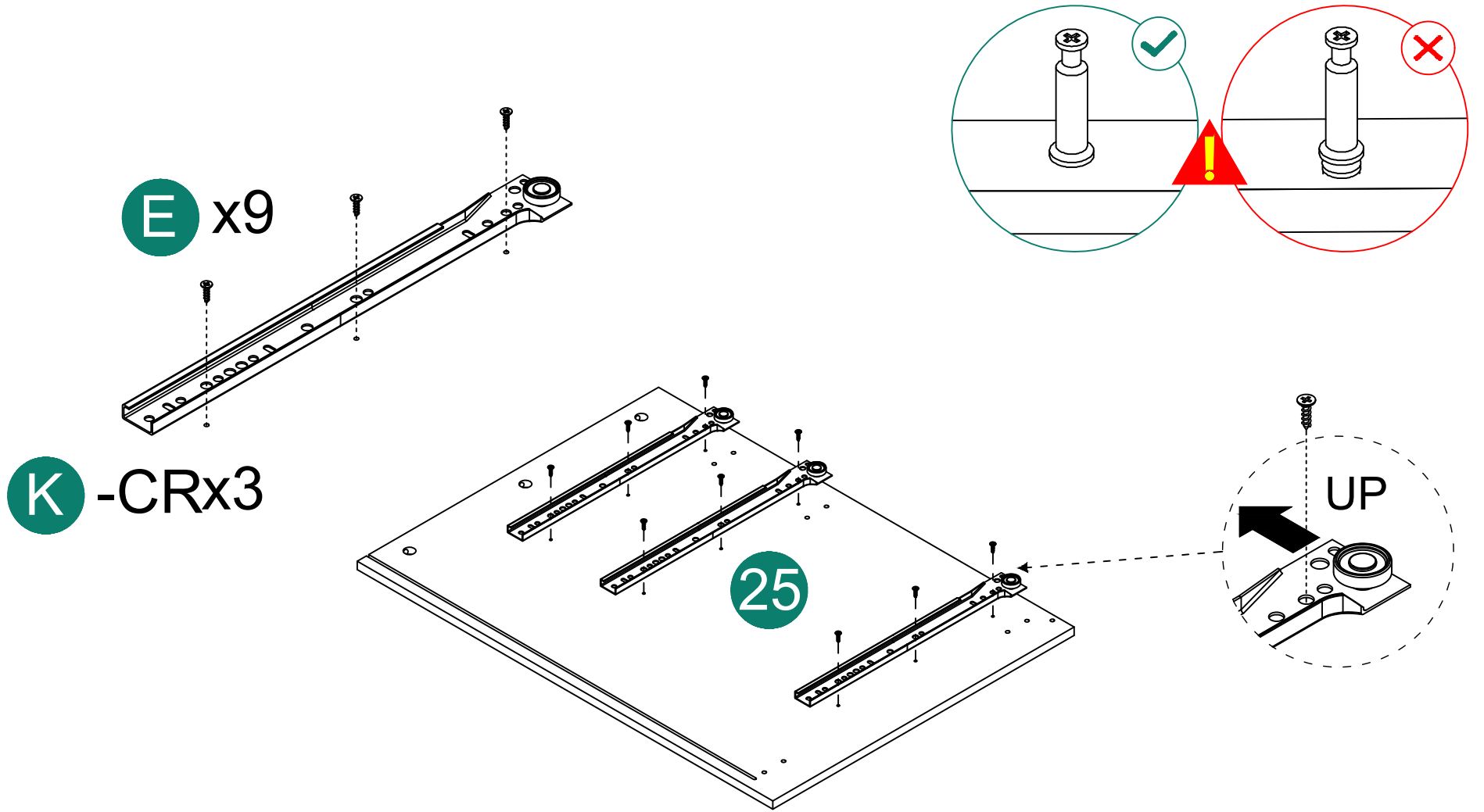
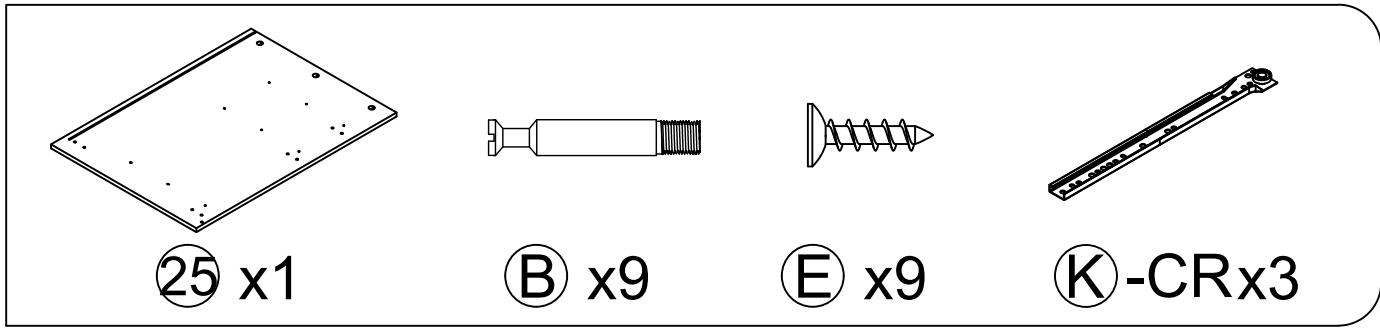

22

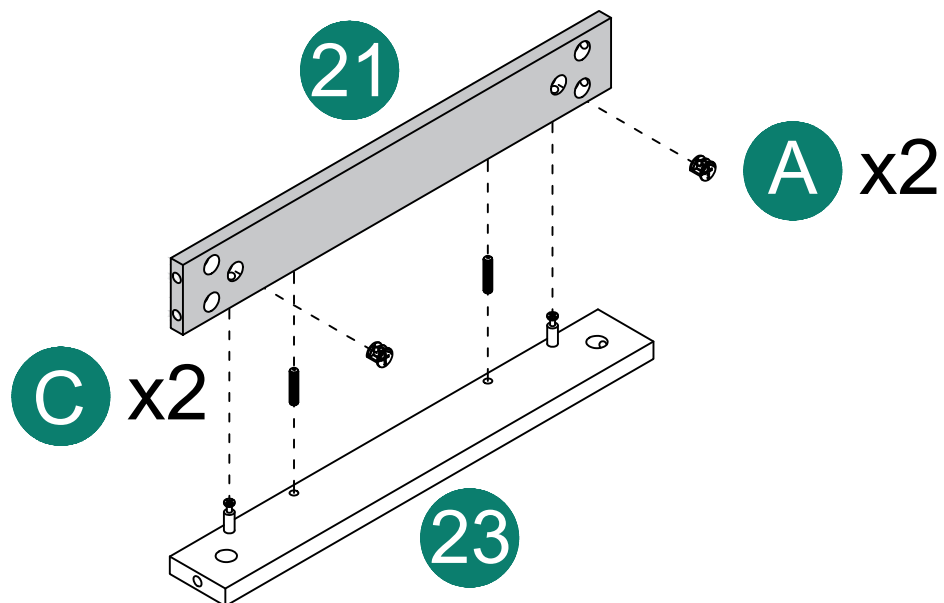
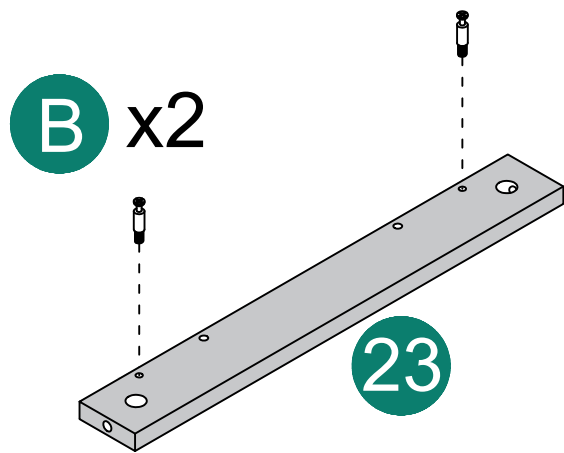
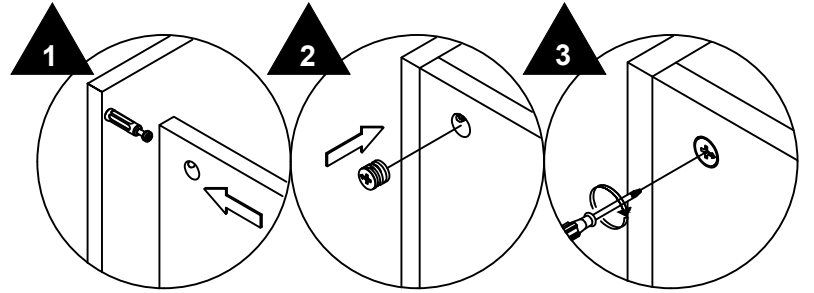
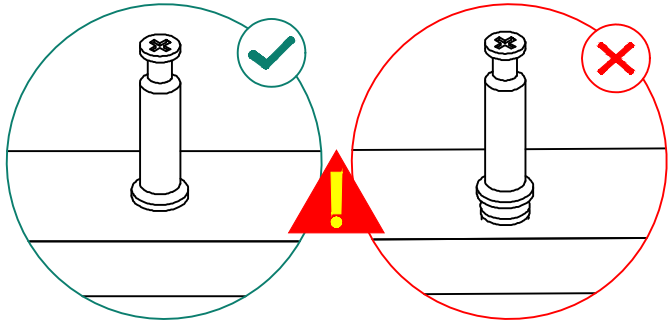
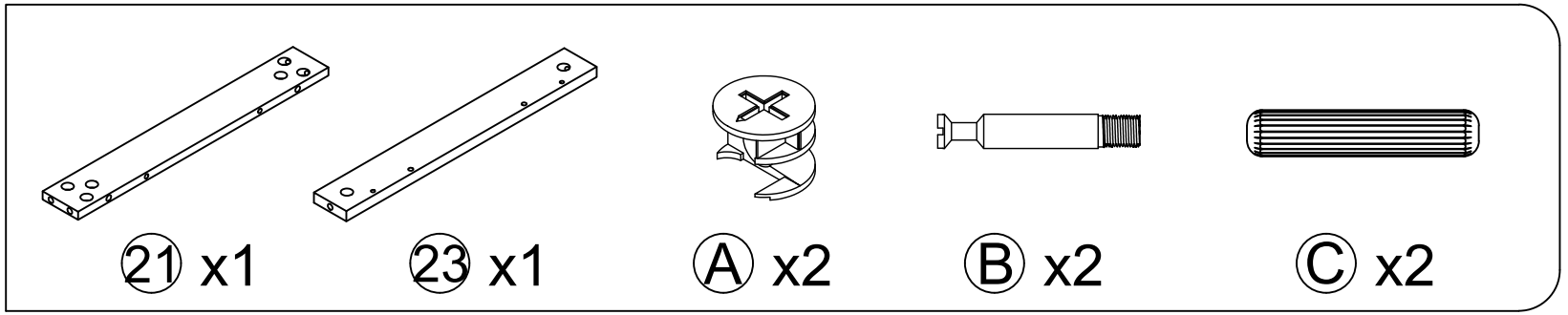

23

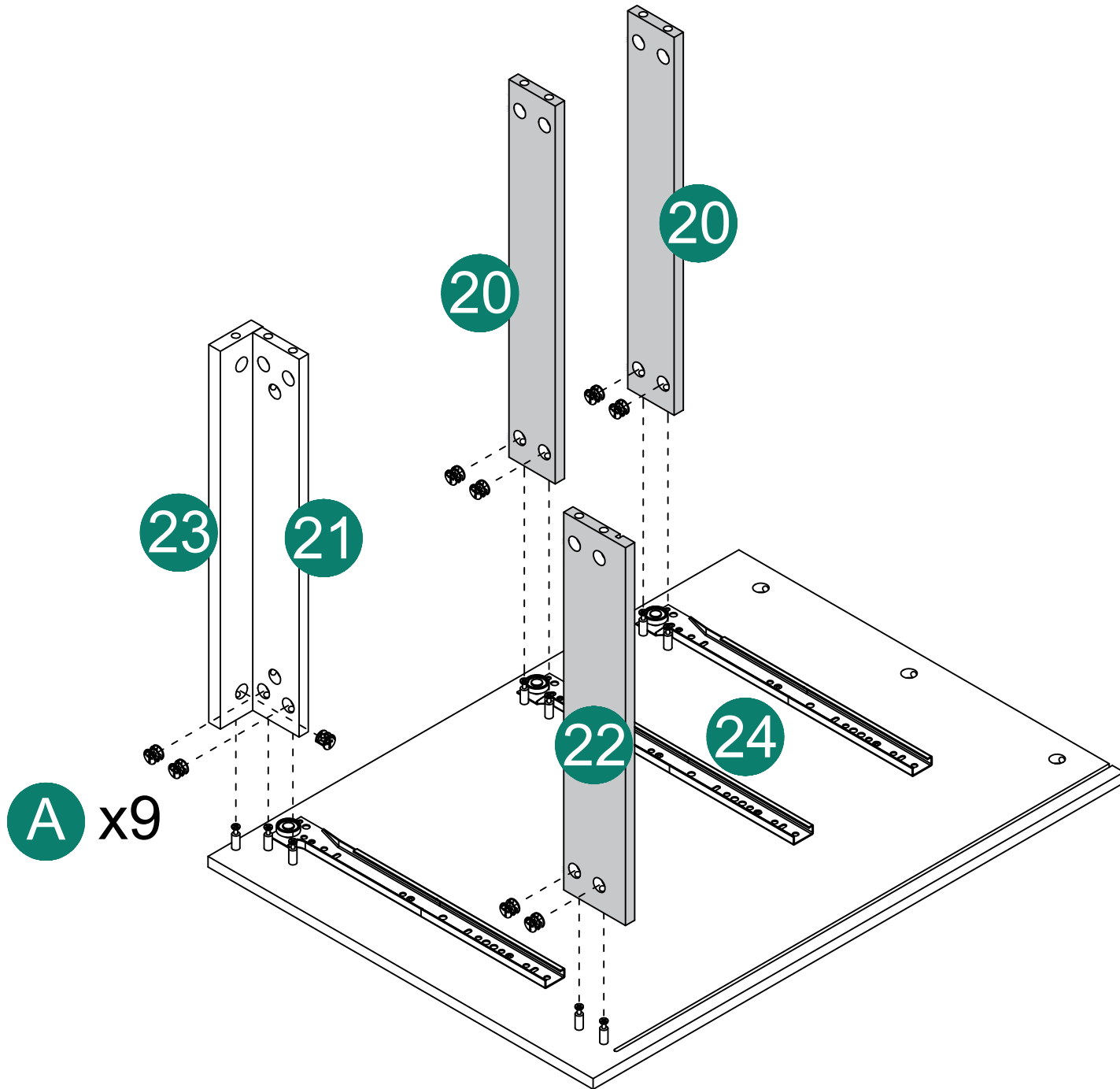
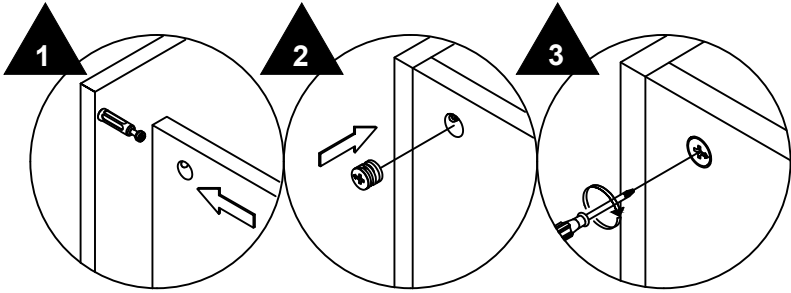
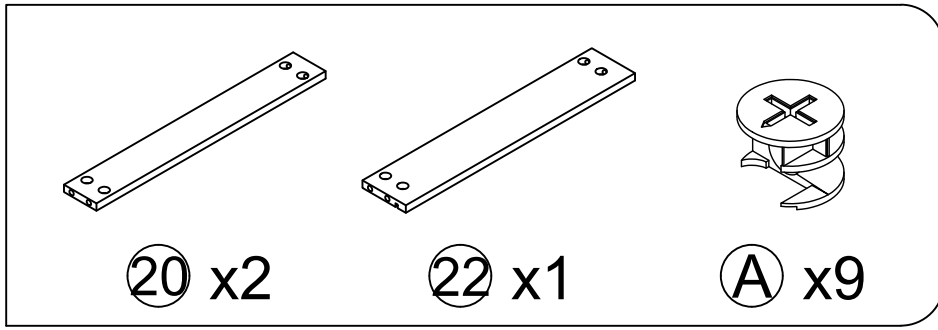

24

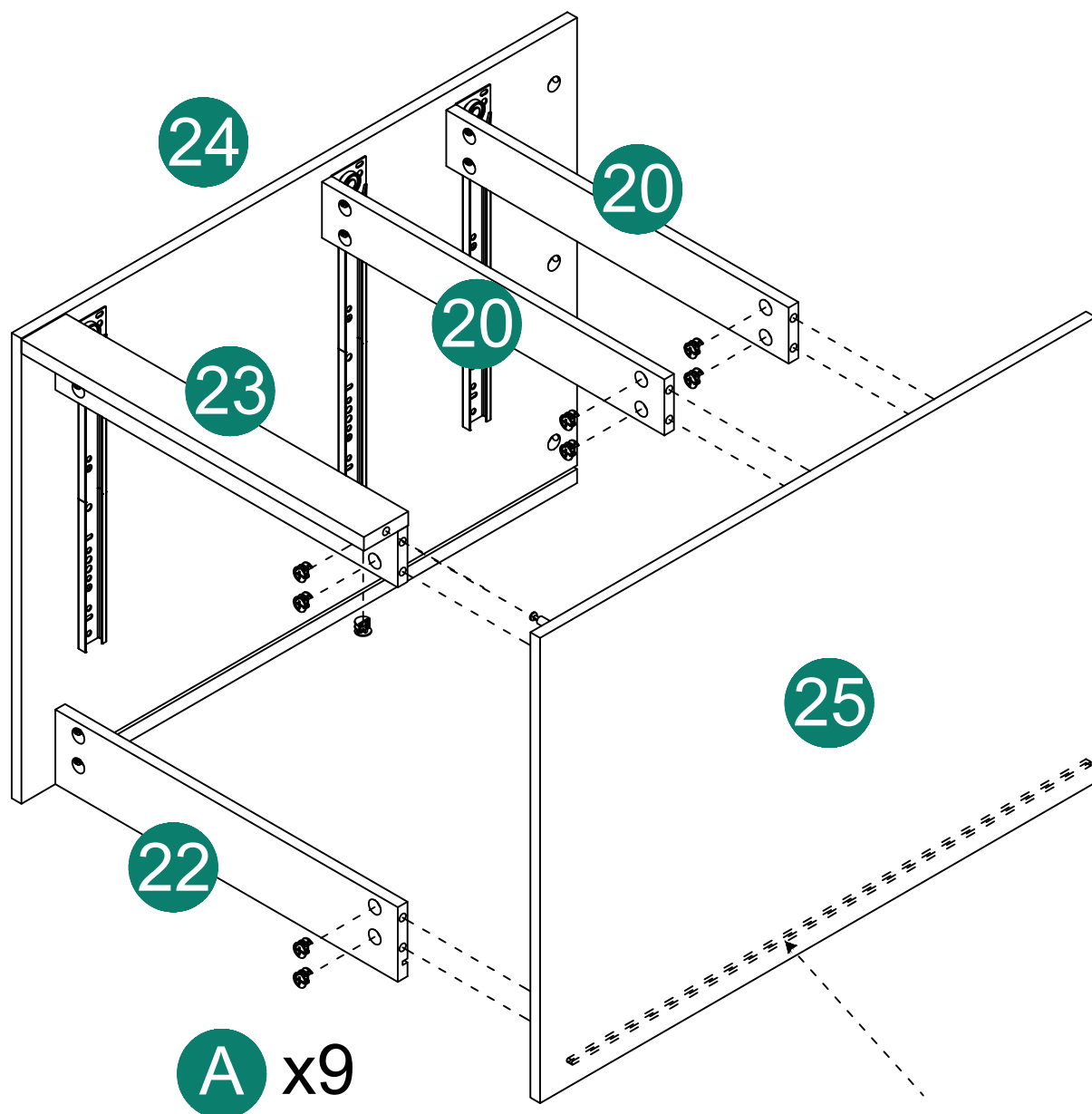
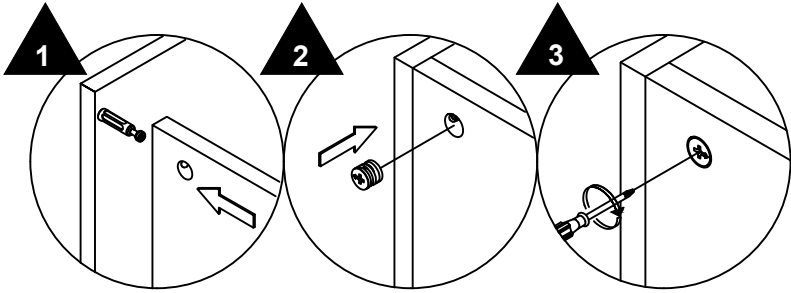
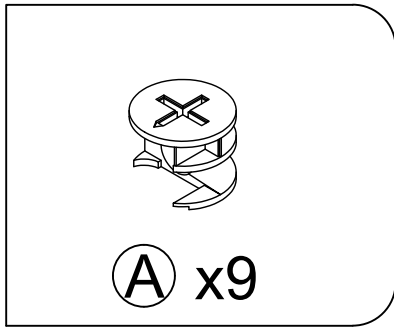

Note the slot on the back.

25

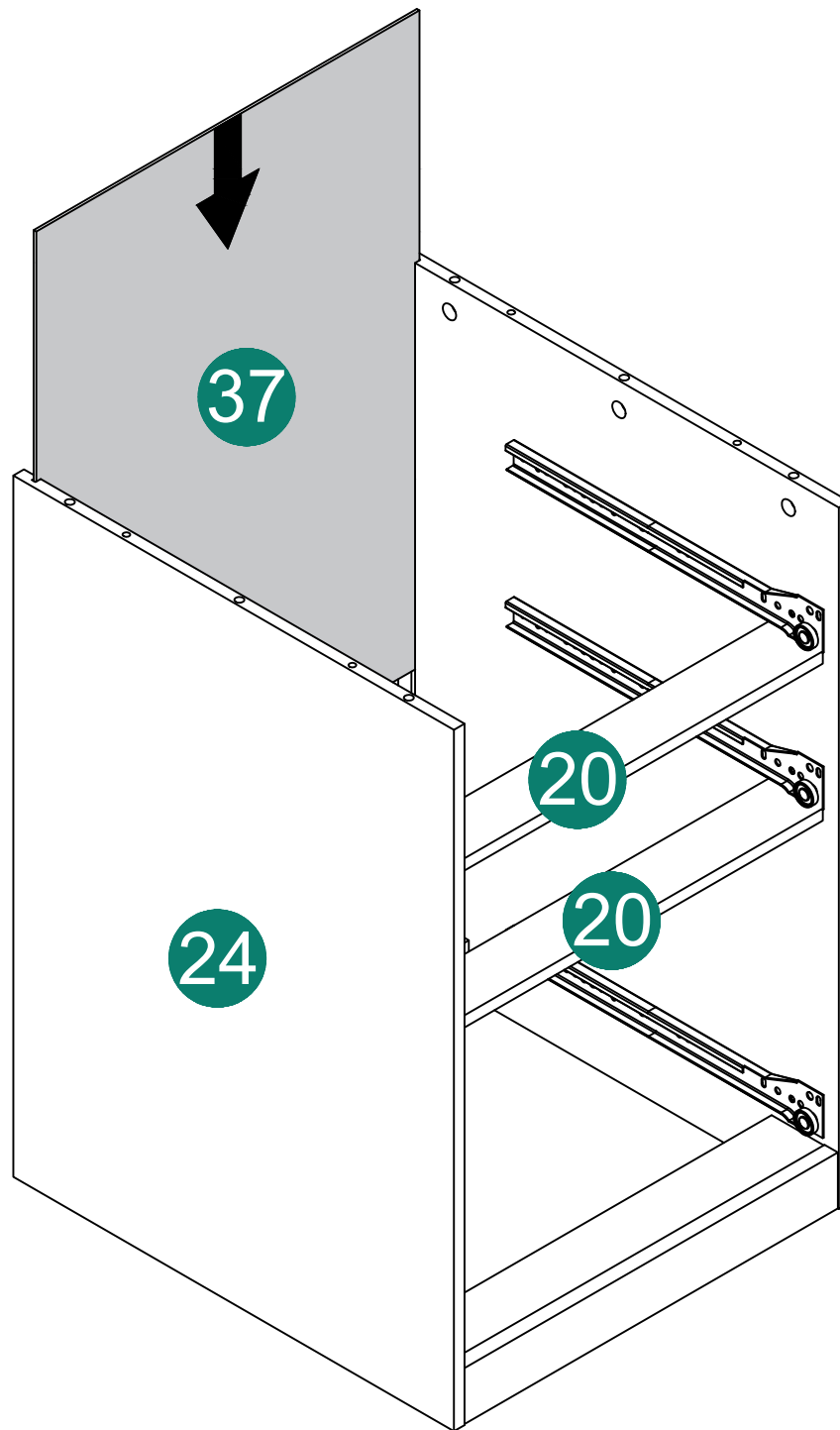
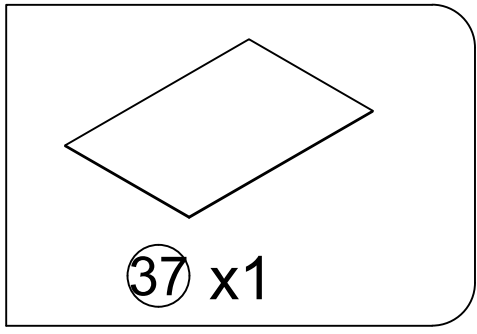

26

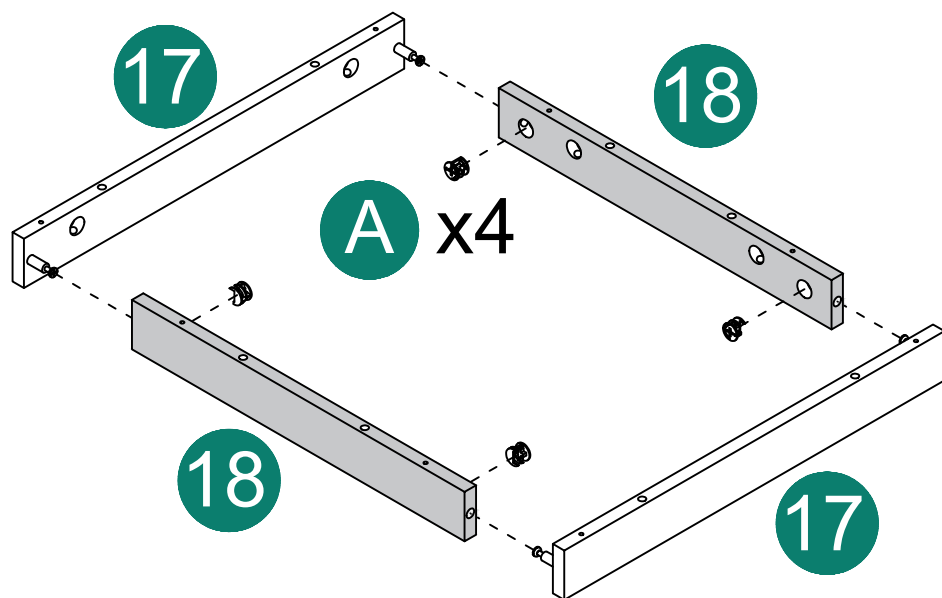
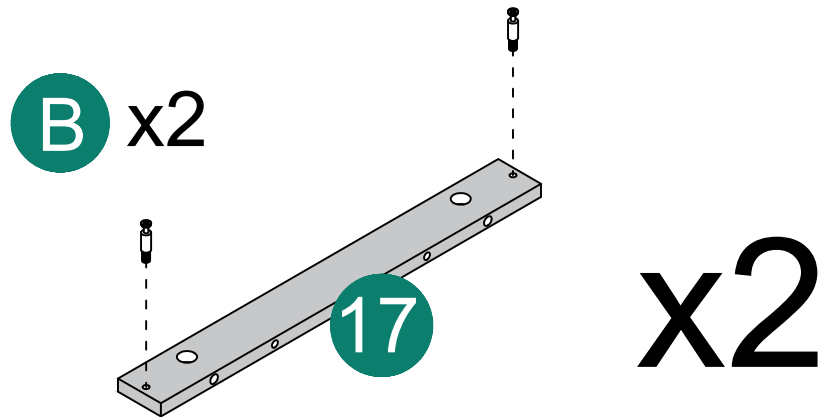
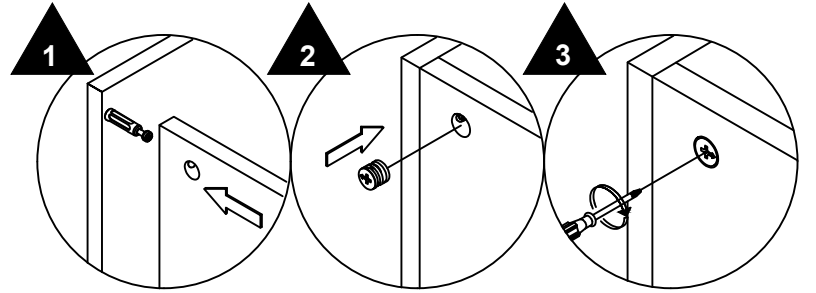
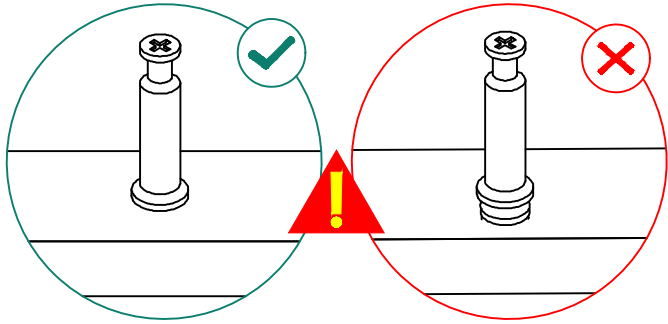
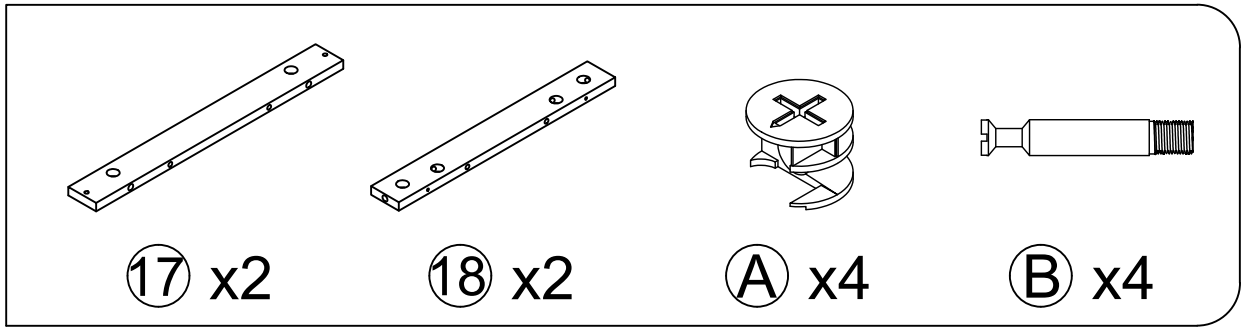

27

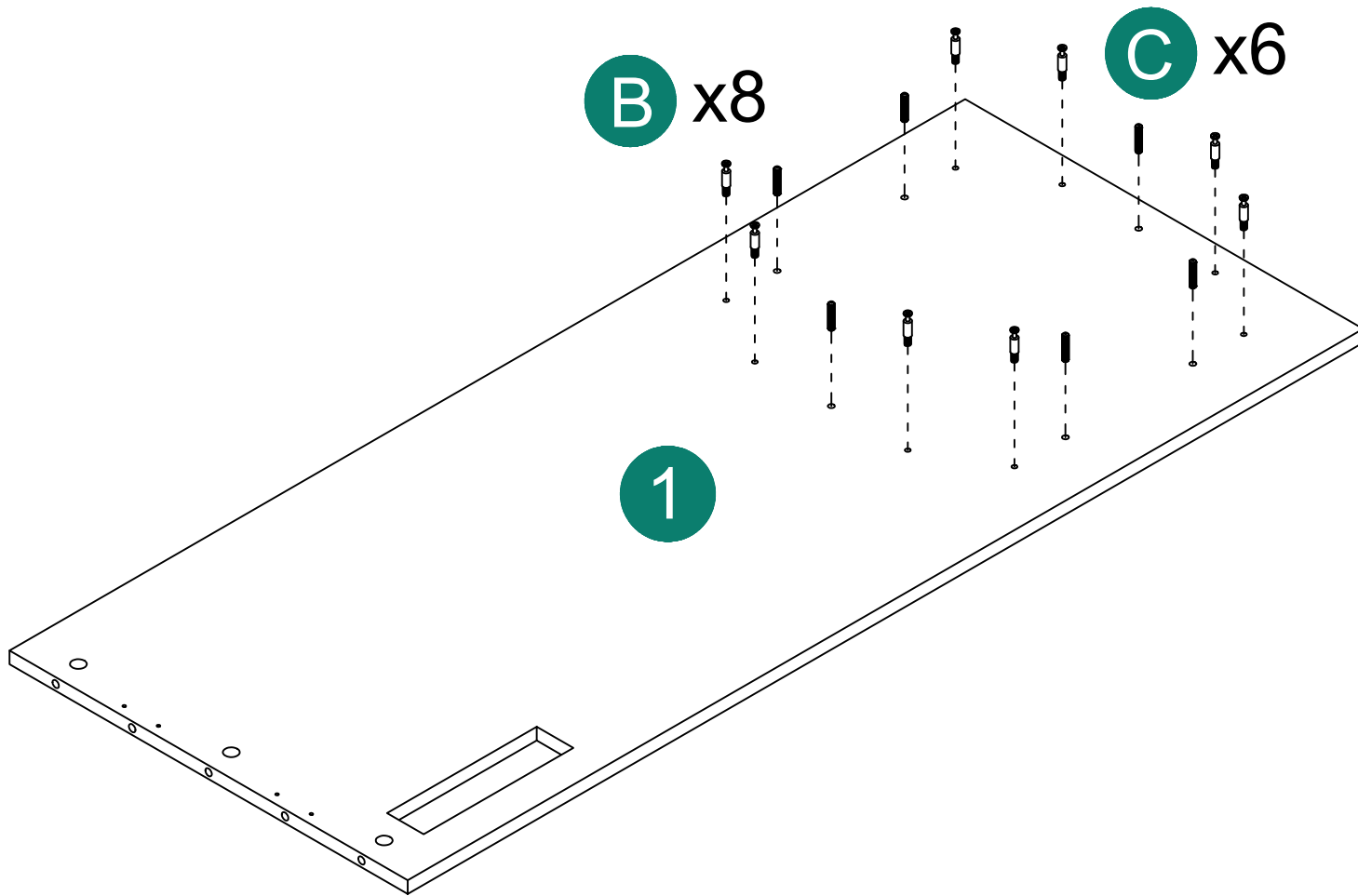
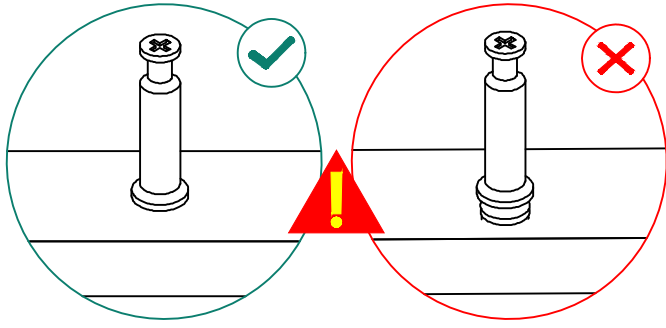
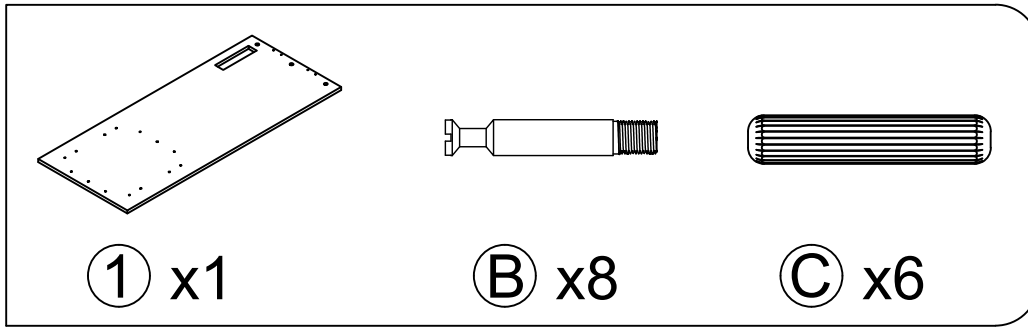

28

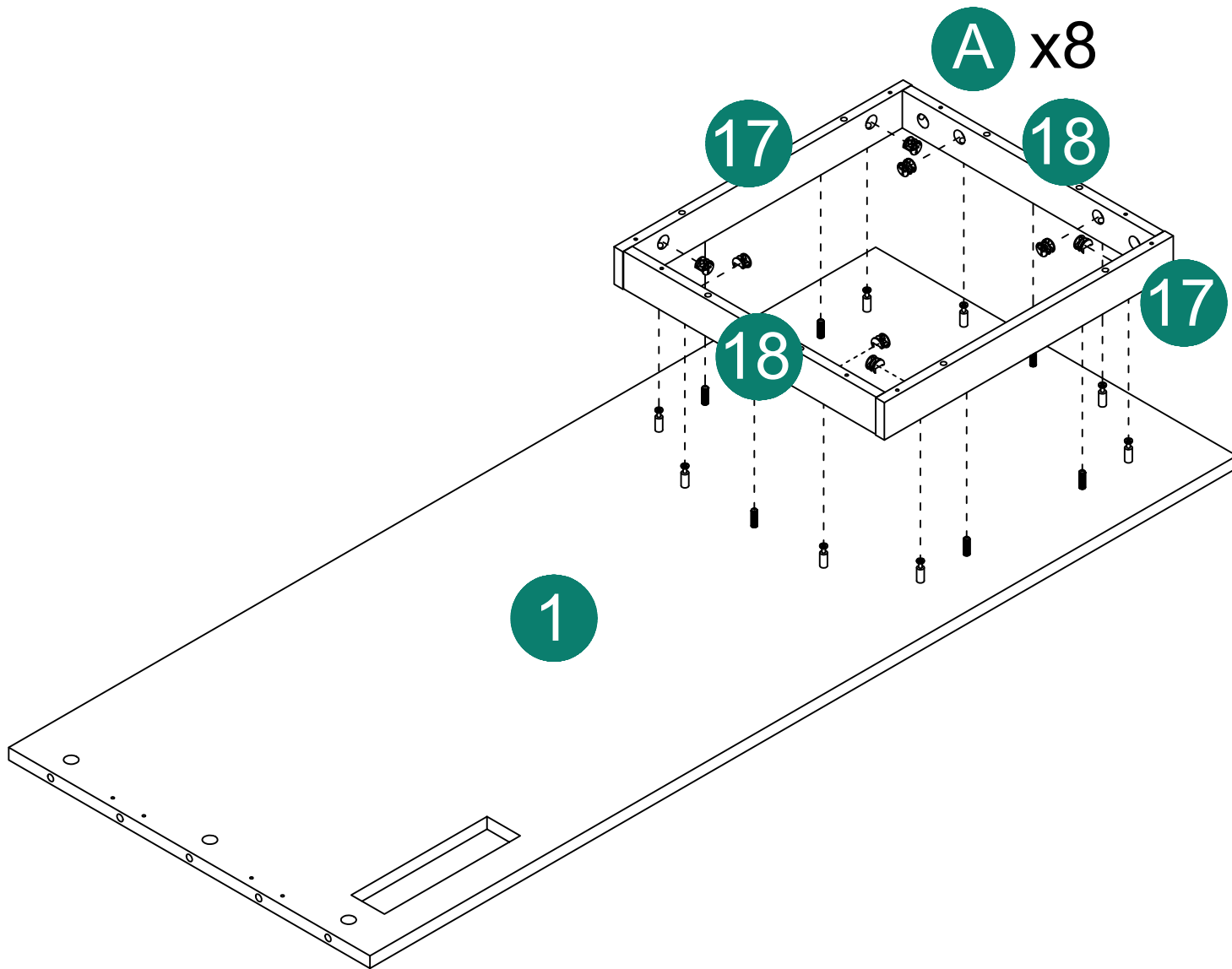
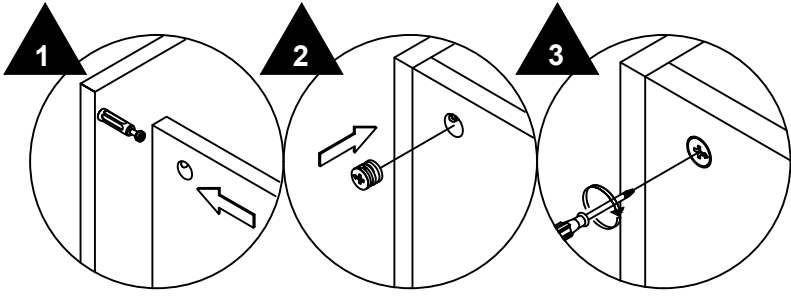
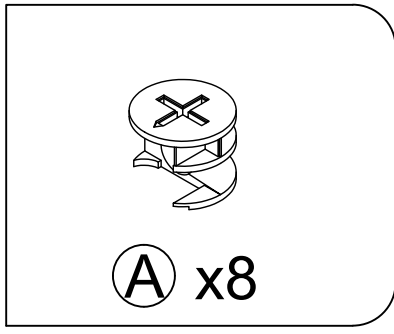

29

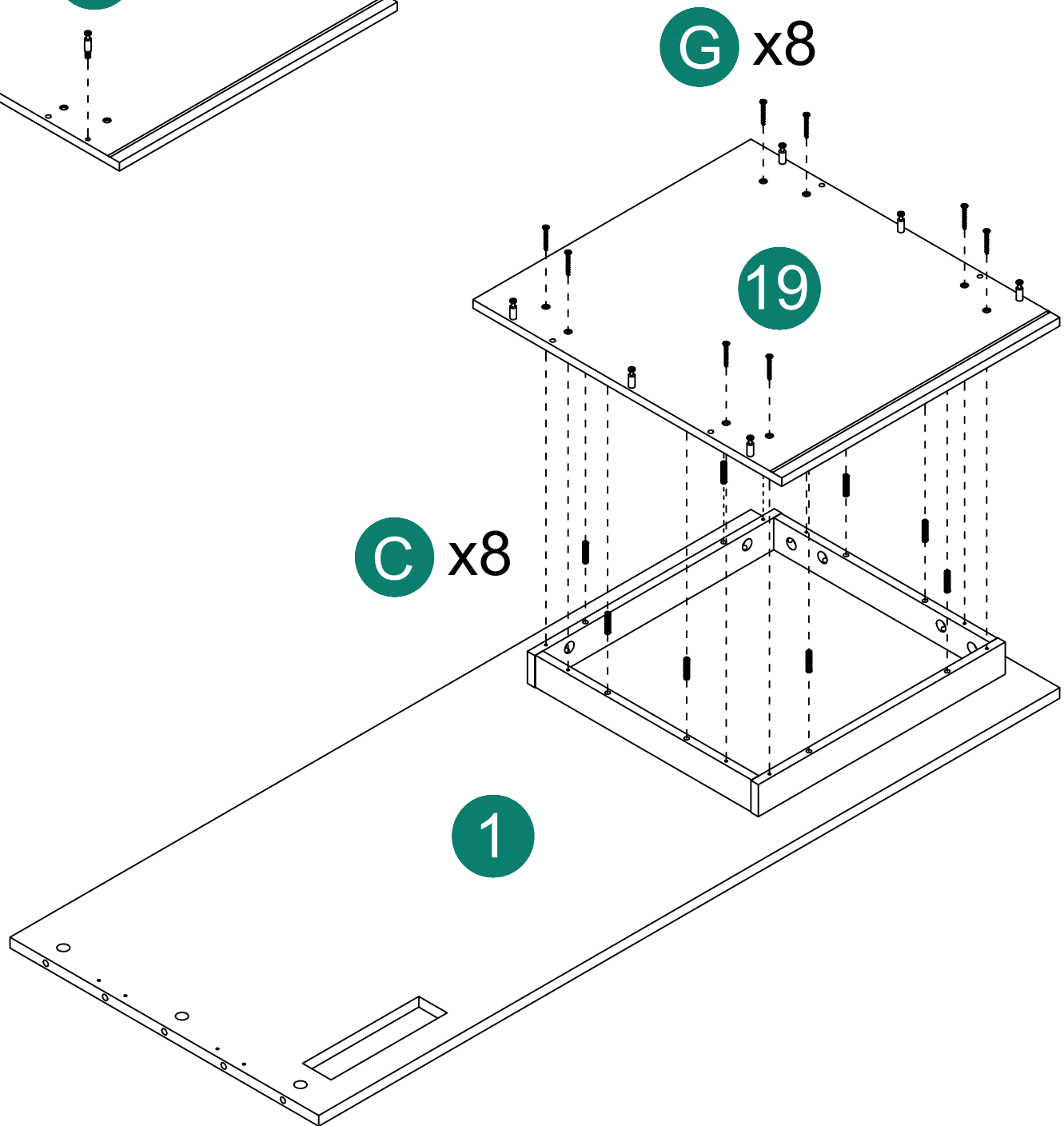
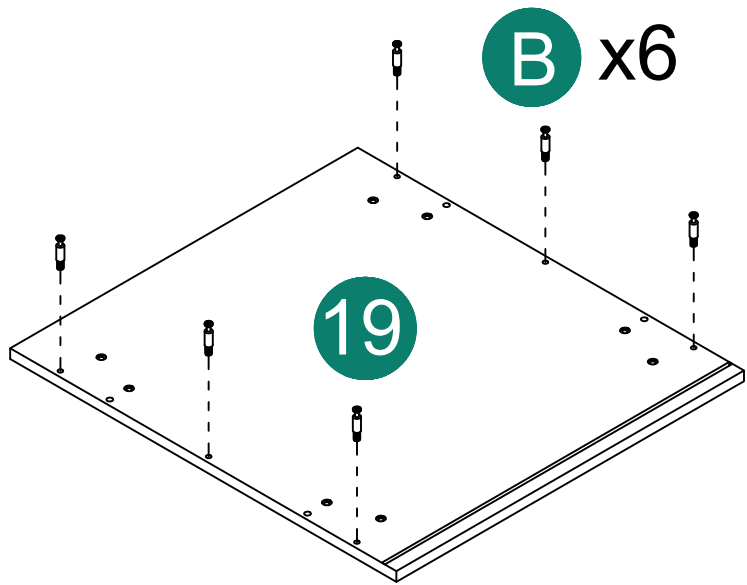
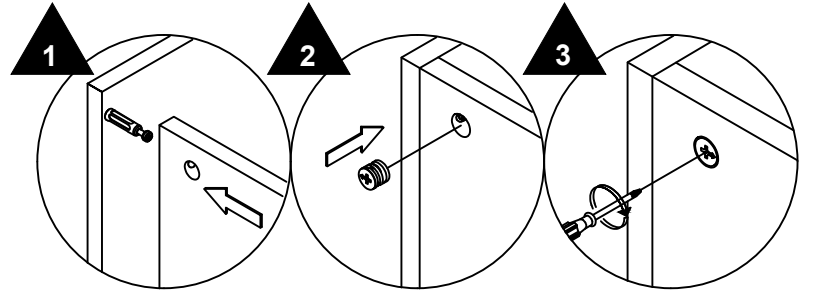
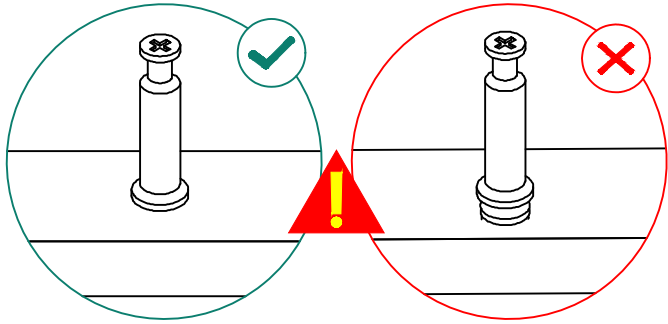
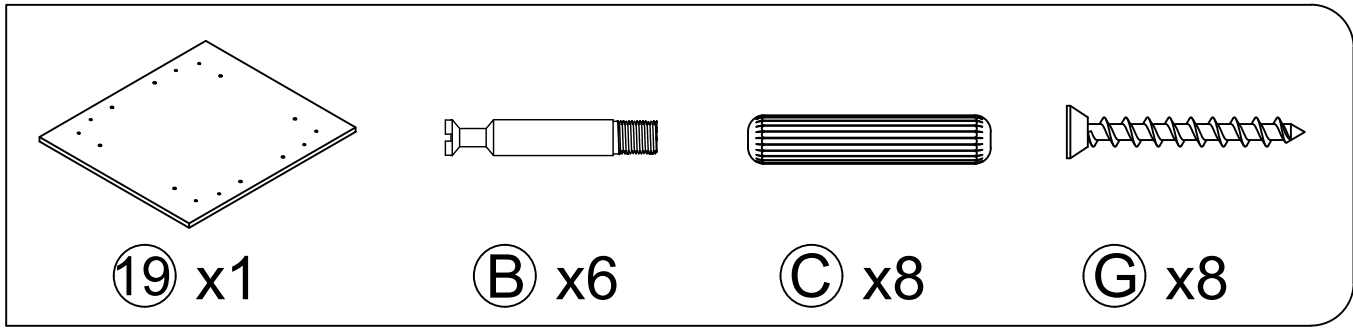

30

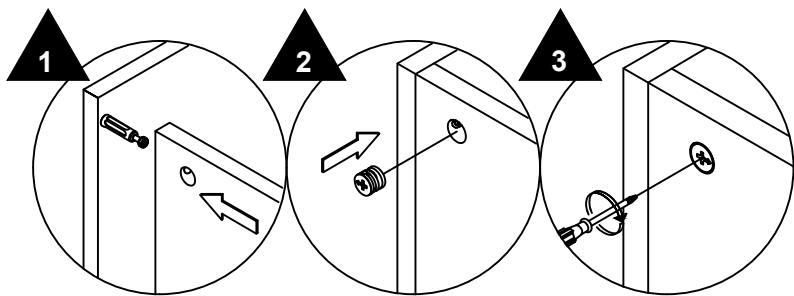
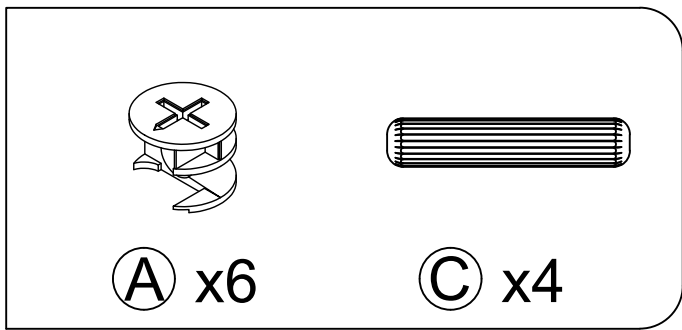

YOU NEED ONE HELPER FOR THIS STEP

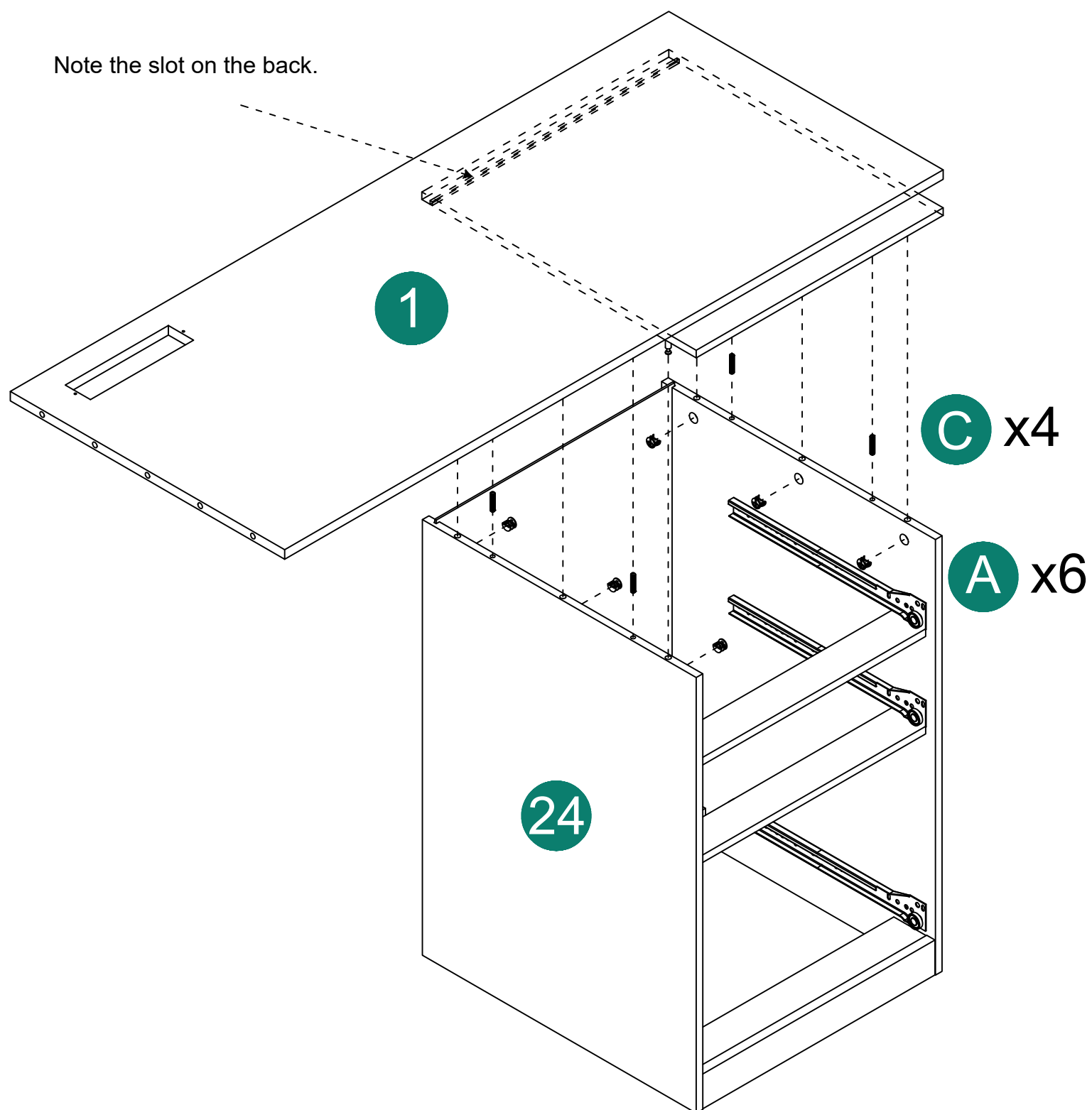

31

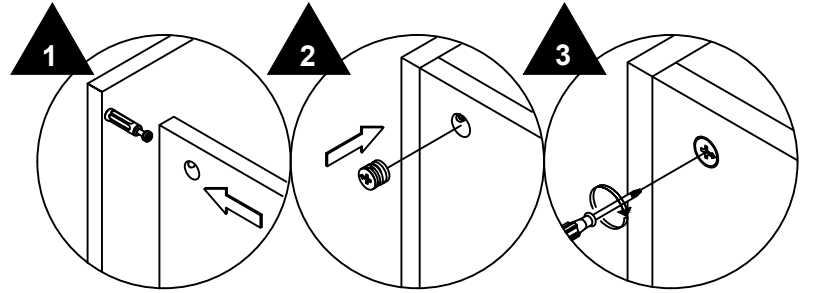
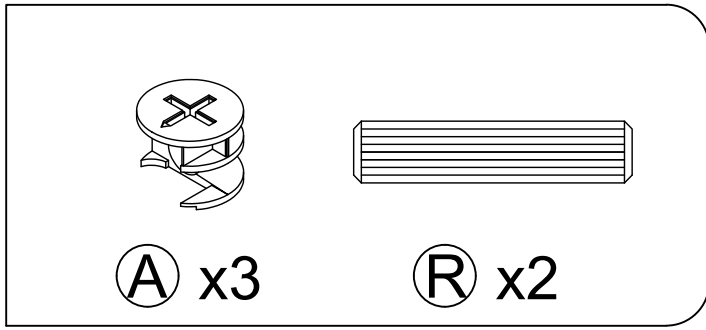

YOU NEED ONE HELPER FOR THIS STEP

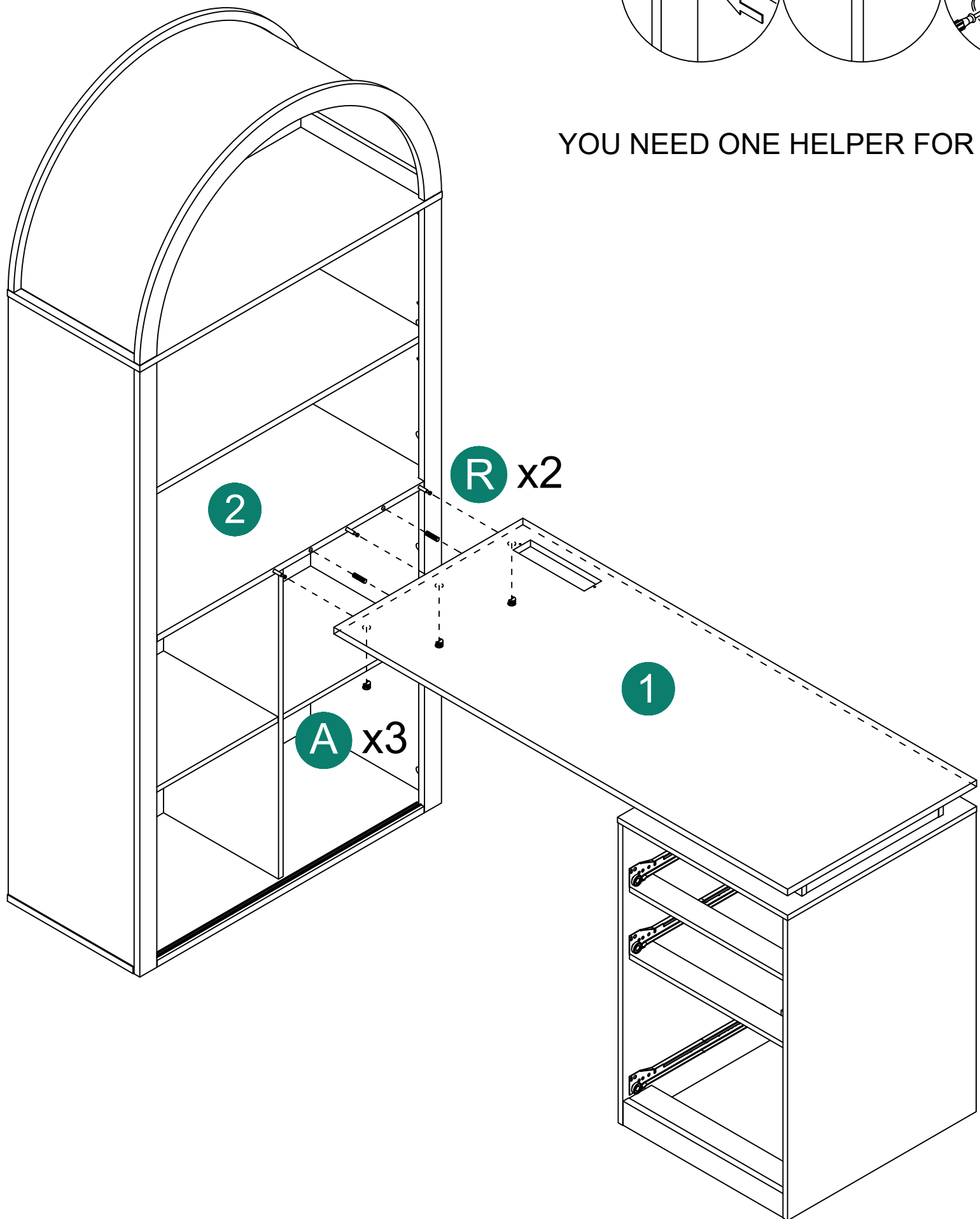

32

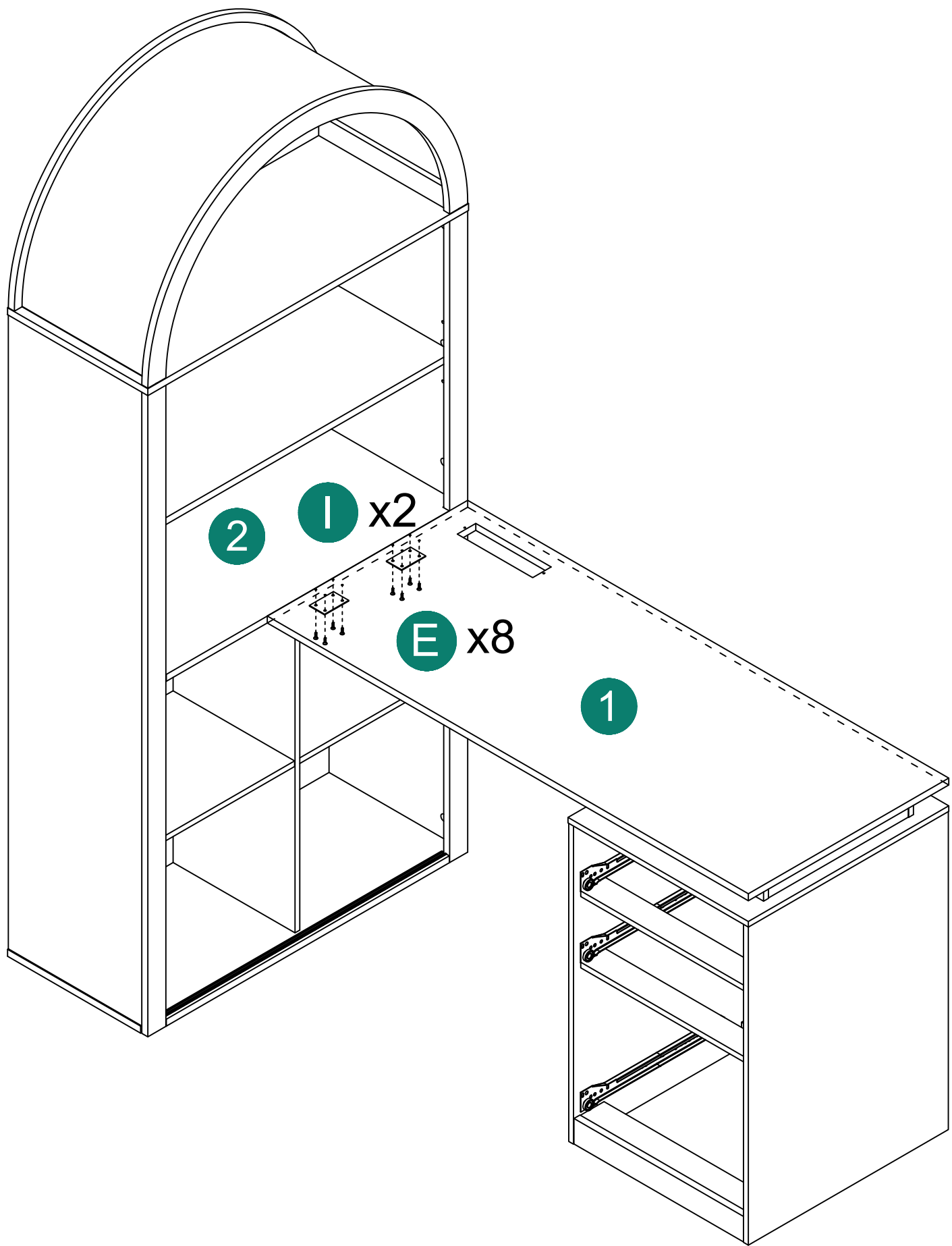
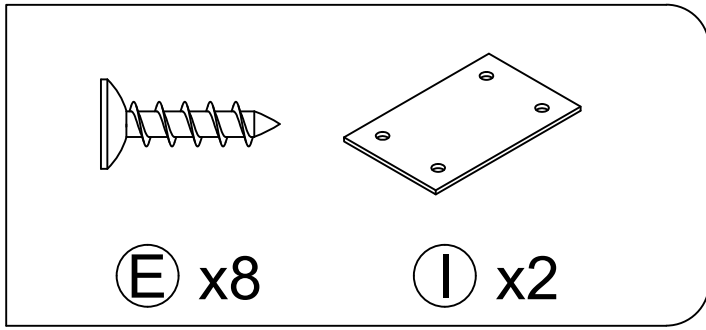

33

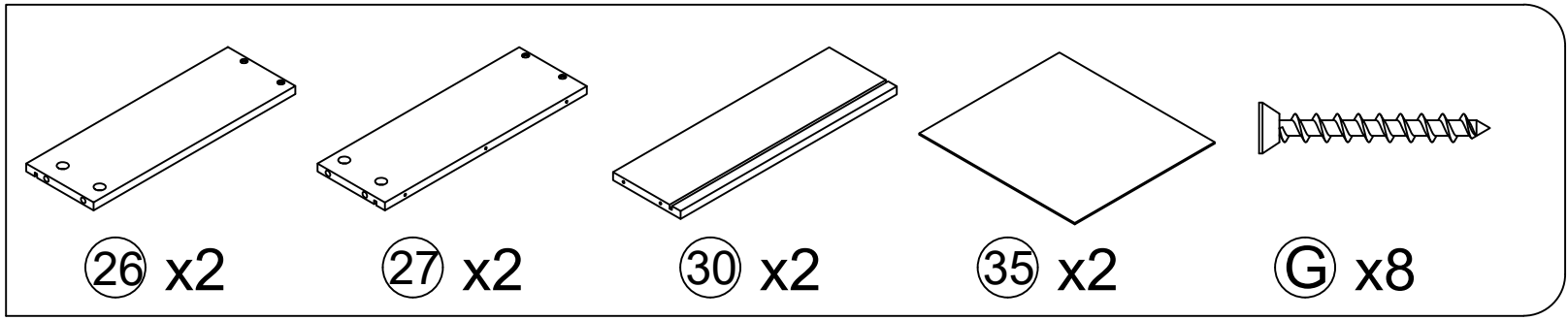

Please note that the panel groove should face inward and pay attention to the direction of each part during installation. Do not reverse the direction.

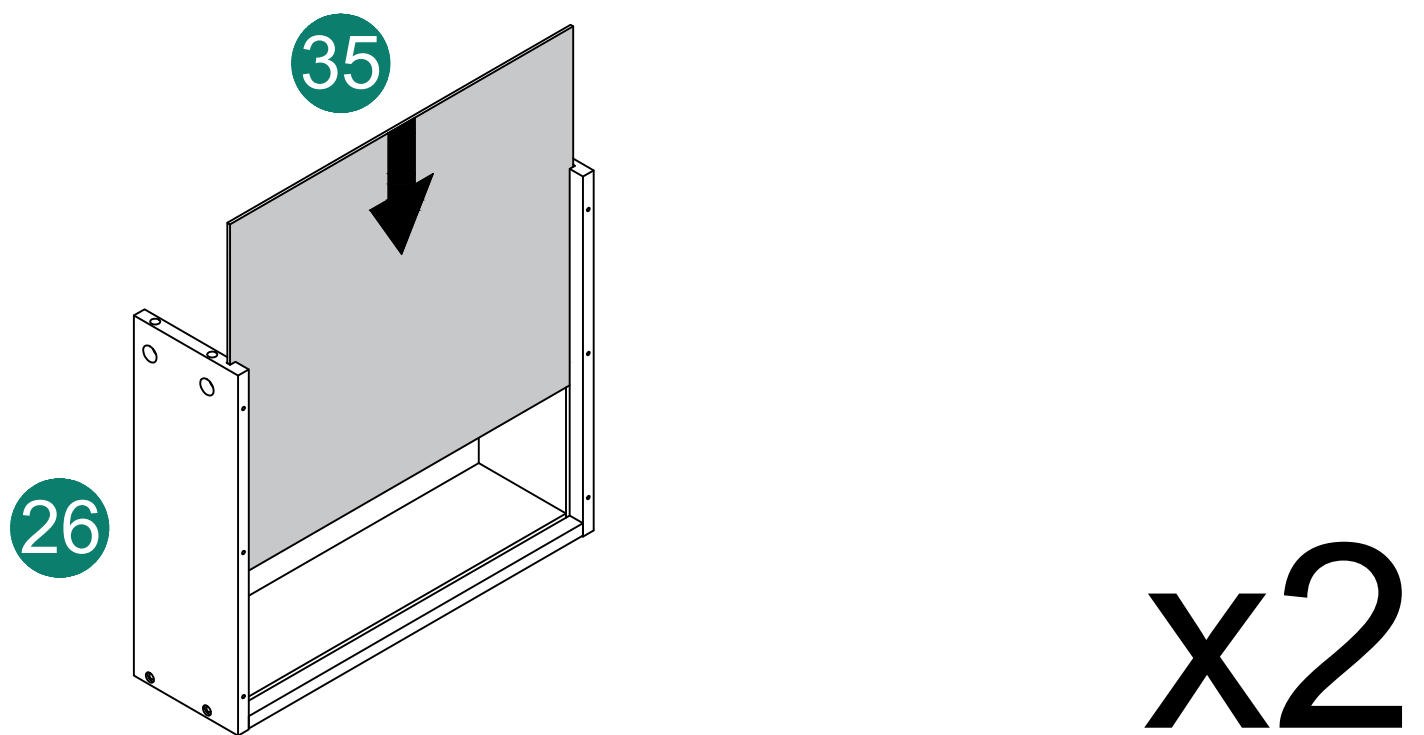
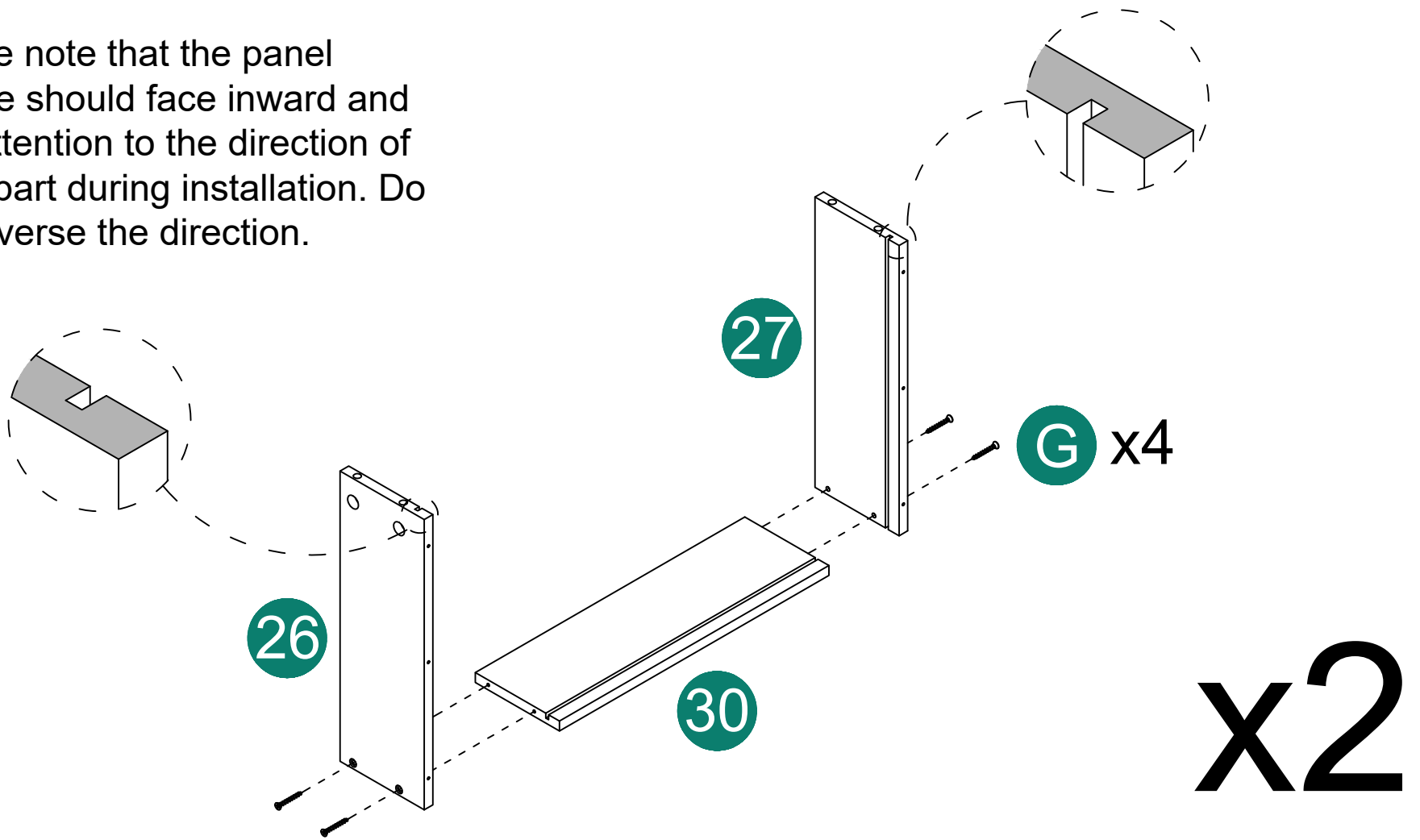

34

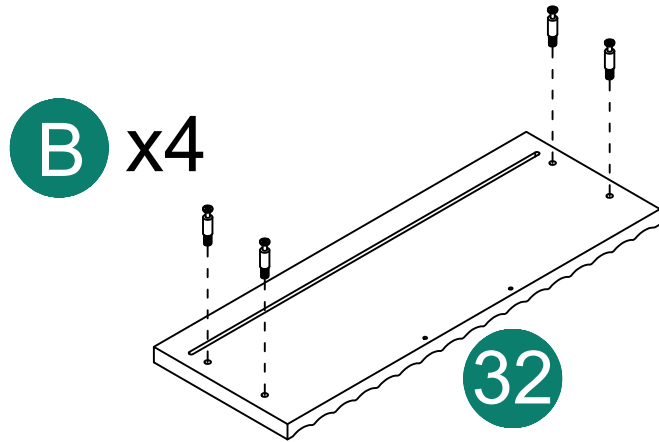
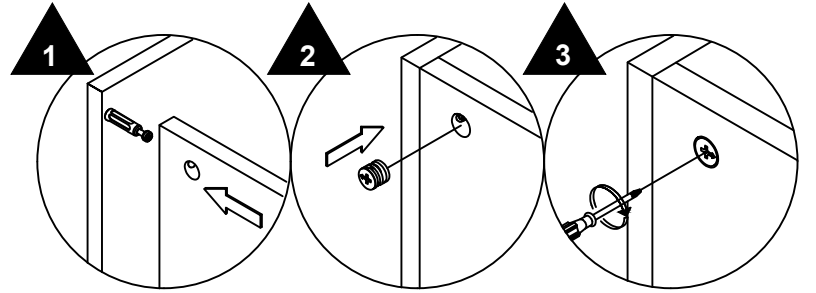
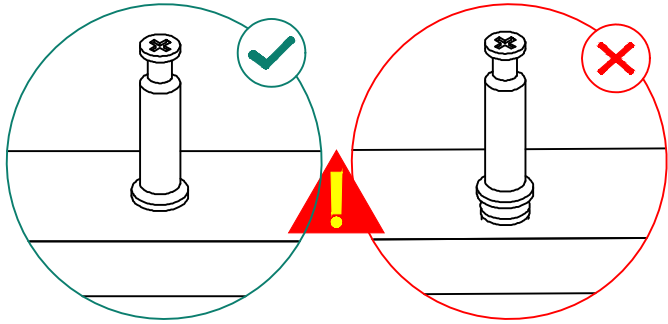
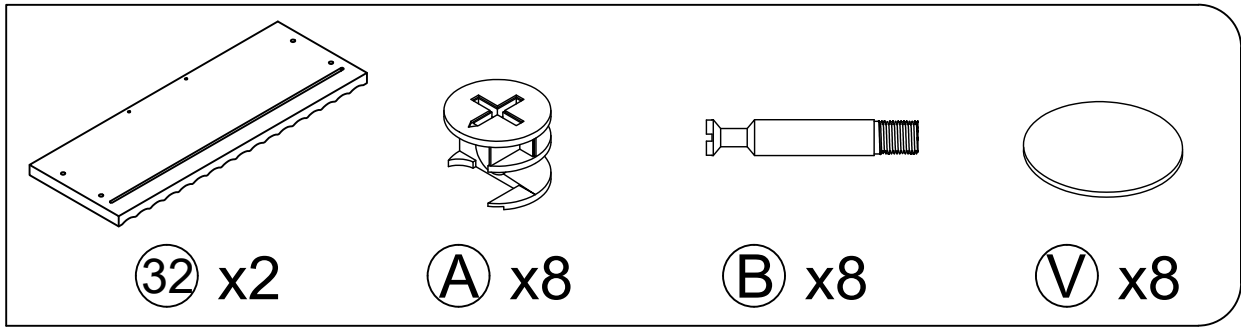

x2

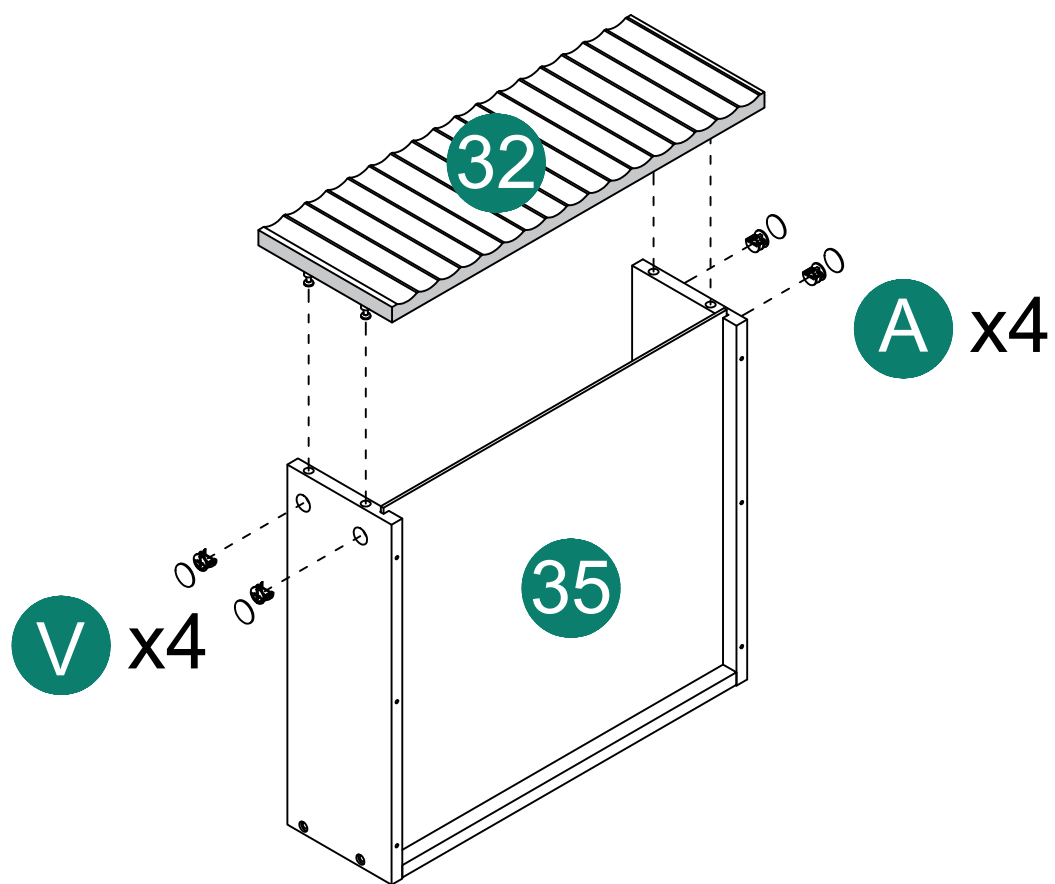

x2

35

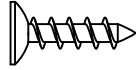
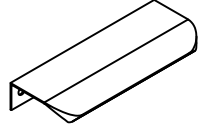
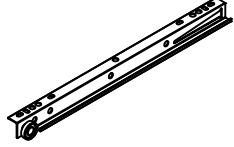
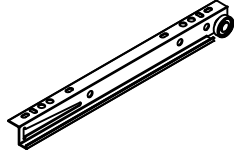
-  **E** x16
-  **H** x2
-  **K-DL** x2
-  **K-DR** x2

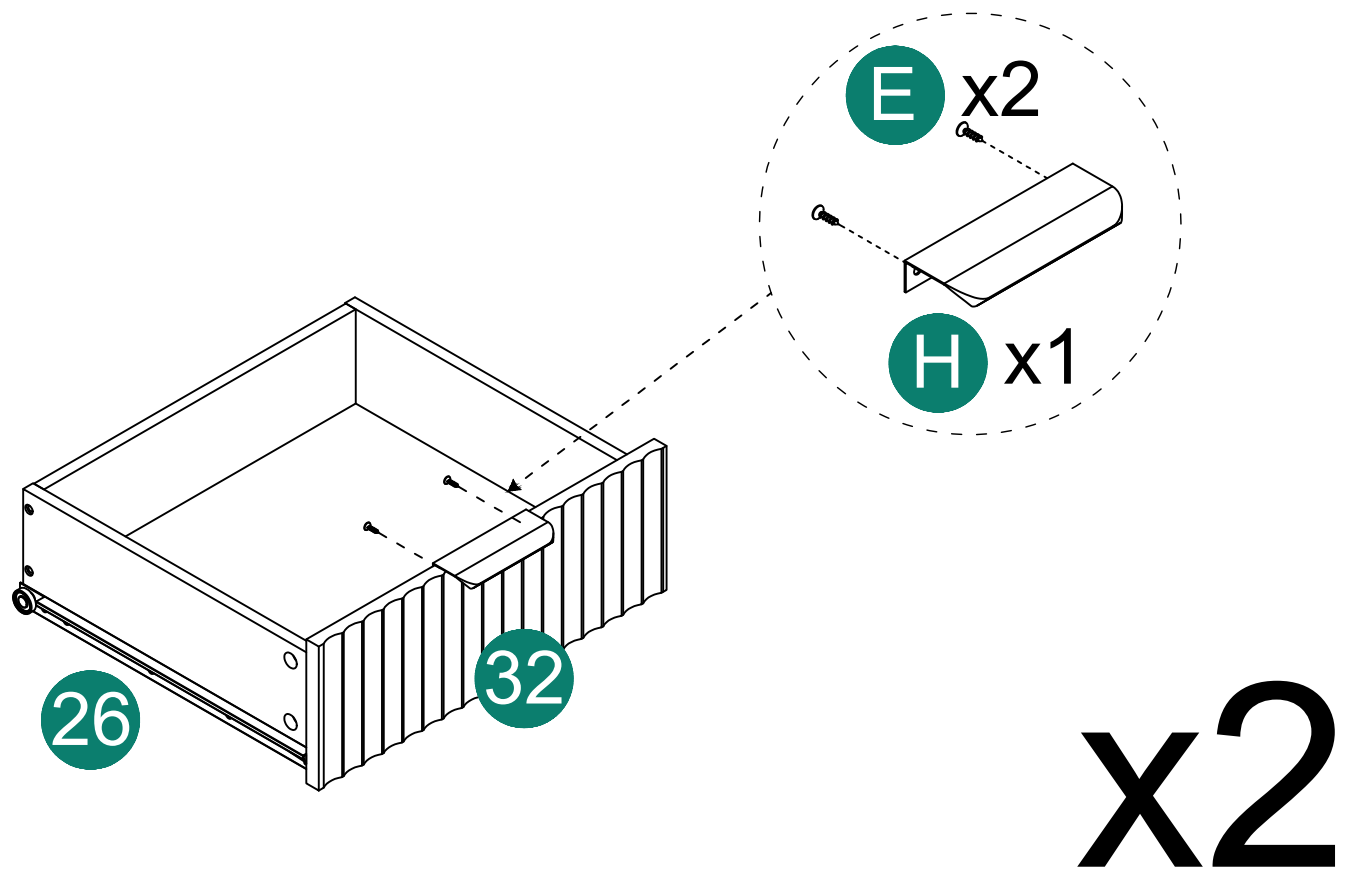
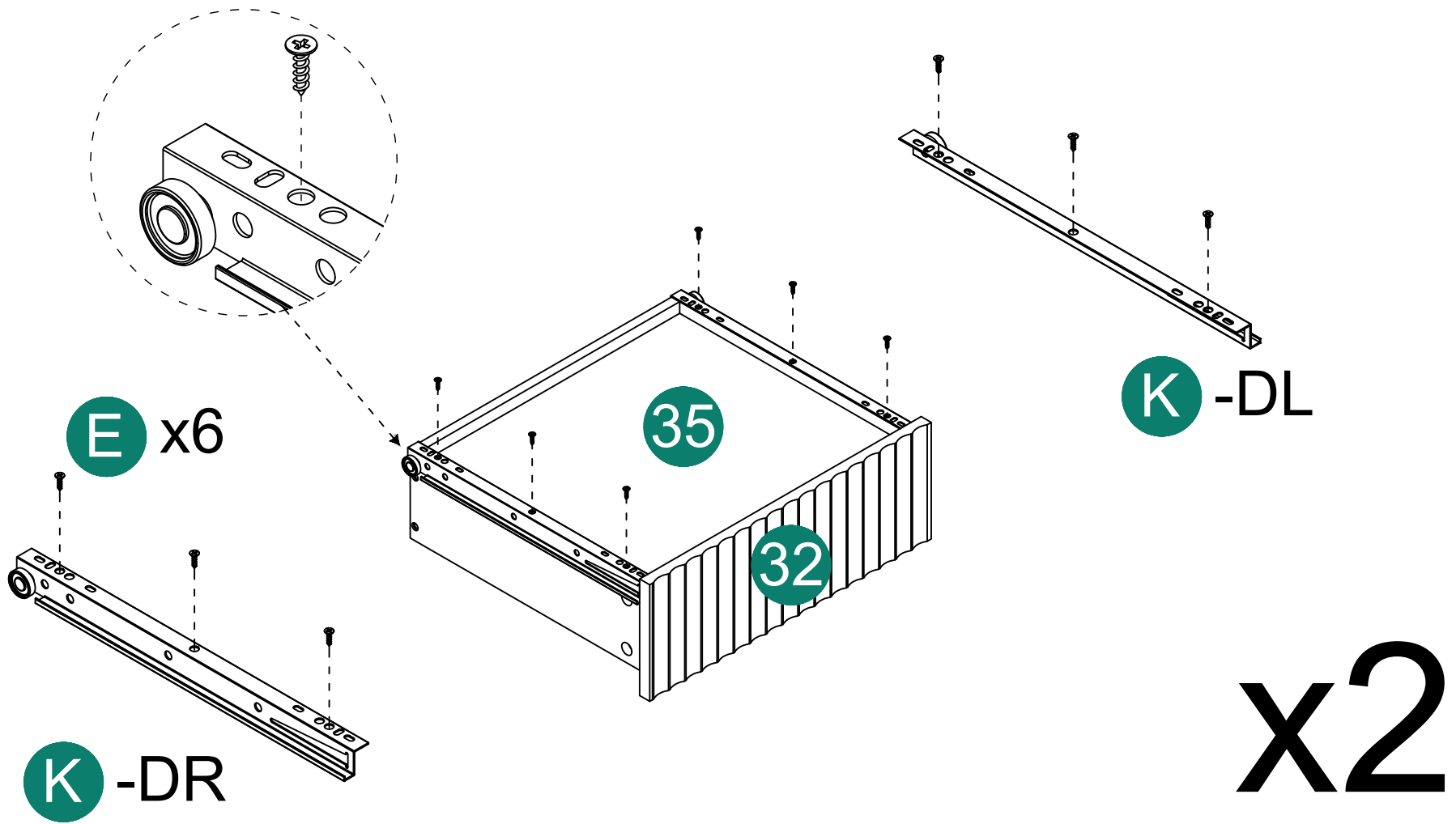

36

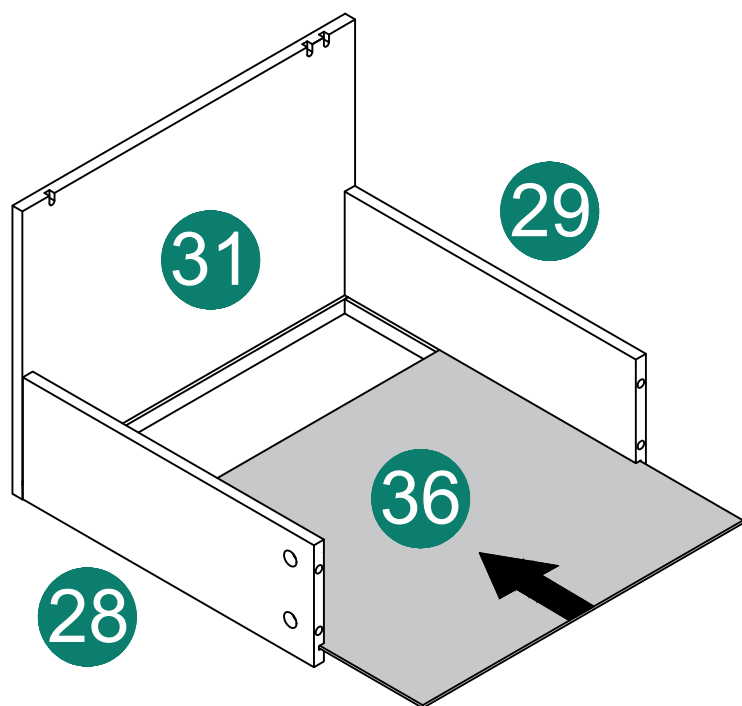
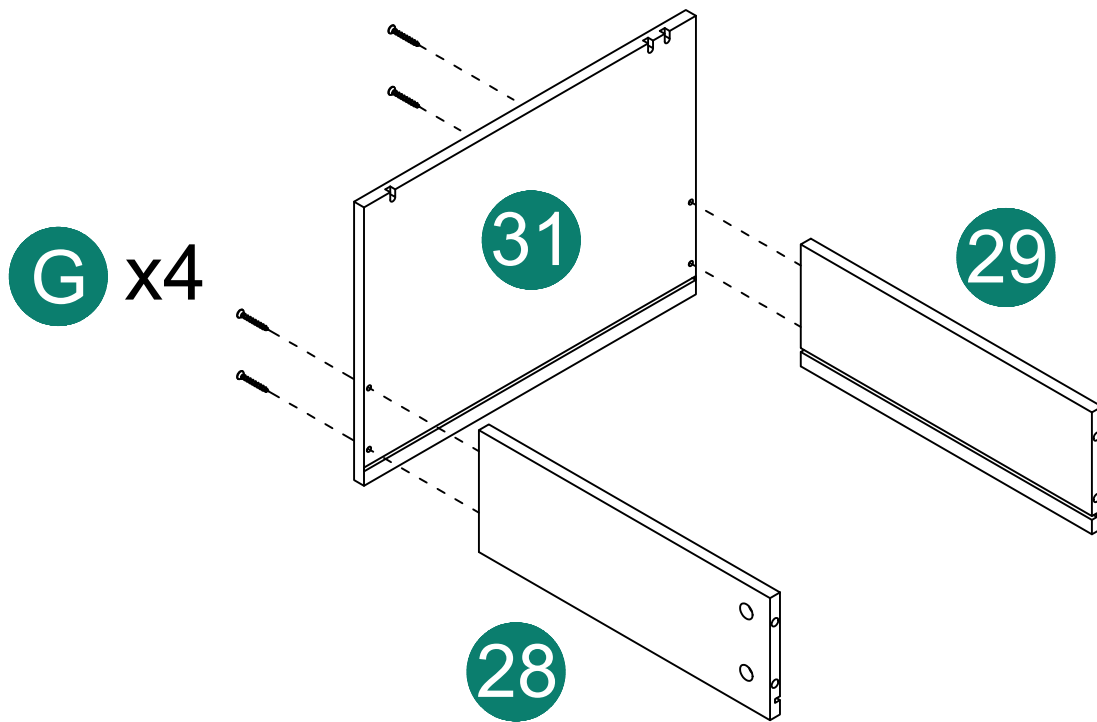
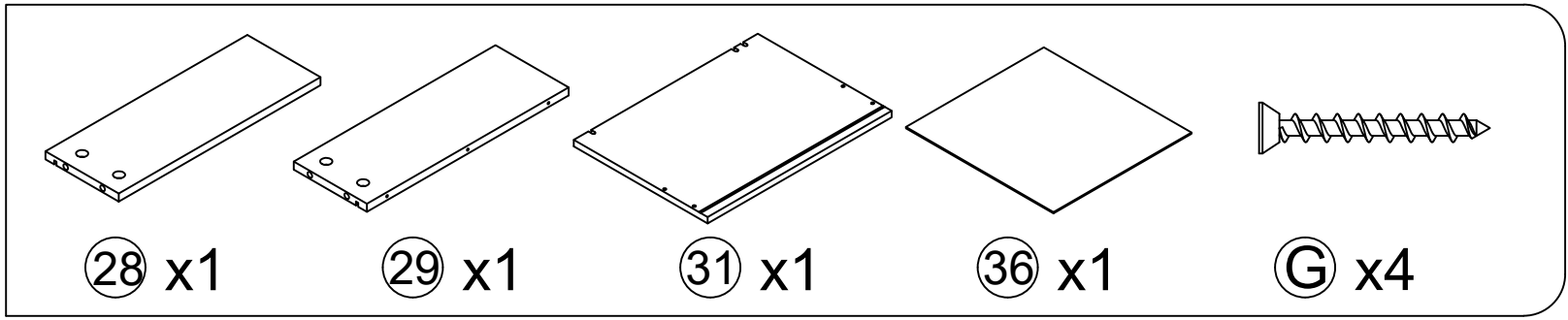

37

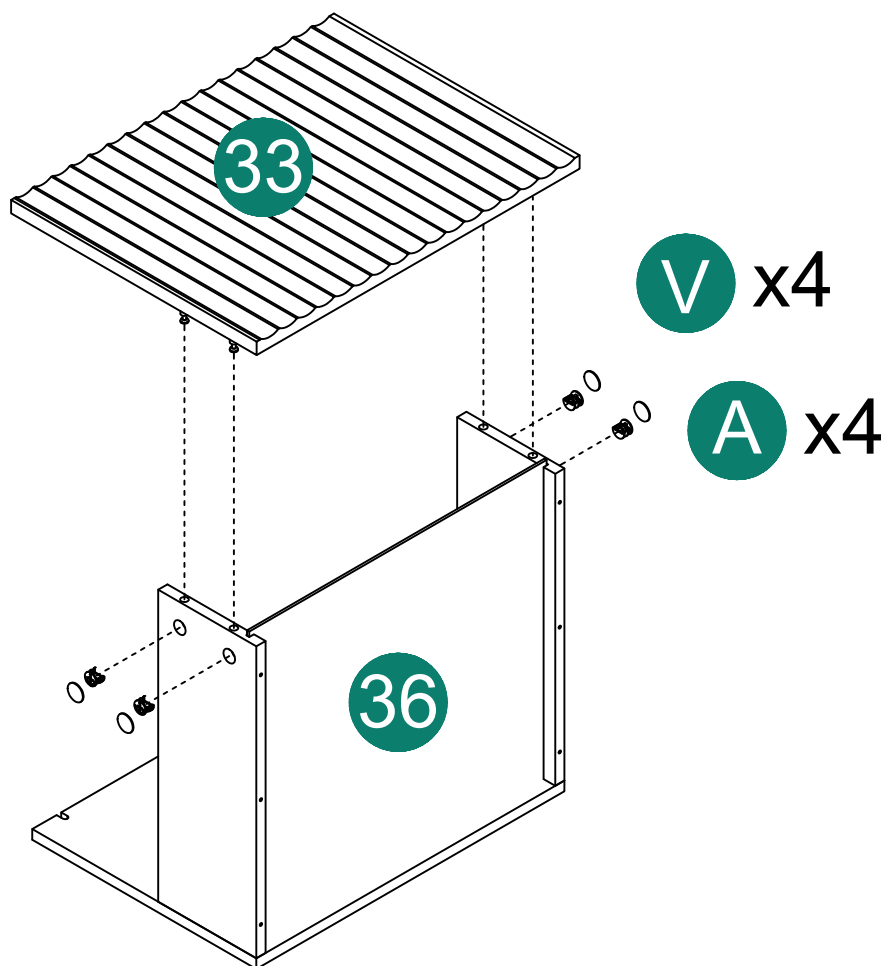
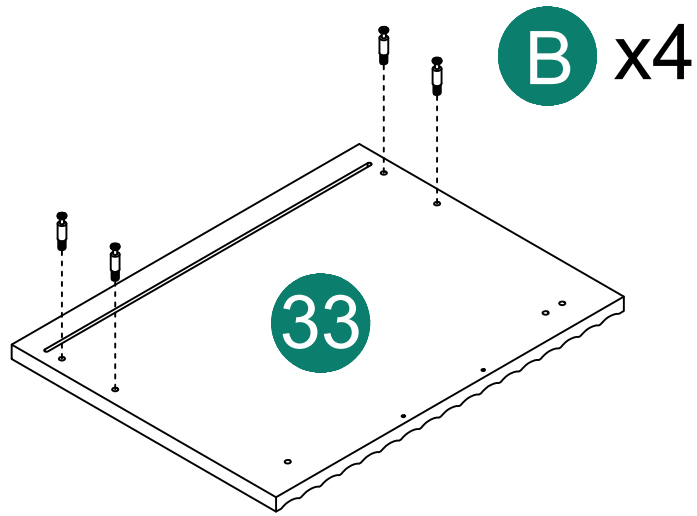
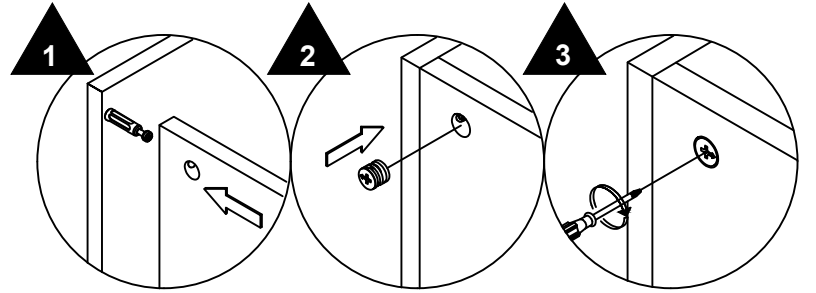
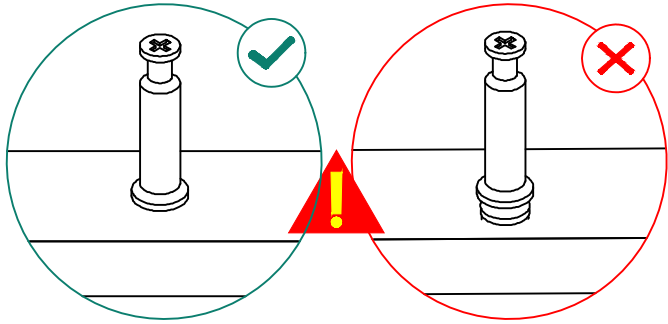
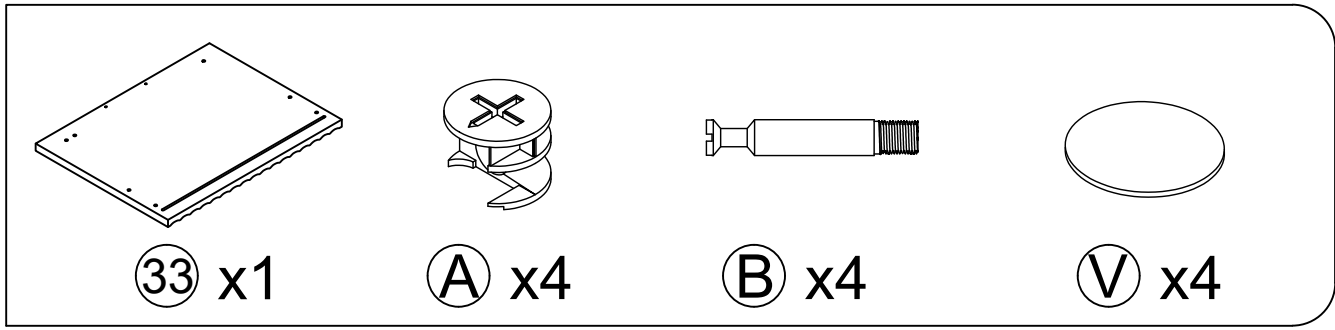

38

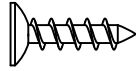
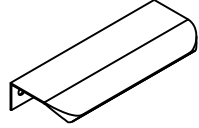
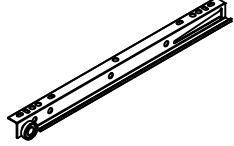
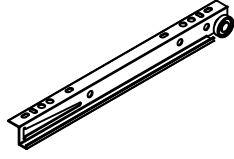
			
E x8	H x1	K-DL x1	K-DR x1

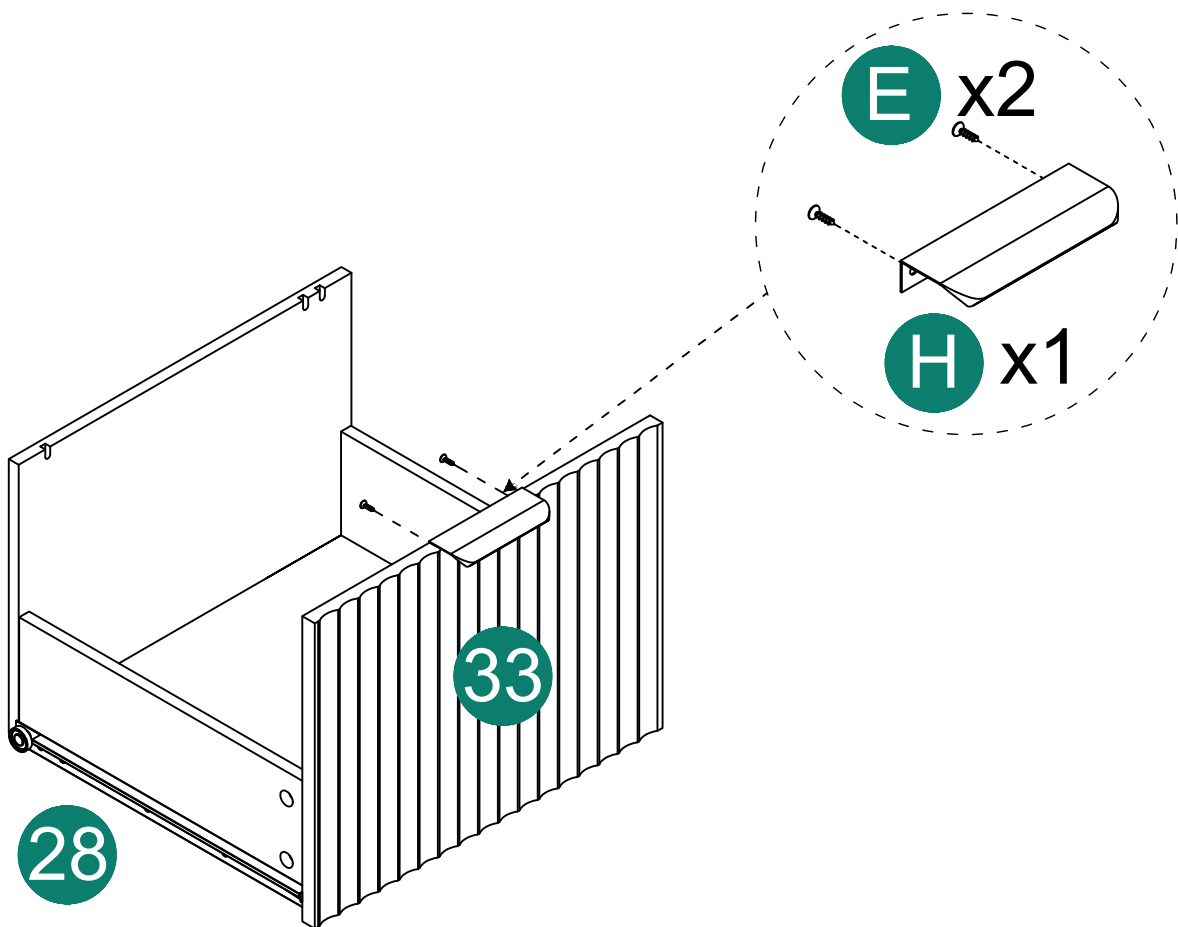
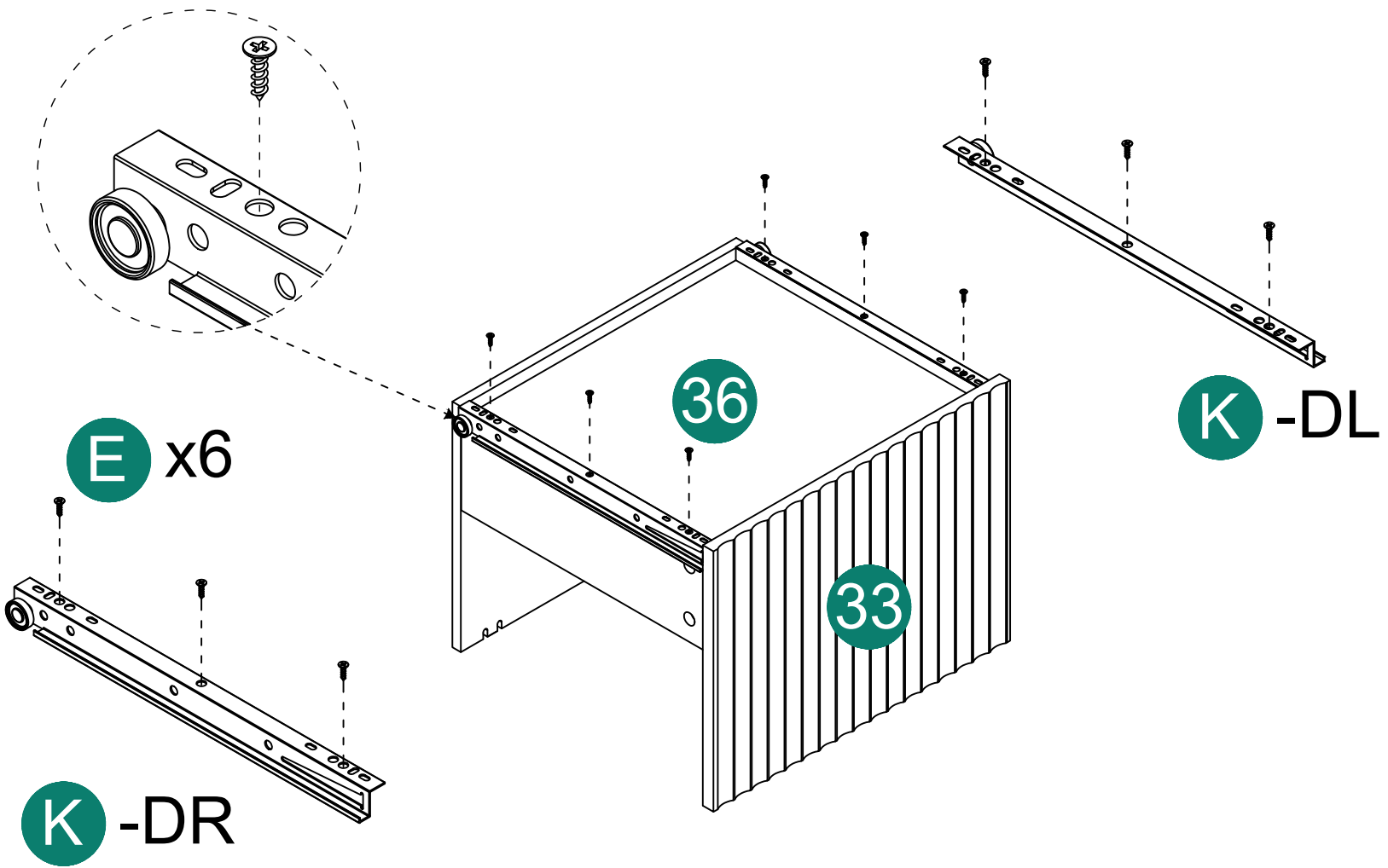

39

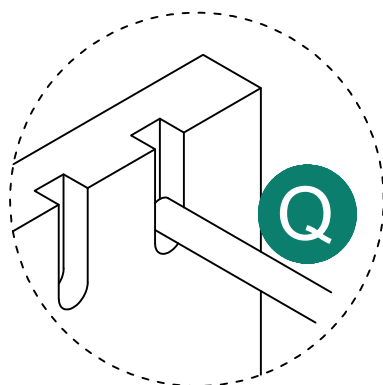
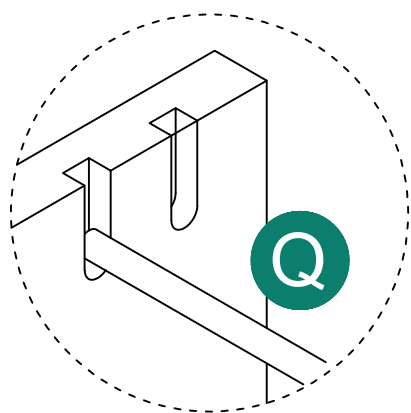
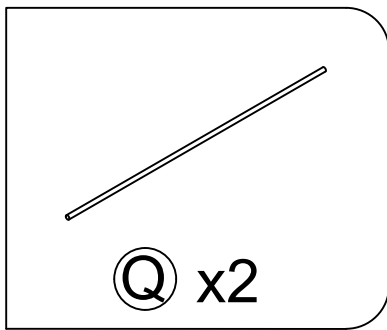

you can place A4 size or letter size folders when install stainless steel tubes as shown.

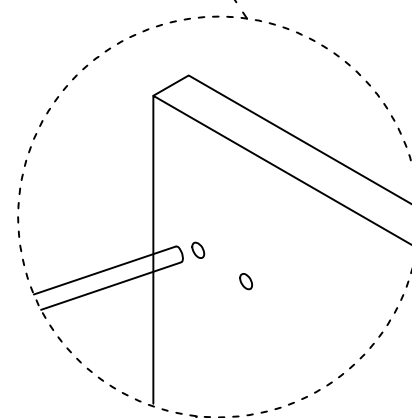
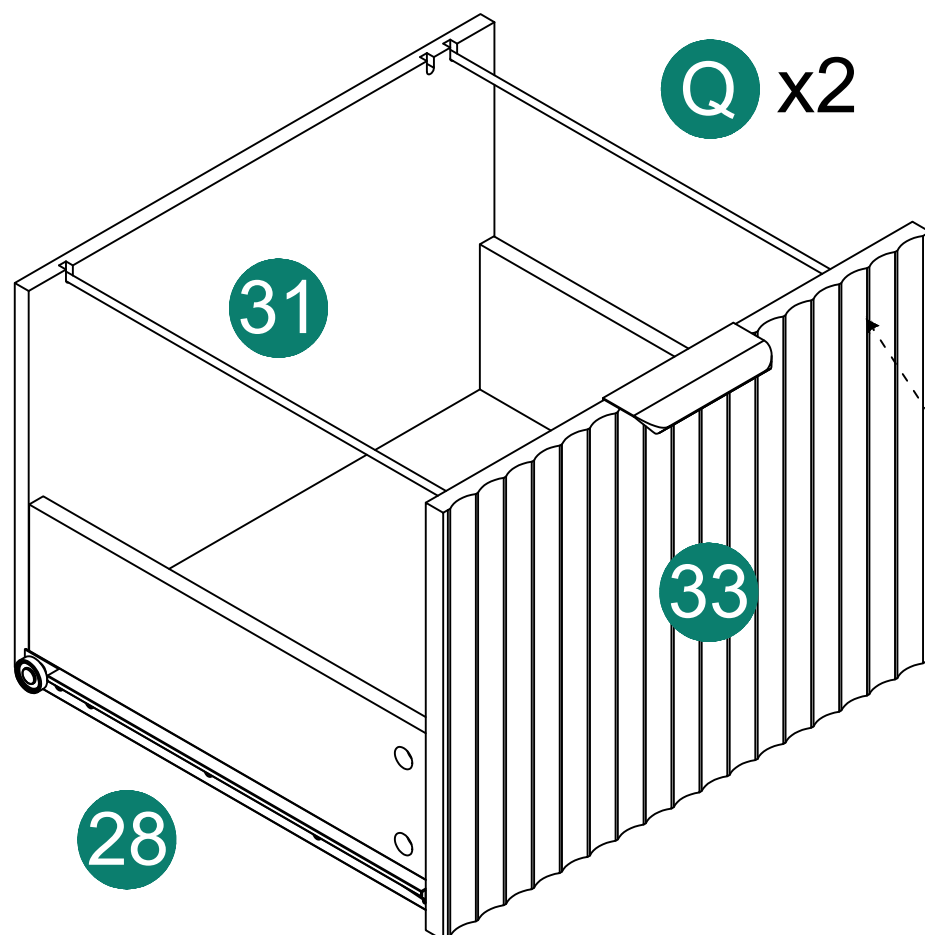

Insert the stainless steel tube into the hole at an angle.

40

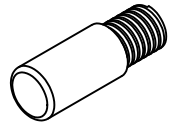

⊙ x1

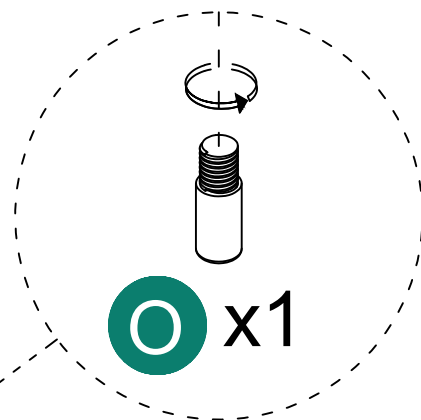

Align the pre-buried hole of 2 plates, rotate and screw in

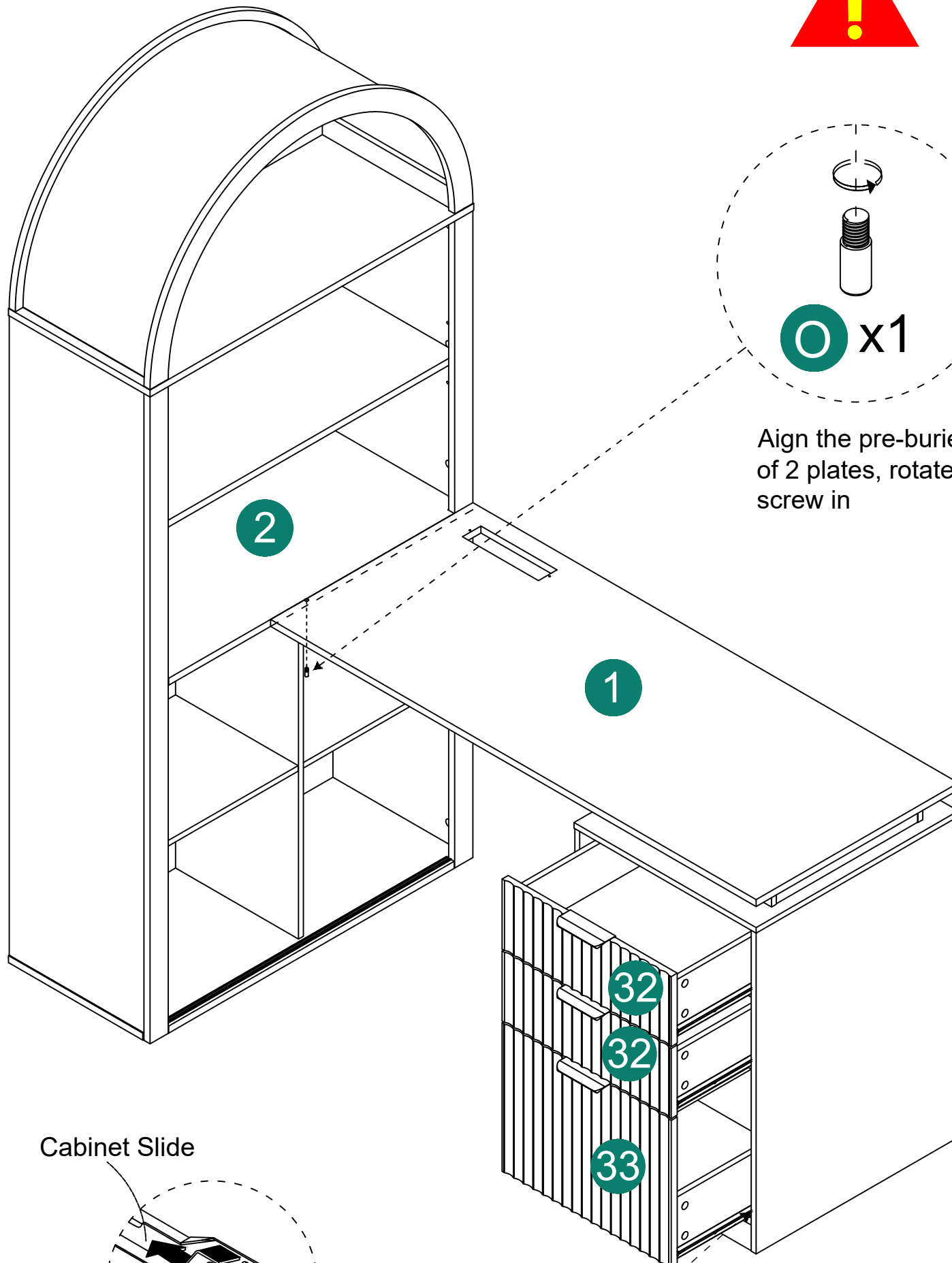

Cabinet Slide

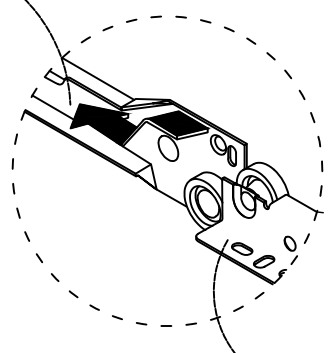

Drawer Slide

41

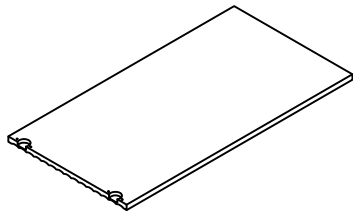

34 x1

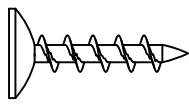

F x4

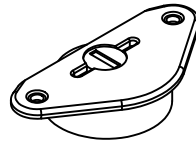

N x2

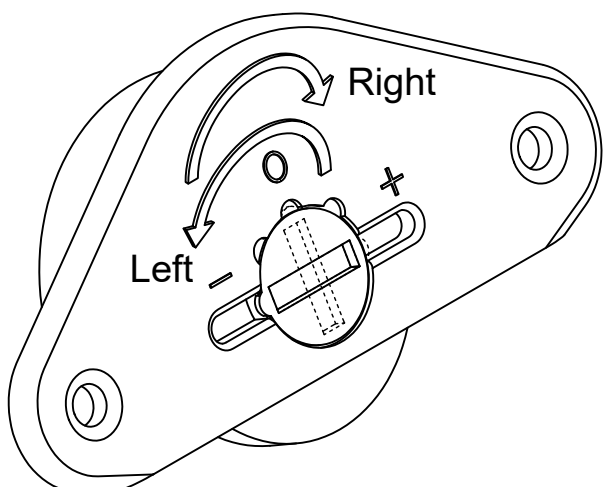
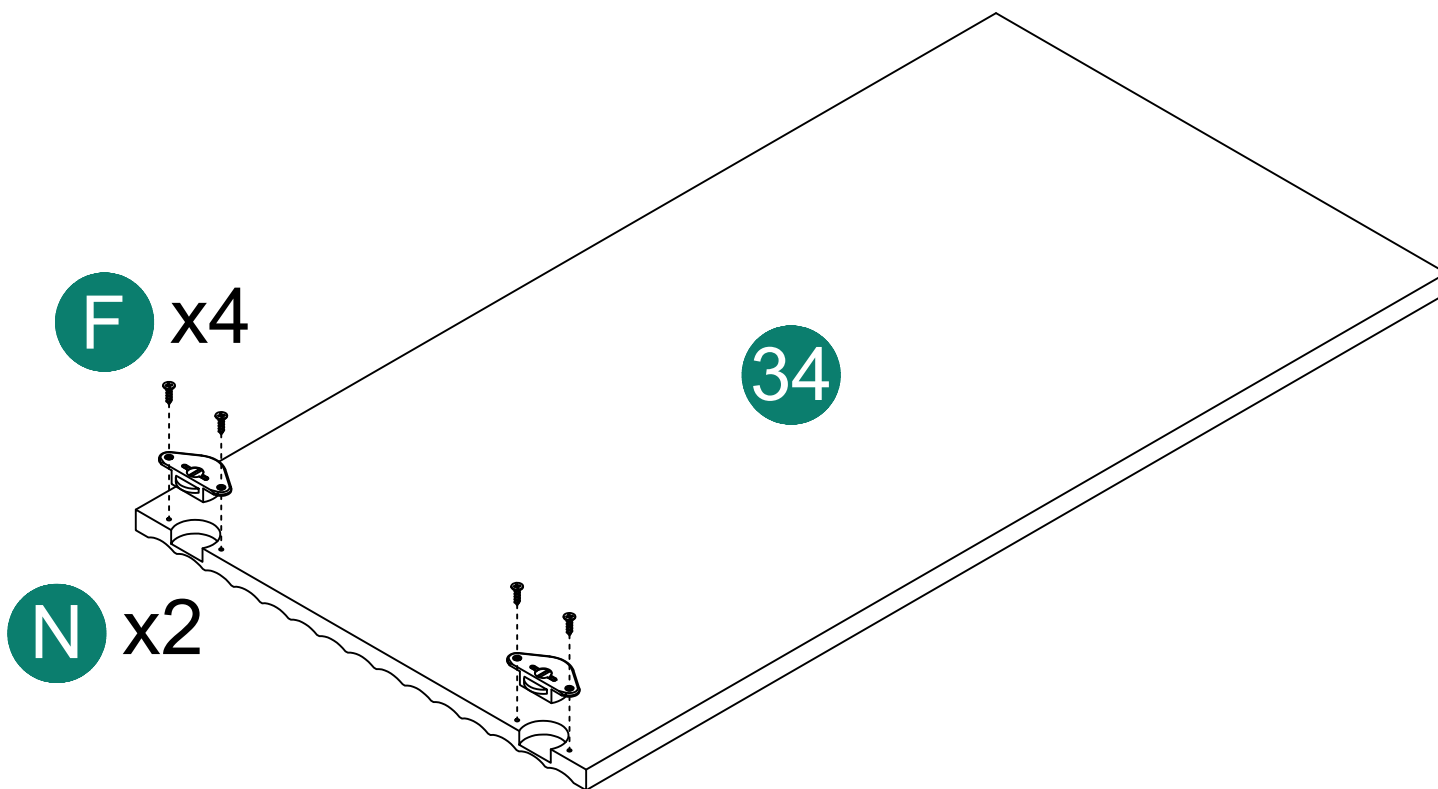

When installing the door, turn the pulley screw to the right if it is loose. If it is too tight, turn the pulley screw to the left until it is smooth

42

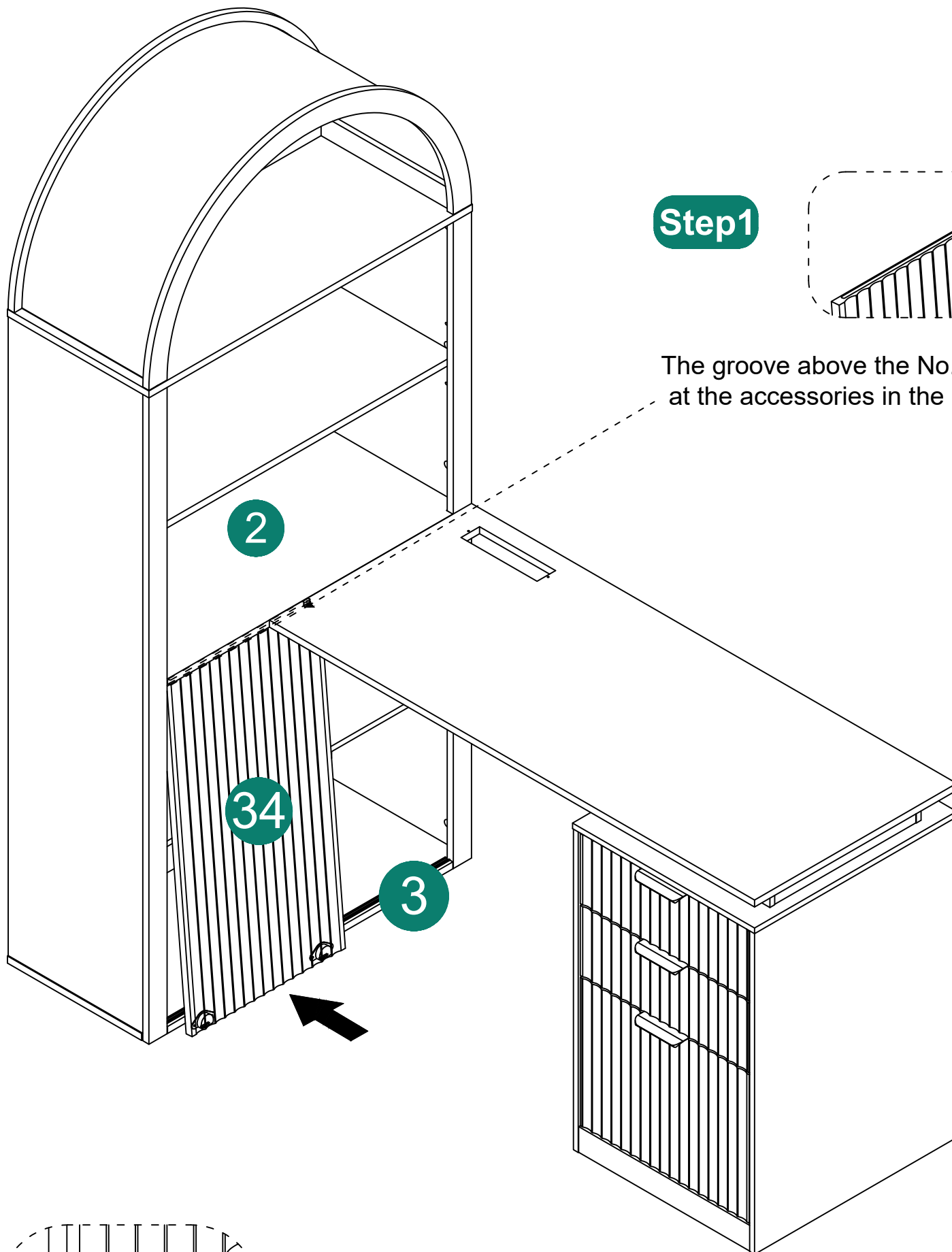

Step1

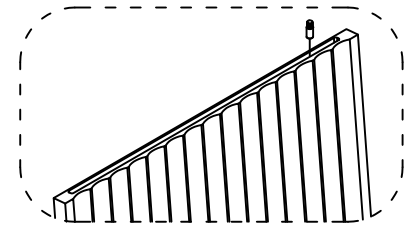

The groove above the No. 34 plate is aimed at the accessories in the No. 2 plate O

Step2

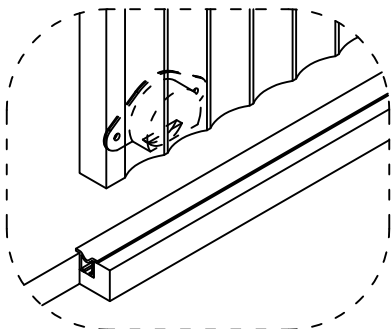

Push the bottom of the No. 34 plate inward, so that the accessories below it are stuck in the v-slot of the No. 3 plate, and the installation is completed.

43

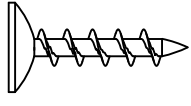

F x2

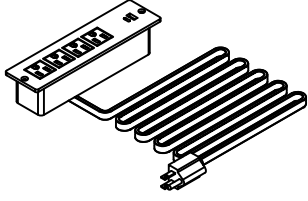

P x1

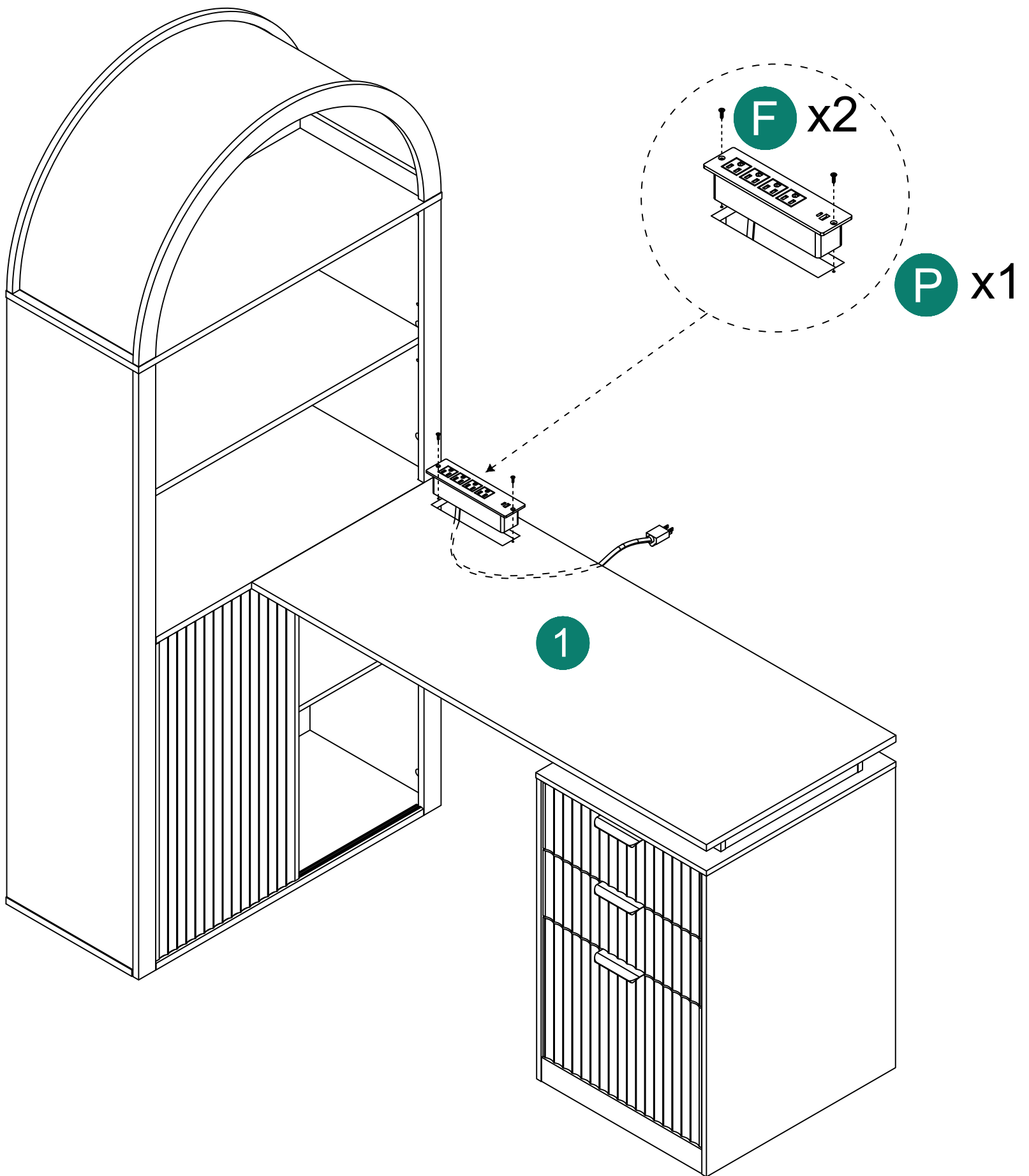

44

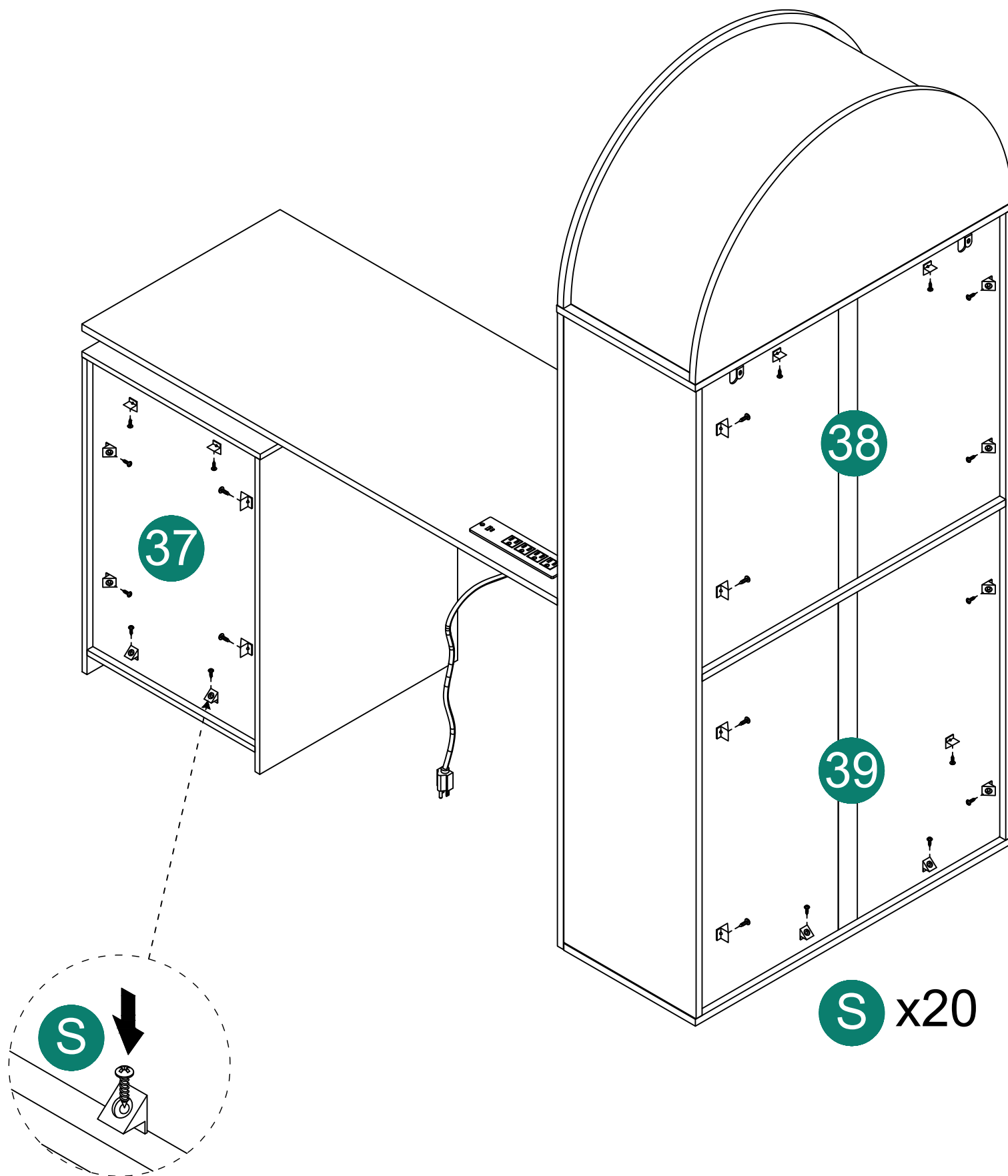
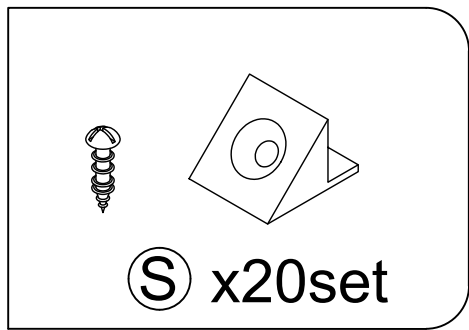

Insert the plastic buckle into the back plate slot, screw through the hole in the plastic buckle and lock it in place.

45

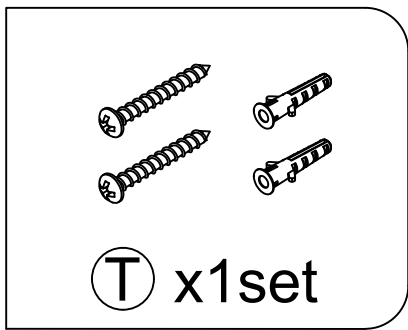

NOTE: The tipping restraint hardware included is for wooden stud wall construction. It must be attached to a wall stud. Depending upon your wall construction different anchor hardware may be required. Please contact your local hardware store for assistance. Young children can be seriously injured by tipping furniture. You must install the tipping restraint hardware with the unit to prevent the unit from tipping, causing any accidents or damage. The tipping restraints are intended only as a deterrent and are not a substitute for proper adult supervision. The tipping restraints are not earthquake restraints. If you wish to add the extra security of earthquake restraints, they must be purchased and installed separately.



Install the tipping restraint hardware

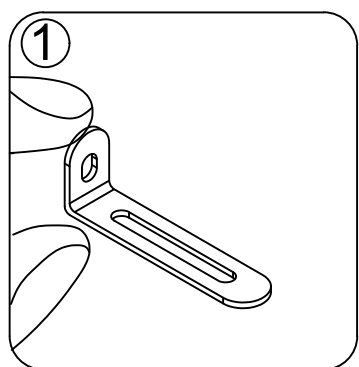

1. make mark on the wall

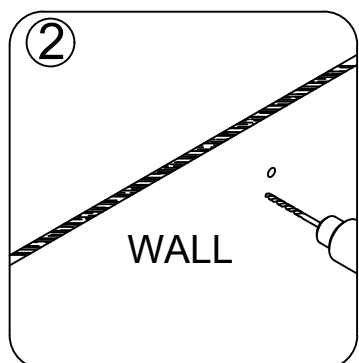

2. drill one Ø6 holes on the wall

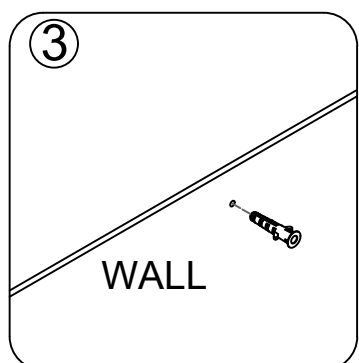

3. put one anchors in the holes

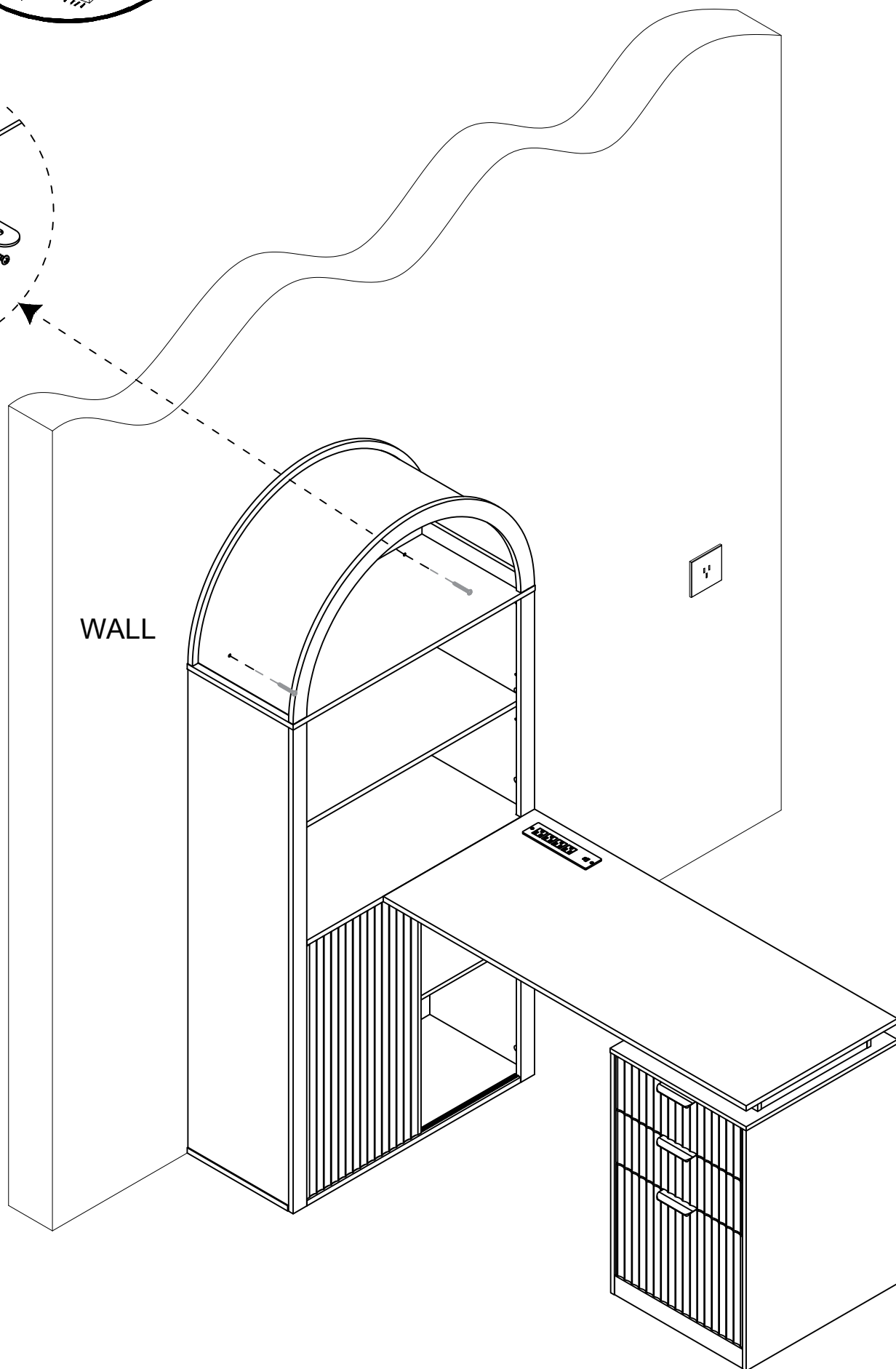
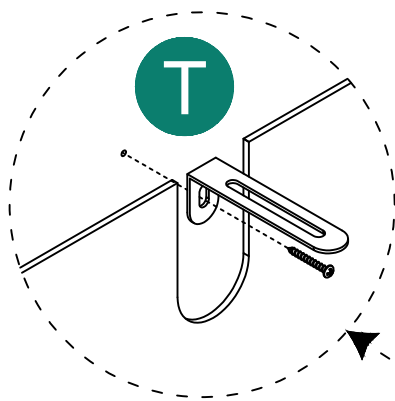

HELP CENTER



Inquiry



Assembly issue



Missing parts

If you encounter any difficulties during assembly, please contact us.

Wenn Sie während der Montage auf Schwierigkeiten stoßen, kontaktieren Sie uns bitte.

Si vous rencontrez des difficultés lors du montage, veuillez nous contacter.

Se incontri difficoltà durante il montaggio, ti preghiamo di contattarci.

Si encuentras alguna dificultad durante el ensamblaje, por favor contáctanos.

DISCLAIMER

Manufacturer and seller expressly disclaim any and all liability for personal injury, property damage or loss, whether direct, indirect, or incidental, resulting from the incorrect attachment, improper use, inadequate maintenance, unapproved modification, or neglect of this product.

Der Hersteller und Verkäufer lehnen ausdrücklich jegliche Haftung für Personenschäden, Sachschäden oder Verluste ab, egal ob direkt, indirekt oder zufällig, die durch falsche Anbringung, unsachgemäßen Gebrauch, unzureichende Wartung, nicht genehmigte Änderungen oder Vernachlässigung dieses Produkts entstehen.

El fabricante y vendedor renuncian expresamente a toda responsabilidad por lesiones personales, daños materiales o pérdidas, ya sean directos, indirectos o incidentales, derivados de la incorrecta colocación, uso inadecuado, mantenimiento insuficiente, modificación no aprobada o negligencia de este producto.

Il produttore e il venditore declinano espressamente ogni responsabilità per lesioni personali, danni materiali o perdite, dirette, indirette o incidentali, derivanti dall'errato fissaggio, uso improprio, manutenzione inadeguata, modifica non autorizzata o negligenza di questo prodotto.

Le fabricant et le vendeur déclinent expressément toute responsabilité en cas de blessures corporelles, de dommages matériels ou de pertes, qu'ils soient directs, indirects ou accessoires, résultant de la fixation incorrecte, de l'utilisation inappropriée, de l'entretien insuffisant, de la modification non approuvée ou de la négligence de ce produit.