

**M2-9020/M2-9021**

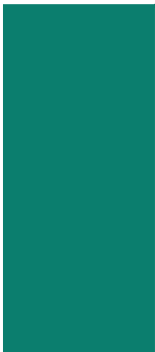
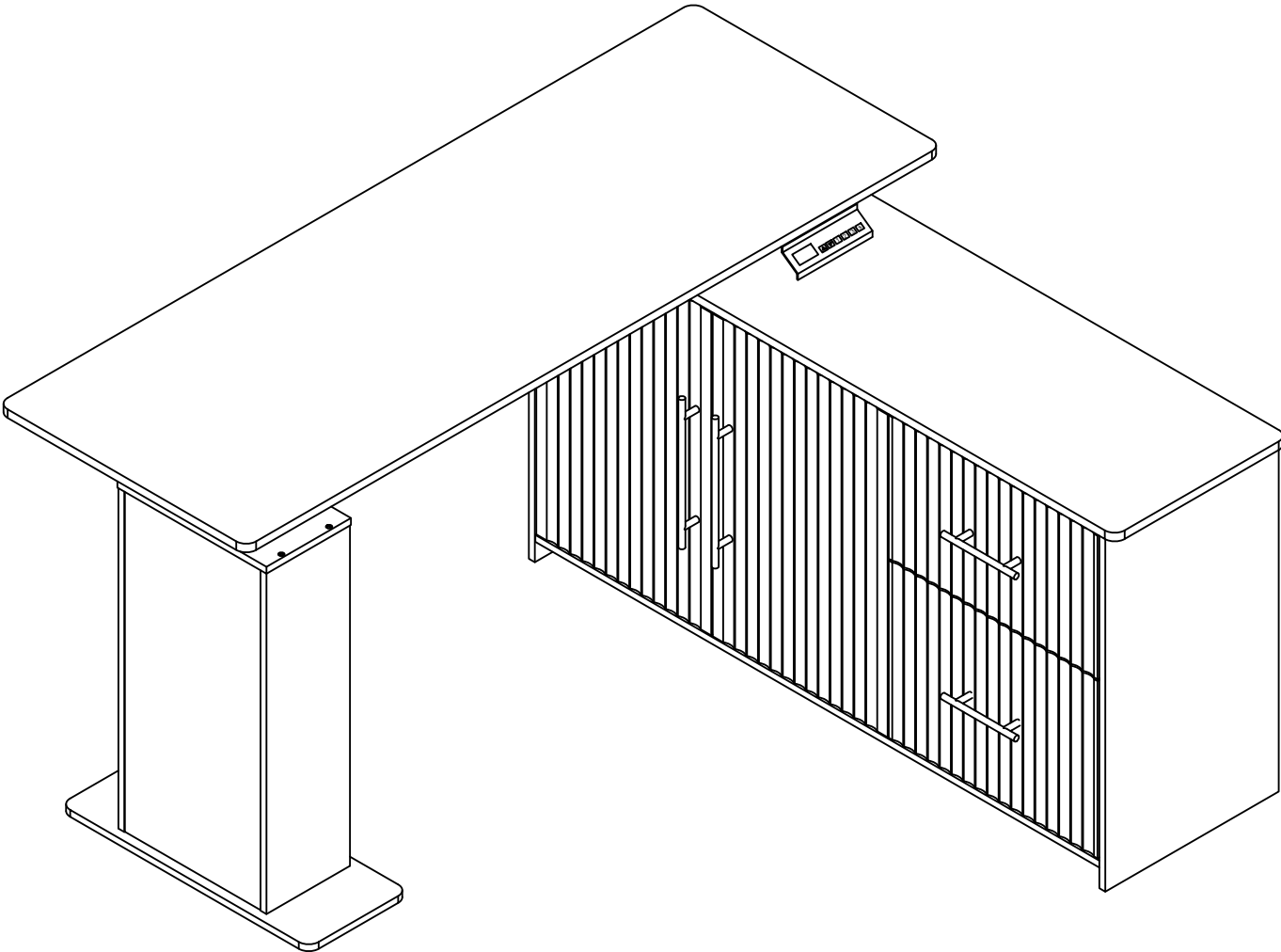

**ASSEMBLY  
INSTRUCTIONS**

# NOTICE

IMPORTANT, RETAIN FOR FUTURE REFERENCE: READ CAREFULLY  
WICHTIG, FÜR SPÄTERE NACHSCHLAGE AUFBEWAHREN: SORGFÄLTIG LESEN  
IMPORTANTE, GUARDAR PARA REFERENCIA FUTURA: LEER ATENTAMENTE  
IMPORTANTE, CONSERVARE PER RIFERIMENTI FUTURI: LEGGERE ATTENTAMENTE  
IMPORTANT, À CONSERVER POUR RÉFÉRENCE FUTURE : LIRE ATTENTIVEMENT

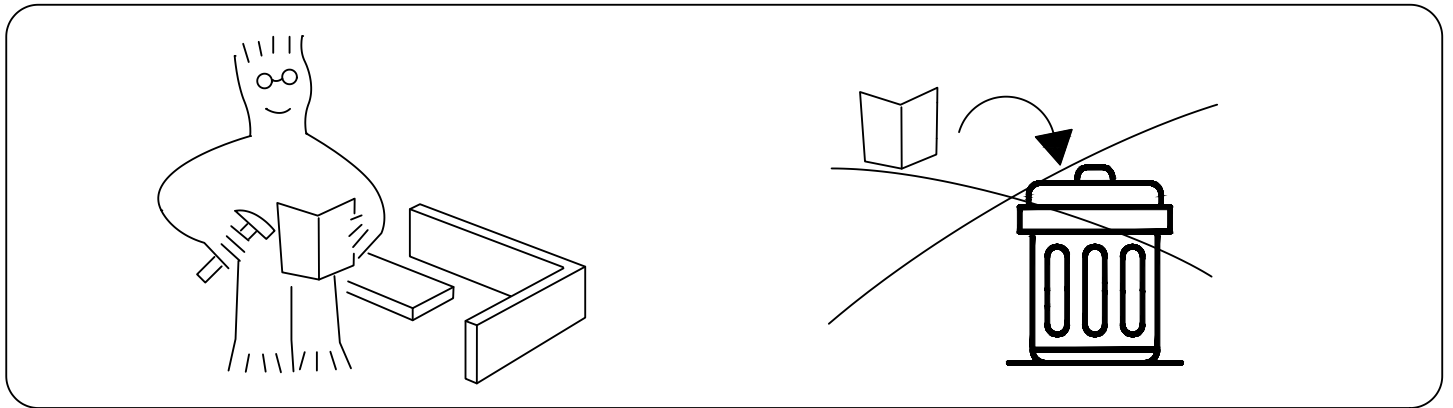

Assemble on a flat, clean and soft surface.  
Auf einer flachen, sauberen und weichen Oberfläche zusammenbauen.  
Assembler sur une surface plate, propre et douce.  
Assemblare su una superficie piatta, pulita e morbida.  
Ensamblar sobre una superficie plana, limpia y suave.

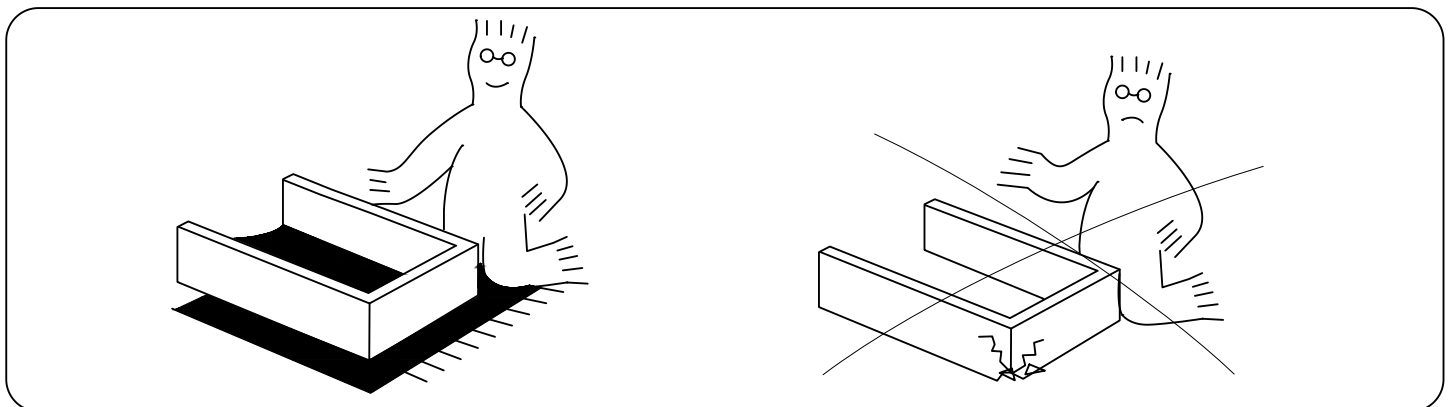

Professional installation is highly recommended.  
Eine professionelle Installation wird dringend empfohlen.  
Une installation professionnelle est fortement recommandée.  
Si raccomanda vivamente l'installazione professionale.  
Se recomienda altamente la instalación profesional.



Periodically Check That All Components Are Tightly Secured.  
Überprüfen Sie Regelmäßig, Dass Alle Komponenten Fest Gesichert Sind.  
Vérifiez Périodiquement Que Tous Les Composants Sont Bien Fixés.  
Controllare Periodicamente Che Tutti I Componenti Siano Ben Fissati.  
Verifique Periódicamente Que Todos Los Componentes Estén Bien Asegurados.

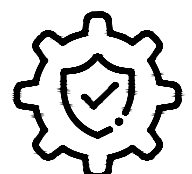

It is recommended that multiple people assemble this product.  
 Es wird empfohlen, dass mehrere Personen dieses Produkt zusammenbauen.  
 Il est recommandé que plusieurs personnes assemblent ce produit.  
 Si raccomanda che più persone assemblino questo prodotto.  
 Se recomienda que varias personas ensamblen este producto.

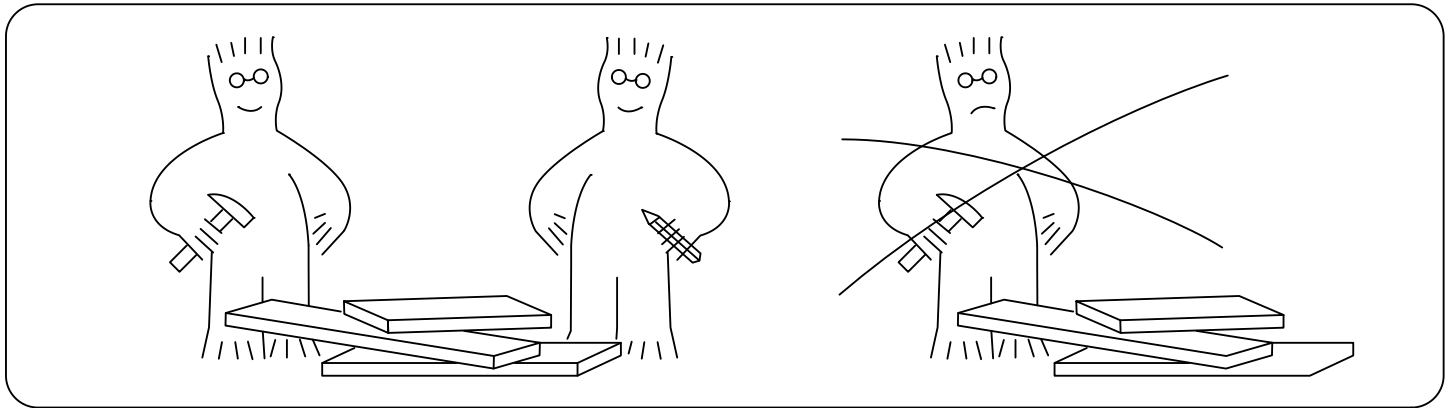

Serious or fatal crushing injuries can occur from furniture tip-over. Always secure this furniture to the wall using tip-over restraints.

Schwere oder tödliche Quetschverletzungen können durch das Umkippen von Möbeln verursacht werden. Sichern Sie diese Möbel immer mit Kipp-Sicherungen an der Wand.

Des blessures graves ou mortelles par écrasement peuvent survenir en cas de basculement de meubles. Fixez toujours ces meubles au mur à l'aide de dispositifs anti-basculement.

Lesioni gravi o mortali da schiacciamento possono verificarsi a causa del ribaltamento dei mobili. Fissare sempre questi mobili alla parete utilizzando i sistemi di blocco anti-ribaltamento.

Pueden ocurrir lesiones graves o fatales por aplastamiento debido al volcamiento de muebles. Siempre asegure este mueble a la pared utilizando dispositivos anti-vuelco.

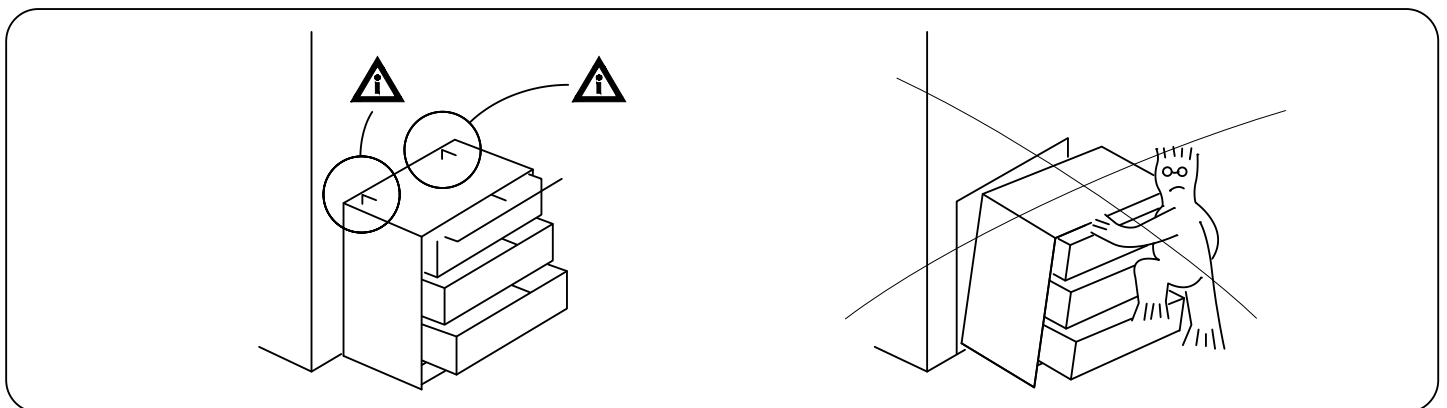

Please have the following auxiliary tools ready:

Bitte haben Sie die folgenden Hilfswerkzeuge bereit:

Veillez avoir les outils auxiliaires suivants à portée de main:

Si prega di avere pronti i seguenti strumenti ausiliari:

Por favor, tenga listos las siguientes herramientas auxiliares:

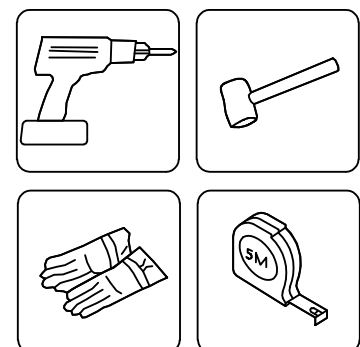

USING CAM LOCK AND QUICKFIT  
 VERWENDUNG VON NOCKENSCHL OSS UND QUICKFIT  
 UTILISATION DE SERRURE À CAME ET QUICKFIT  
 USO DISERRATURA A LEVA E QUICKFIT  
 USANDO EL CIERRE DE LEVAY QUICKFIT

Tighten QuickFit until the shoulder is flush with the panel. Do not overtighten or undertighten.  
 Ziehen Sie den Quickfit an, bis die Schulter bündig mit der Platte ist. Nicht zu fest oder zu locker anziehen.  
 Serrez le quickfit jusqu'à ce que l'épaulement soit affleurant avec le panneau. Ne serrez pas trop ou trop peu.  
 Stringere il quickfit fino a quando la spalla è a filo con il pannello. Non stringere troppo o troppo poco.  
 Apriete el quickfit hasta que el hombro esté al ras con el panel. No apriete demasiado ni demasiado poco.

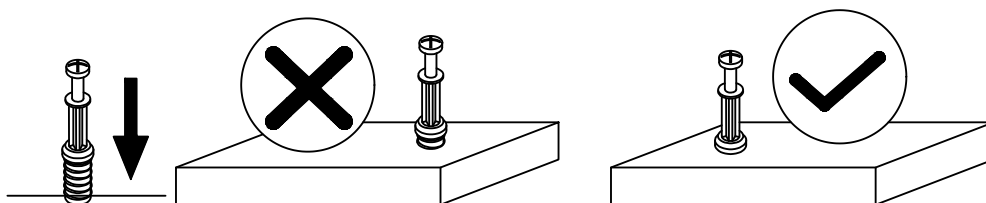



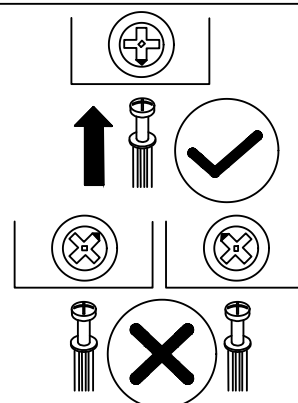

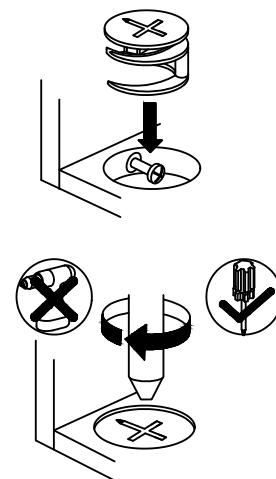

When fitting the cam lock, ensure the starting position is correct before inserting the connecting QuickFit.  
 Stellen Sie beim Einbau des nockenschloss sicher, dass die Startposition korrekt ist, bevor Sie den verbindenden Quickfit einsetzen.  
 Lors de la pose du serrure à came, assurez-vous que la position de départ est correcte avant d'insérer le quickfit de connexion.  
 Quando si monta il serratura a leva, assicurarsi che la posizione di partenza sia corretta prima di inserire il quickfit di collegamento.  
 Al instalar el cierre de leva, asegúrese de que la posición inicial sea correcta antes de insertar el quickfit de conexión.



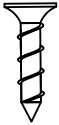

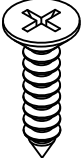
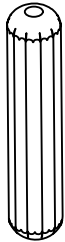



The QuickFit head should be in the center of the cam lock when the two panels are joined. The cam lock should be inserted before the QuickFit. Turn the cam lock clockwise to tighten.  
 Der Quickfit-Kopf sollte sich in der Mitte des nockenschloss befinden, wenn die beiden Platten verbunden sind. Der nockenschloss sollte vor dem Quickfit eingesetzt werden. Drehen Sie den nockenschloss im Uhrzeigersinn, um ihn zu befestigen.  
 La tête du quickfit doit être au centre du serrure à came lorsque les deux panneaux sont assemblés. Le serrure à came doit être inséré avant le quickfit. Tournez le serrure à came dans le sens des aiguilles d'une montre pour le serrer.  
 La testa del quickfit dovrebbe essere al centro del serratura a leva quando i due pannelli sono uniti. Il serratura a leva deve essere inserito prima del quickfit. Ruotare il serratura a leva in senso orario per stringere.  
 La cabeza del quickfit debe estar en el centro del cam lock cuando los dos paneles estén unidos. El cierre de leva debe insertarse antes del quickfit. Gire el cierre de leva en sentido horario para apretar.



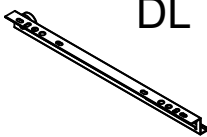

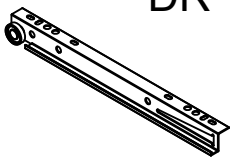

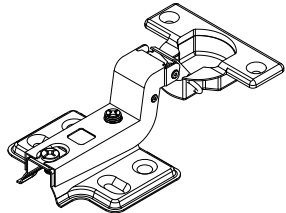

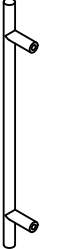
# PARTS

Item no. Nr. N °d article Articolo No. Artículo No	Reference Image Referenzbild Image de référence Immagine di riferimento Imagen de referencia	Qty Menge Qté. Qtà Cant.	Item no. Nr. N °d article Articolo No. Artículo No	Reference Image Referenzbild Image de référence Immagine di riferimento Imagen de referencia	Qty Menge Qté. Qtà Cant.
(A)	 Ø15X9.5mm	X41 +3	(E)	 Ø3.5X12mm	X40 +3
(B)	 Ø6.5X35mm	X41 +3	(F)	 Ø3.5X14mm	X2 +1
(C)	 Ø6X30mm	X32 +3	(G)	CL  L=250mm	X2
(D)	 Ø4X35mm	X26 +2	(G)	CR  L=250mm	X2

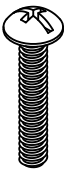
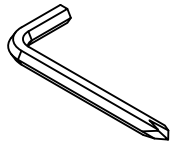
# PARTS

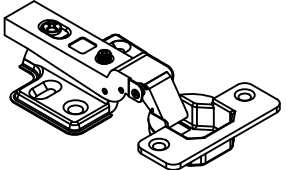
Item no. Nr. N° d article Articolo No. Artículo No	Reference Image Referenzbild Image de référence Immagine di riferimento Imagen de referencia	Qty Menge Qté. Qtà Cant.	Item no. Nr. N° d article Articolo No. Artículo No	Reference Image Referenzbild Image de référence Immagine di riferimento Imagen de referencia	Qty Menge Qté. Qtà Cant.
Ⓒ	 <p>DL</p> <p>L=250mm</p>	X2	Ⓙ	 <p>M6X12mm</p>	X8 +1
Ⓒ	 <p>DR</p> <p>L=250mm</p>	X2	Ⓚ	 <p>M6X50mm</p>	X4 +1
Ⓗ	 <p>Ø35mm</p>	X2	Ⓛ	 <p>148X30XØ35mm</p>	X2
Ⓛ	 <p>Ø4X25mm</p>	X12 +1	Ⓜ	 <p>260X30XØ35mm</p>	X2

# PARTS

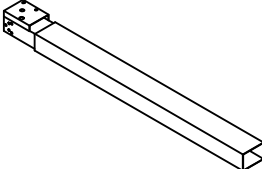
Item no. Nr. N °d article Articolo No. Artículo No	Reference Image Referenzbild Image de référence Immagine di riferimento Imagen de referencia	Qty Menge Qté. Qtà Cant.	Item no. Nr. N °d article Articolo No. Artículo No	Reference Image Referenzbild Image de référence Immagine di riferimento Imagen de referencia	Qty Menge Qté. Qtà Cant.
(N)	 M4X16mm	X8 +1	(R)	 M4X65mm	X1
(O)	 Ø21mm	X41 +3	(S)	 Ø35mm	X2
(P)	 250XØ5mm	X2	(AA)		X1
(Q)	 Ø3x14mm	X22 +2	(BB)		X1

# PARTS

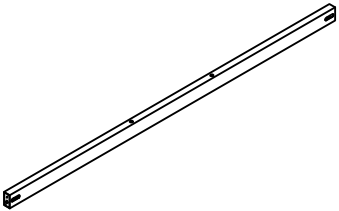
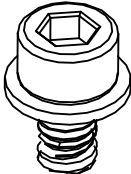
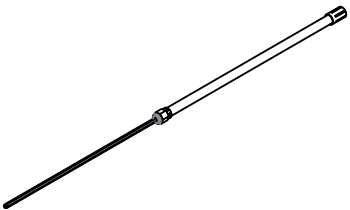
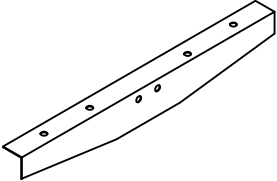
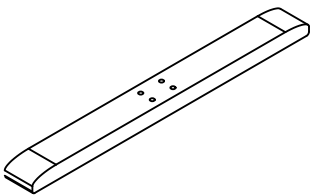
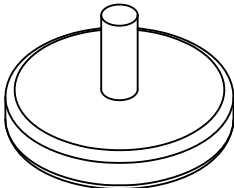
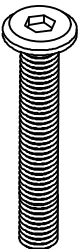
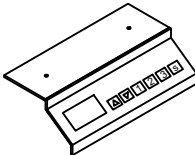
Item no. Nr. N °d article Articolo No. Artículo No	Reference Image Referenzbild Image de référence Immagine di riferimento Imagen de referencia	Qty Menge Qté. Qtà Cant.	Item no. Nr. N °d article Articolo No. Artículo No	Reference Image Referenzbild Image de référence Immagine di riferimento Imagen de referencia	Qty Menge Qté. Qtà Cant.
CC		X2	GG		X12 +1
DD		X1	HH		X2
EE		X1	II		X2
FF		X8 +1	JJ		X1

# PARTS

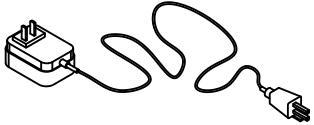
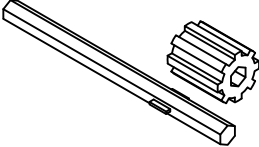
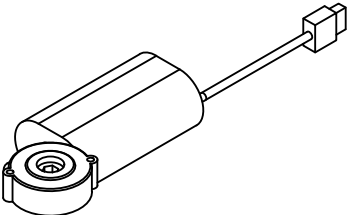
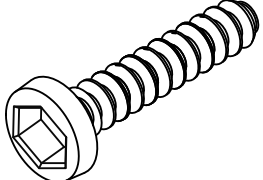
Item no. Nr N °d article Articolo No. Artículo No	Reference Image Referenzbild Image de référence Immagine di riferimento Imagen de referencia	Qty Menge Qté. Qtà Cant.
KK		X1
LL		X1
MM		X1
NN		X2 +1

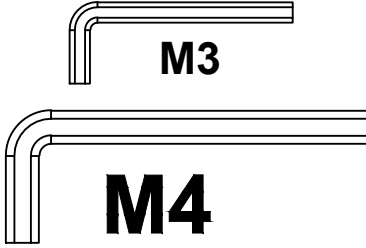
Item no. Nr N °d article Articolo No. Artículo No	Reference Image Referenzbild Image de référence Immagine di riferimento Imagen de referencia	Qty Menge Qté. Qtà Cant.
OO	 <p>M3</p> <p>M4</p>	X1

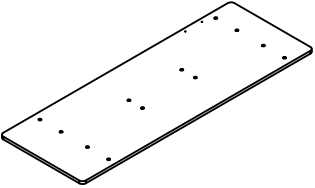
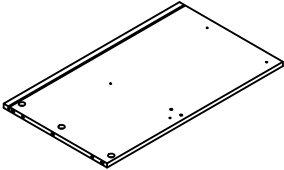
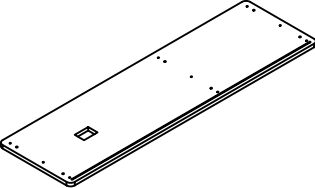
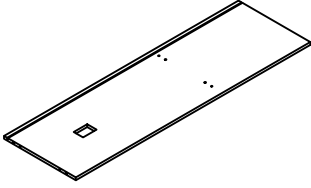
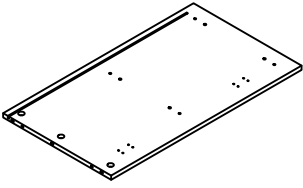
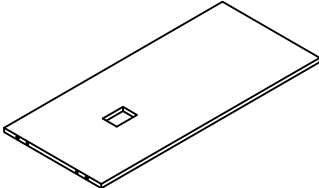
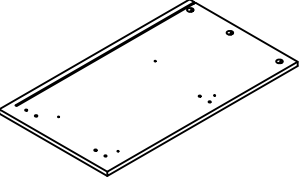
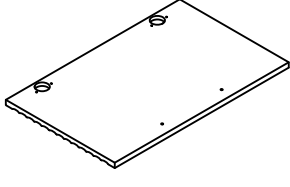
Item no. Nr N °d article Articolo No. Artículo No	Reference Image Referenzbild Image de référence Immagine di riferimento Imagen de referencia	Qty Menge Qté. Qtà Cant.	Item no. Nr N °d article Articolo No. Artículo No	Reference Image Referenzbild Image de référence Immagine di riferimento Imagen de referencia	Qty Menge Qté. Qtà Cant.
1		X1	5		X1
2		X1	6		X1
3		X1	7		X1
4		X1	8		X2

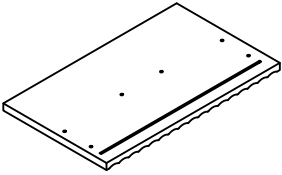
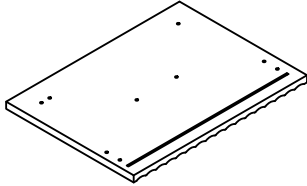
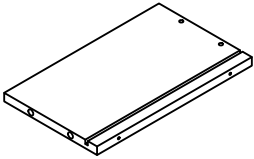
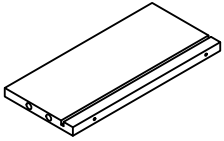
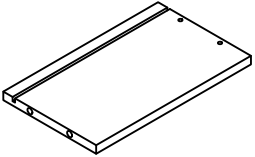
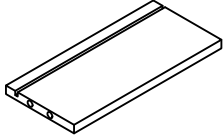
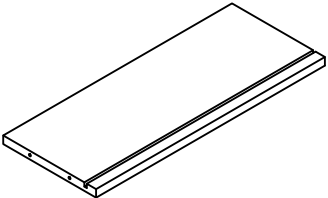
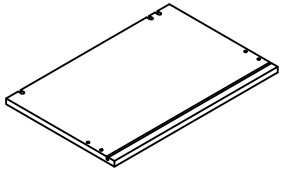
Item no. Nr N ° d article Articolo No. Artículo No	Reference Image Referenzbild Image de référence Immagine di riferimento Imagen de referencia	Qty Menge Qté. Qtà Cant.	Item no. Nr N ° d article Articolo No. Artículo No	Reference Image Referenzbild Image de référence Immagine di riferimento Imagen de referencia	Qty Menge Qté. Qtà Cant.
9		X1	13		X1
10		X1	14		X1
11		X1	15		X1
12		X1	16		X1

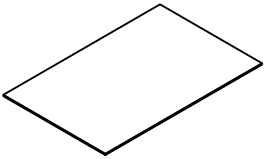
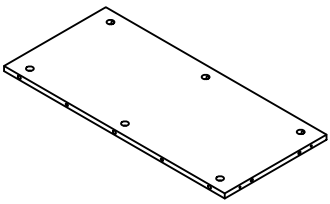
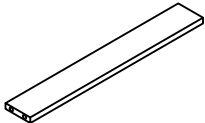
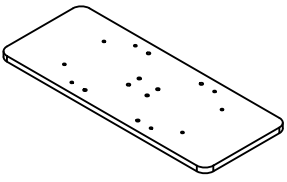
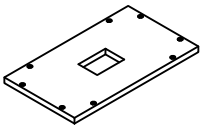
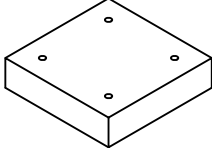
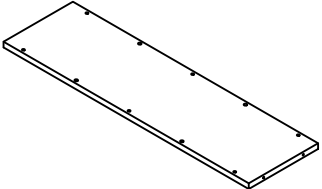
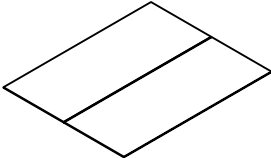
Item no. Nr N °d article Articolo No. Artículo No	Reference Image Referenzbild Image de référence Immagine di riferimento Imagen de referencia	Qty Menge Qté. Qtà Cant.	Item no. Nr N °d article Articolo No. Artículo No	Reference Image Referenzbild Image de référence Immagine di riferimento Imagen de referencia	Qty Menge Qté. Qtà Cant.
17		X2	21		X2
18		X1	22		X1
19		X1	23		X2
20		X2	24		X1

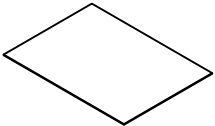
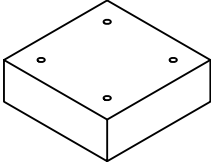
Item no. Nr . N °d article Articolo No. Artículo No	Reference Image Referenzbild Image de référence Immagine di riferimento Imagen de referencia	Qty Menge Qté. Qtà Cant.
25		X1
26		X1

# EXPLODED VIEW

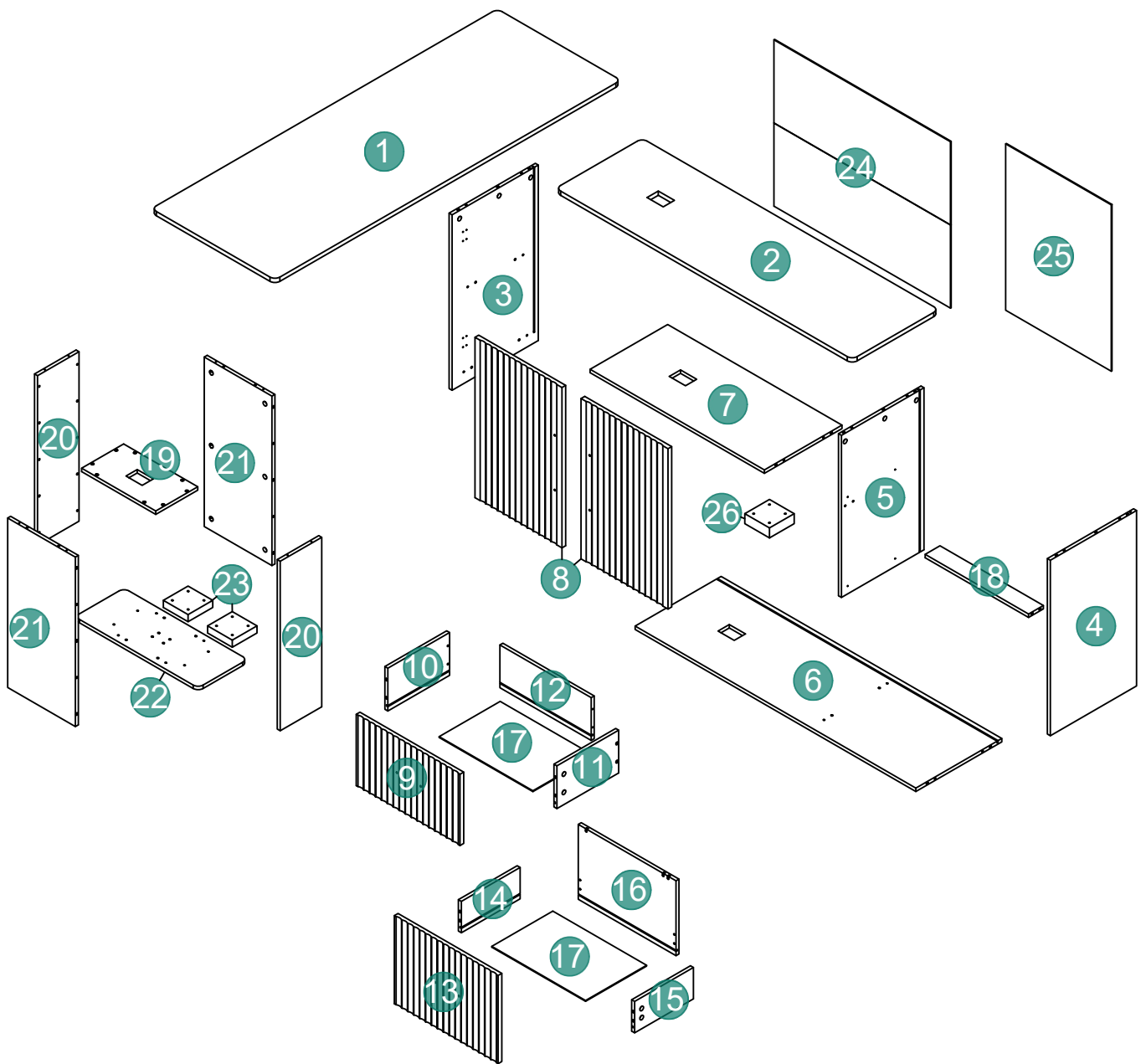



2

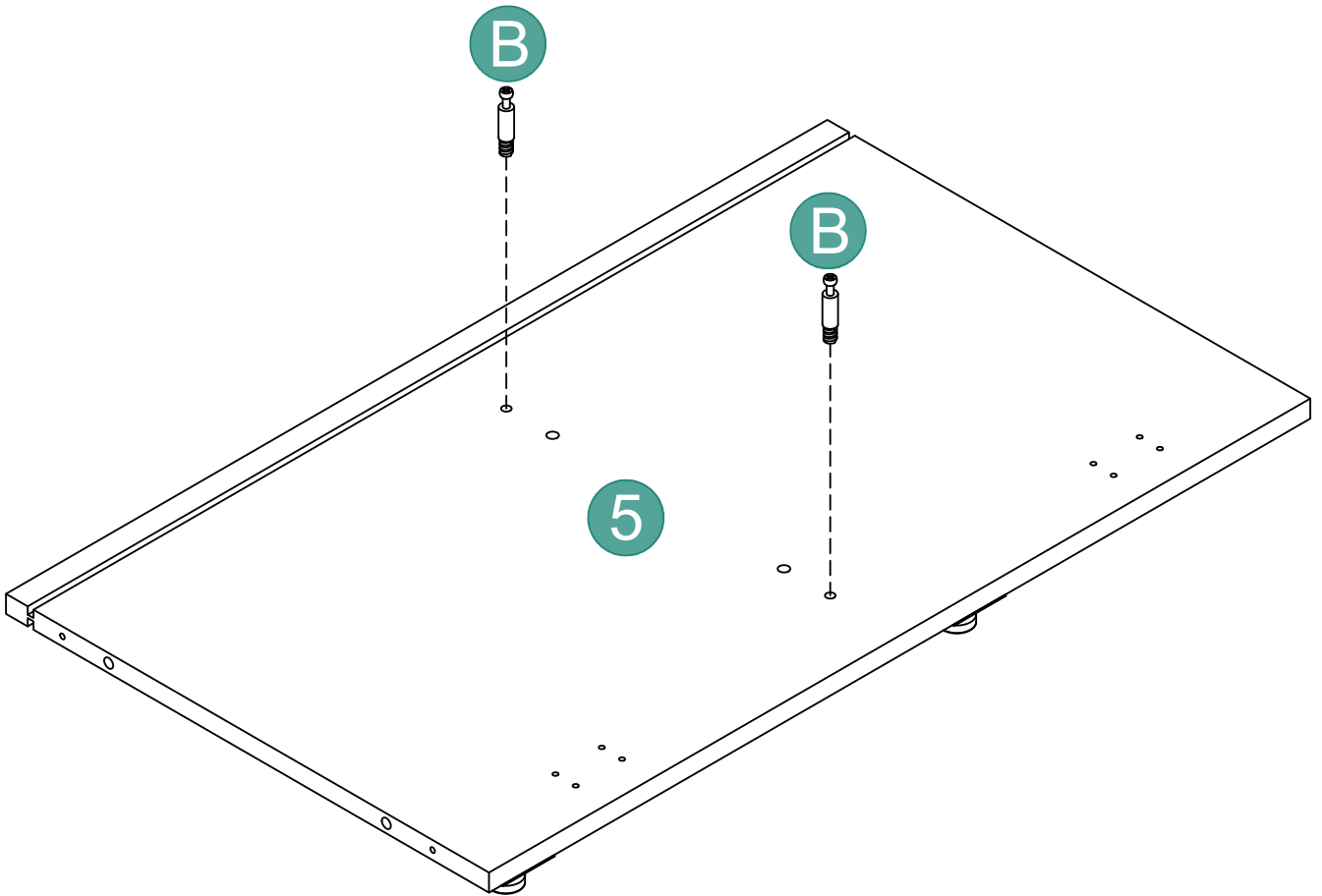
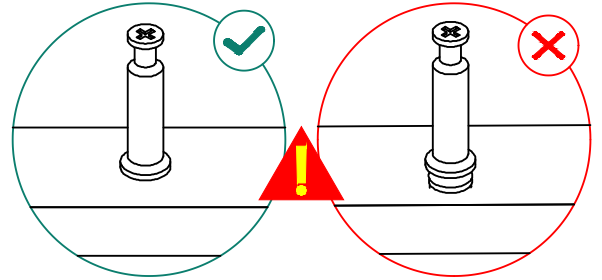
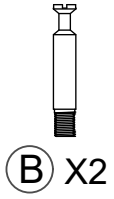

3

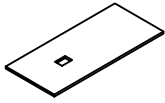

⑦ X1



Ⓐ X2



Ⓒ X2

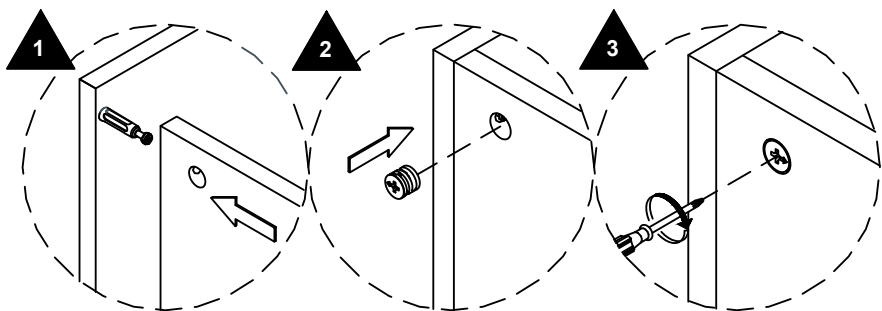
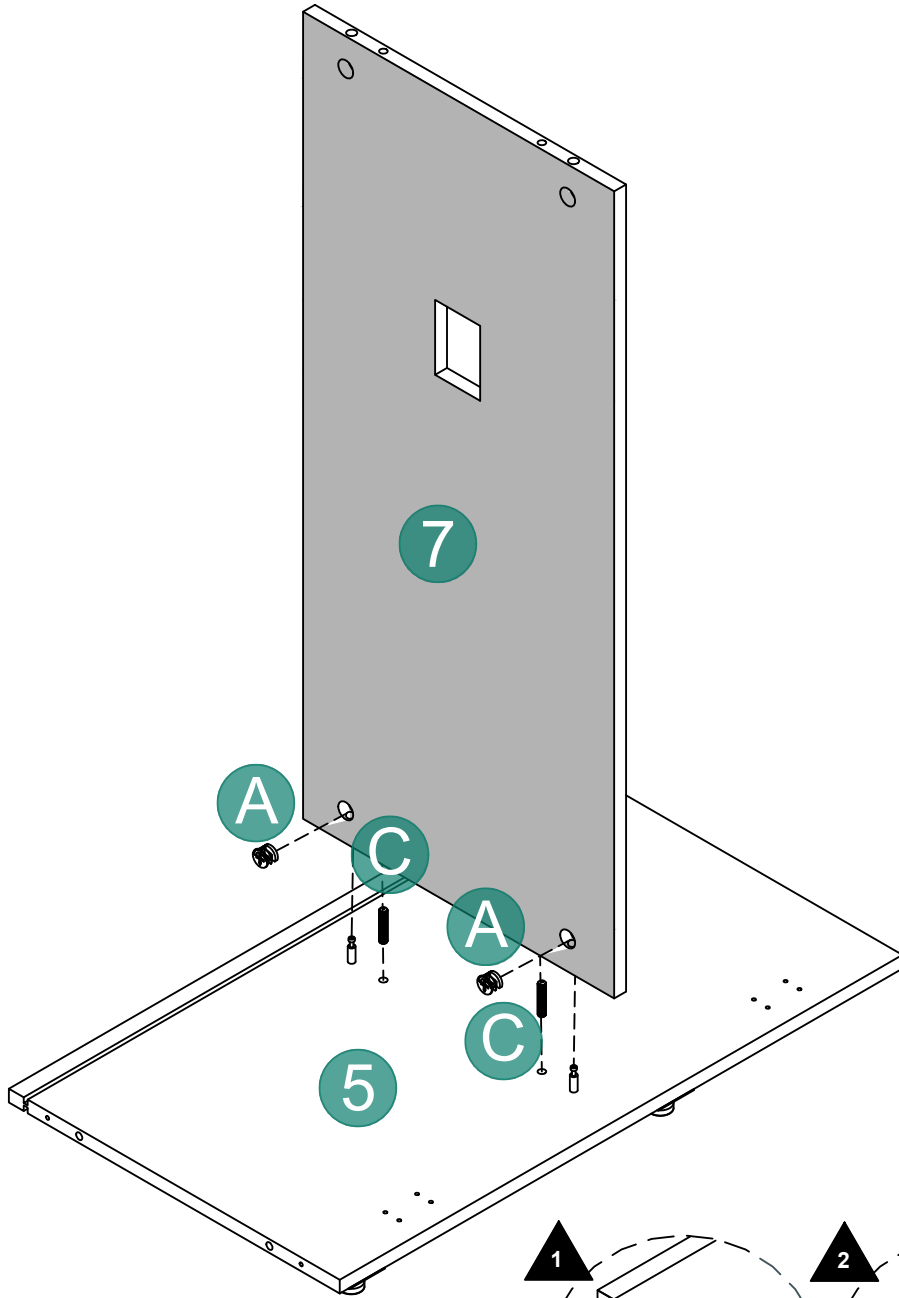

4

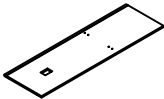

⑥ X1



③ X2



④ X2



⑤ X2

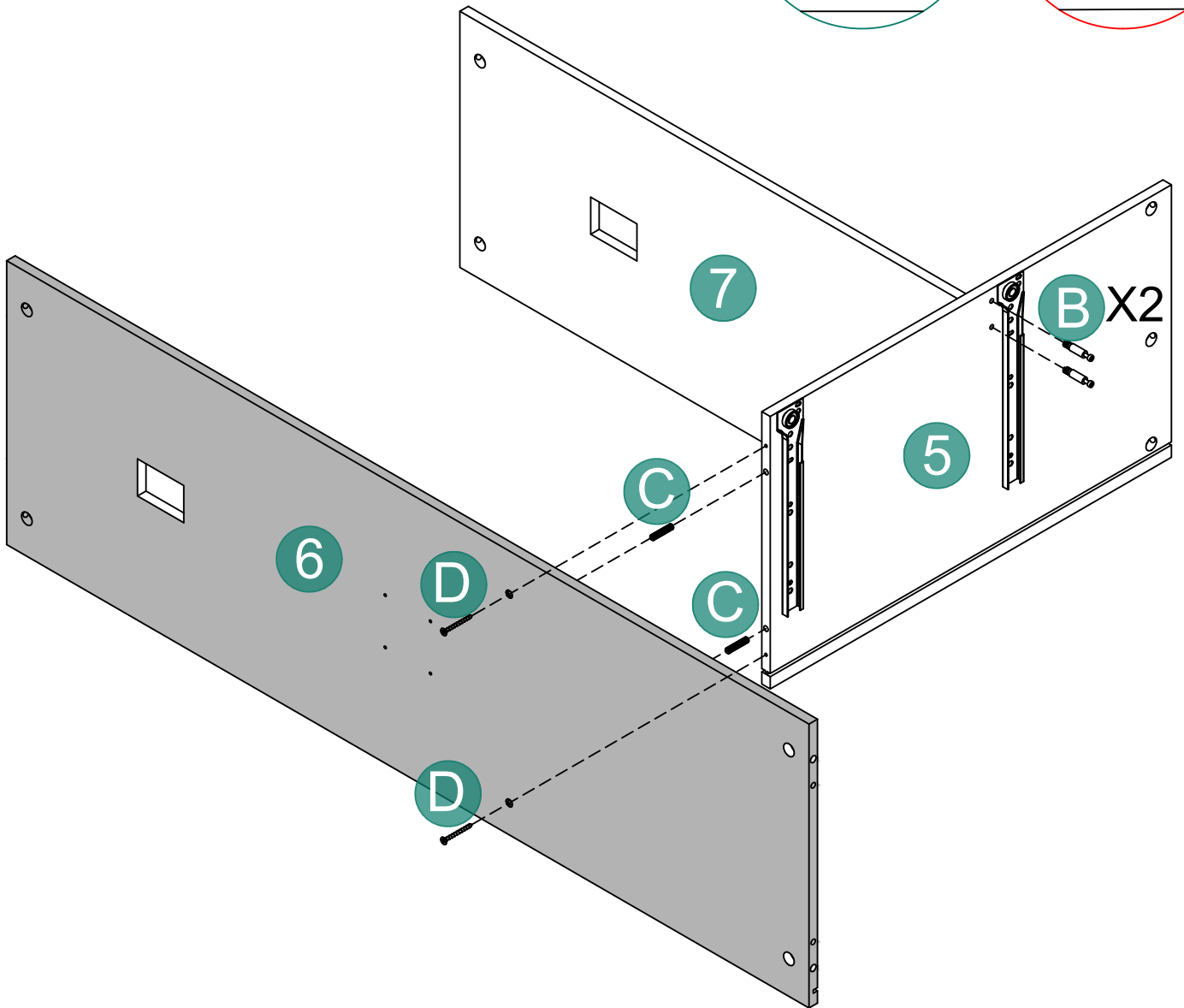
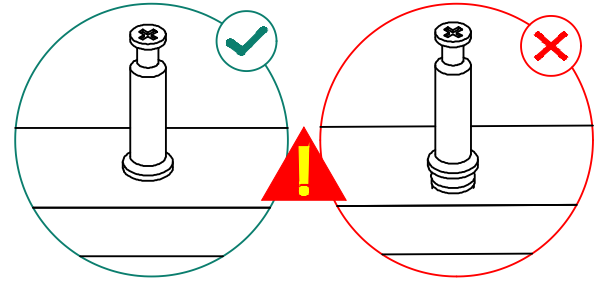

5

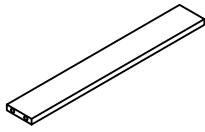

18 X1

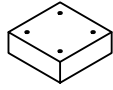

26 X1



A X2



I X4

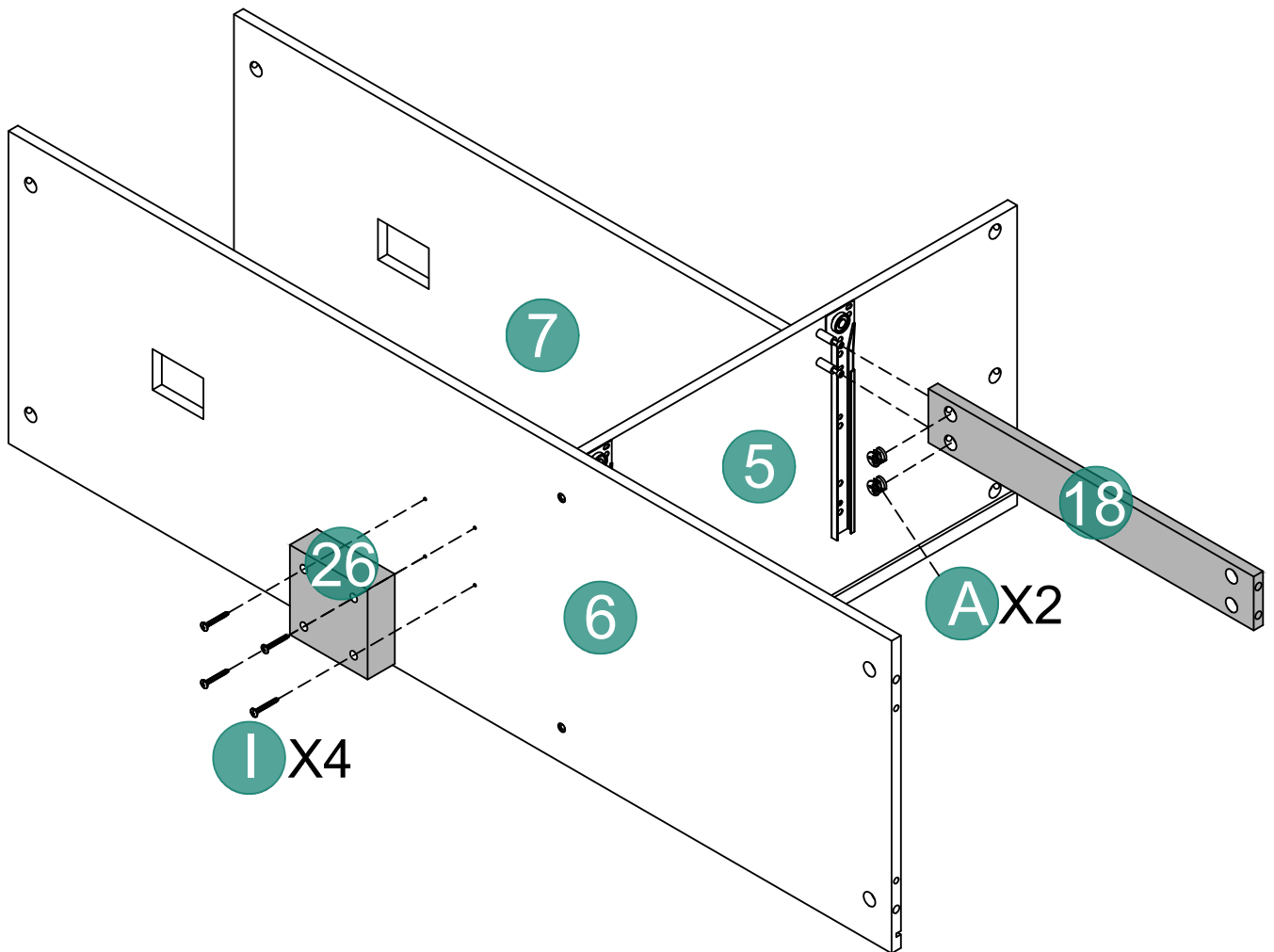

6

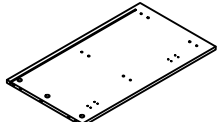

③ X1



Ⓑ X4

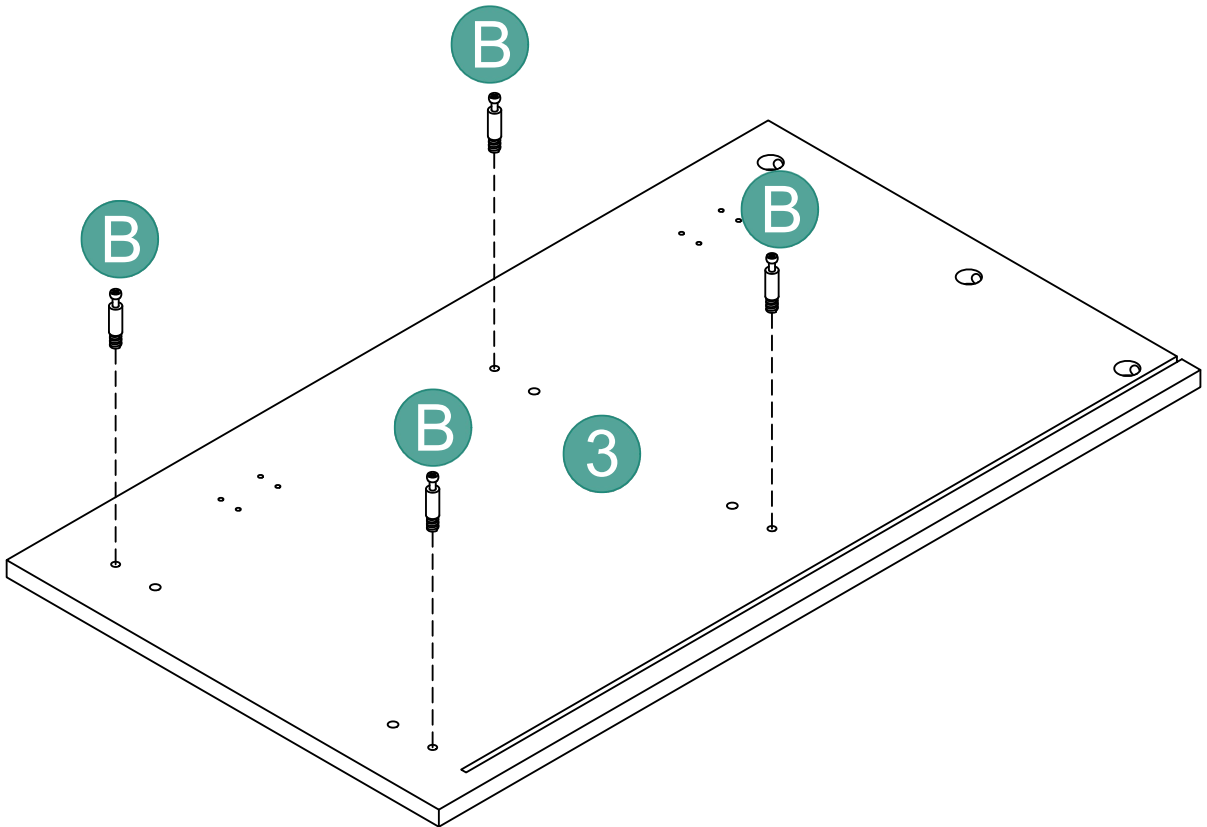
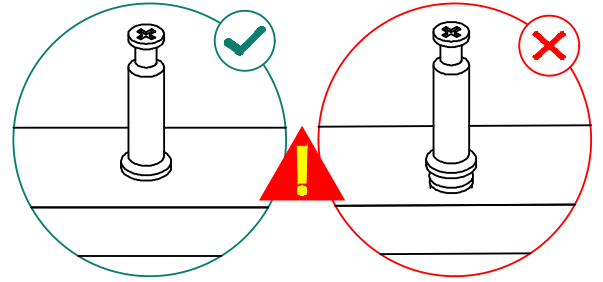

7

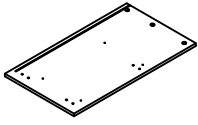

④ X1



Ⓑ X4

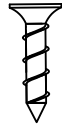

Ⓔ X4

CR



Ⓖ X2

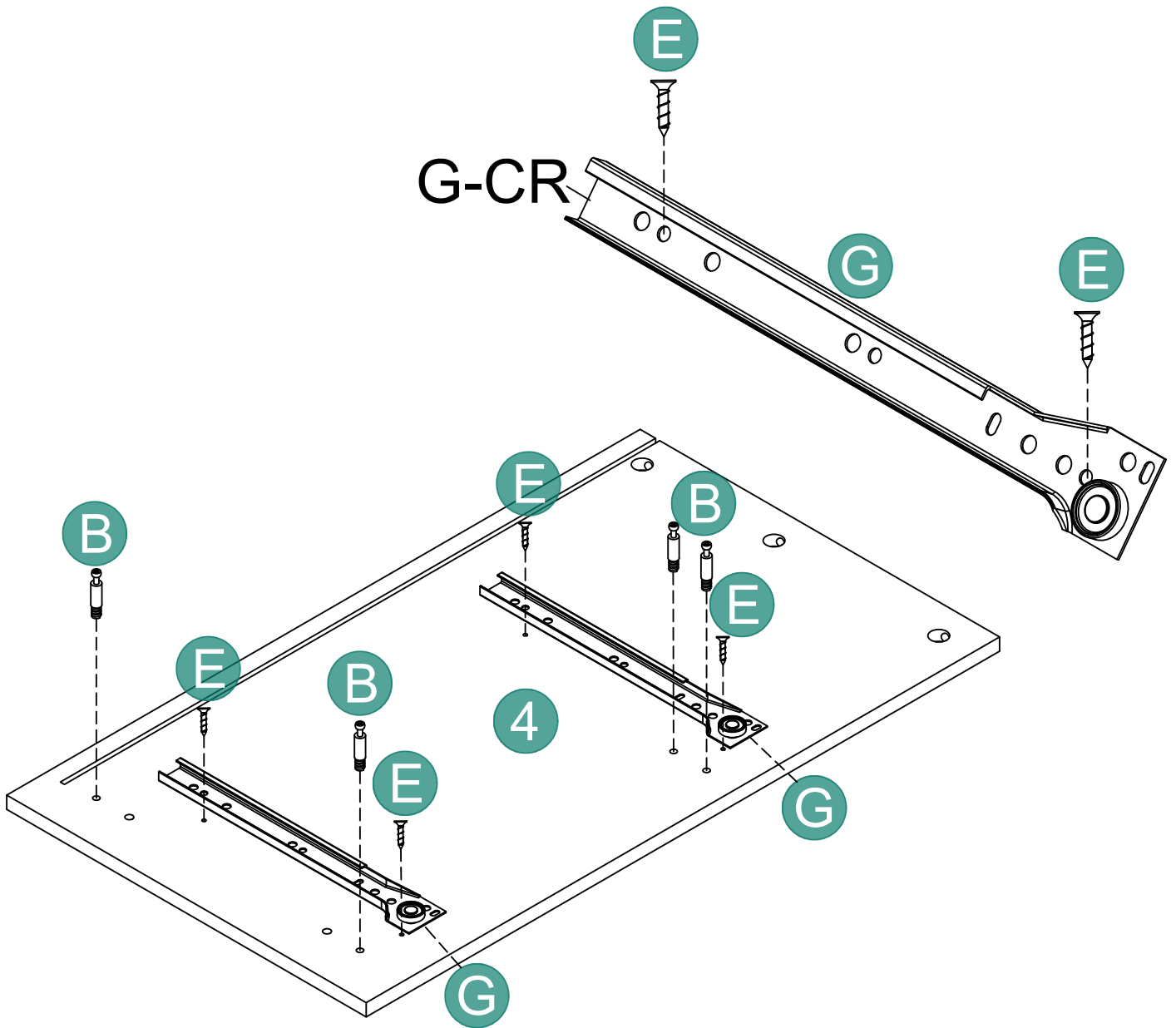

8

  
A X8

  
C X6

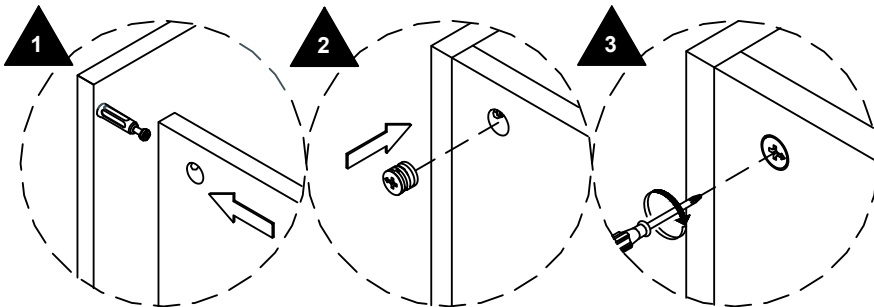
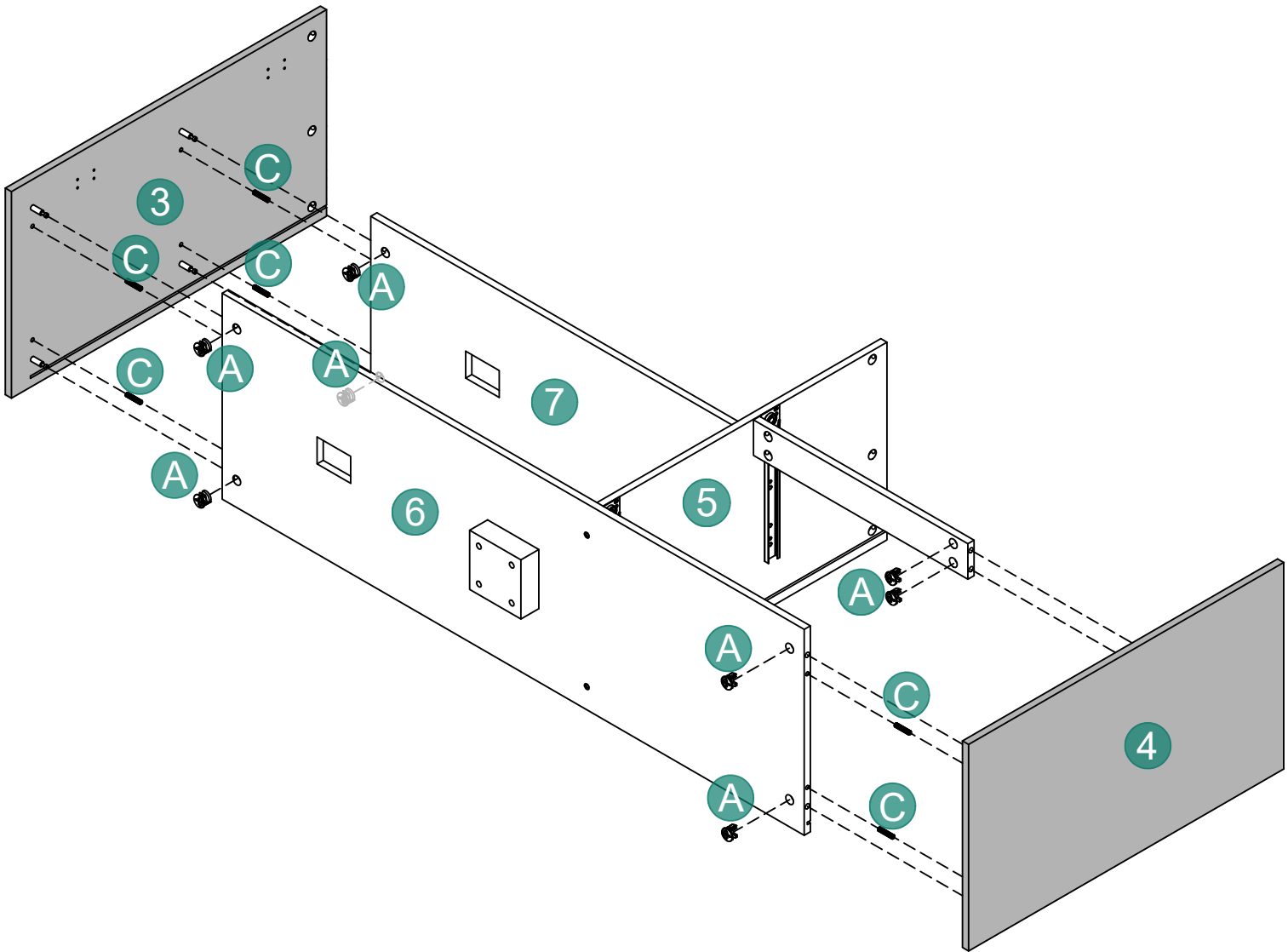

9

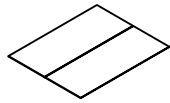

24 X1

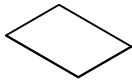

25 X1

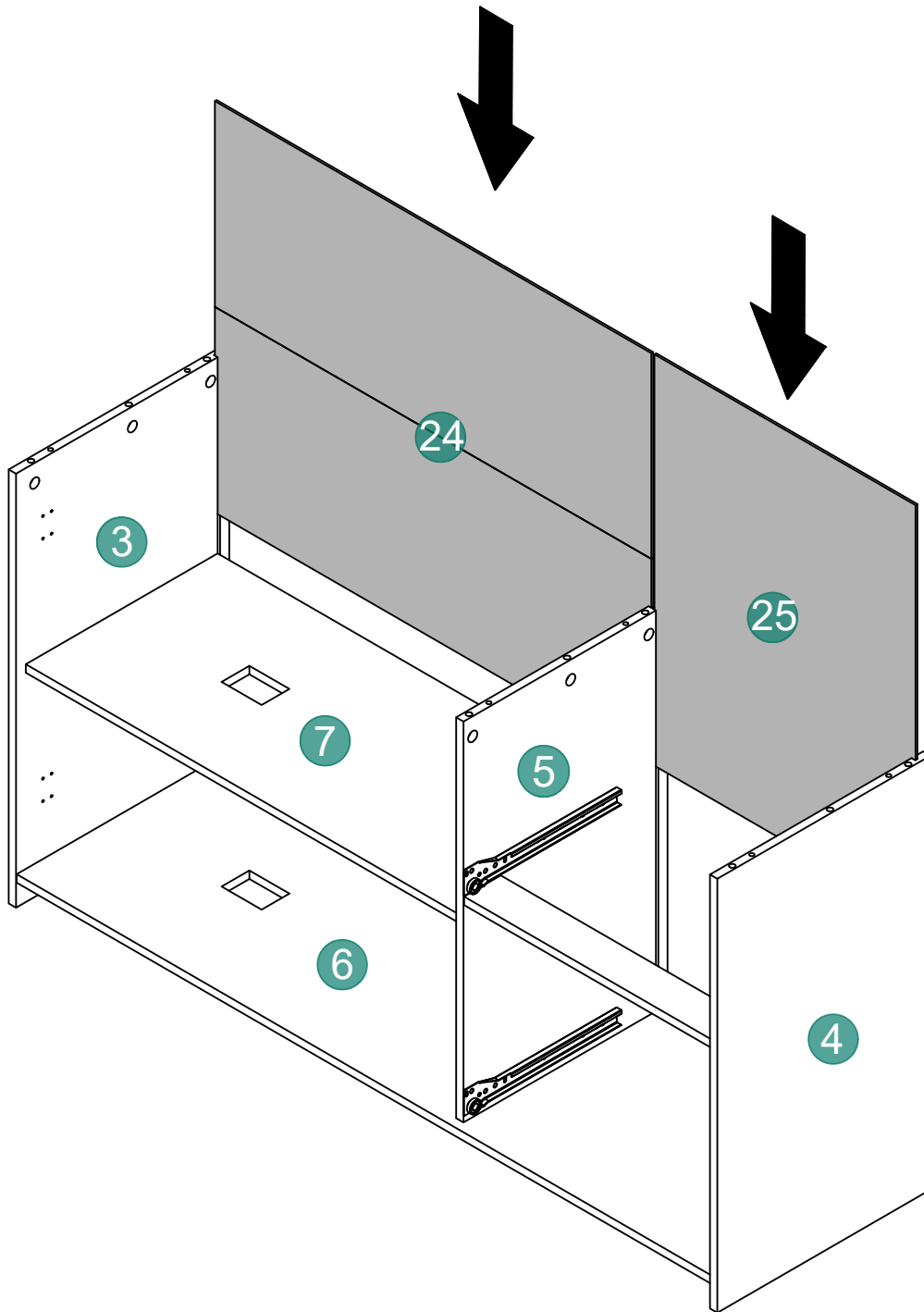

# 10

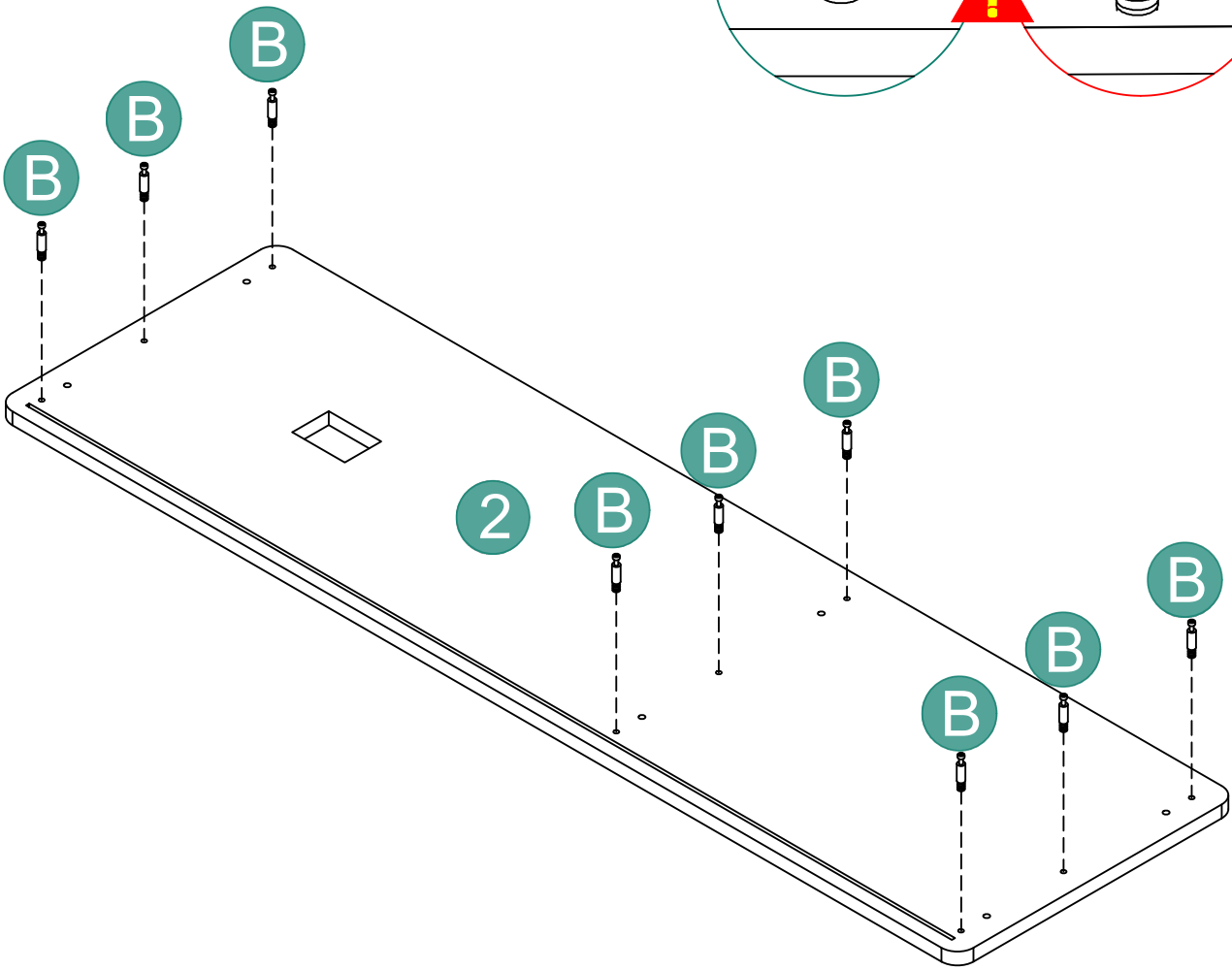
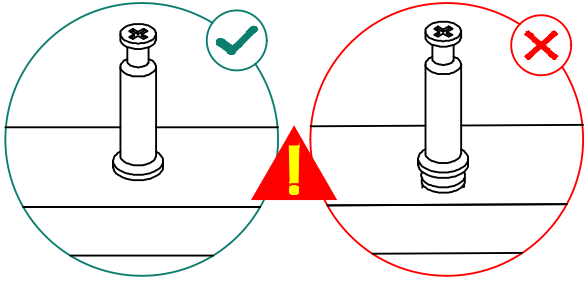
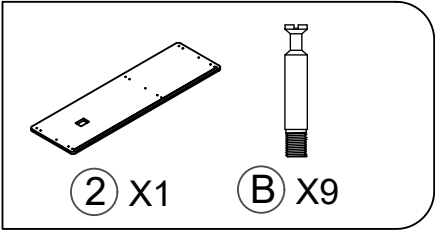

# 11

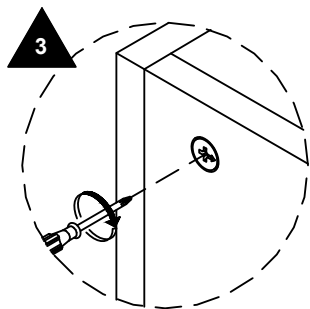
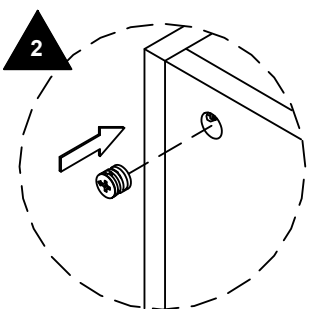
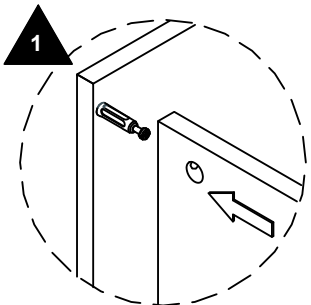
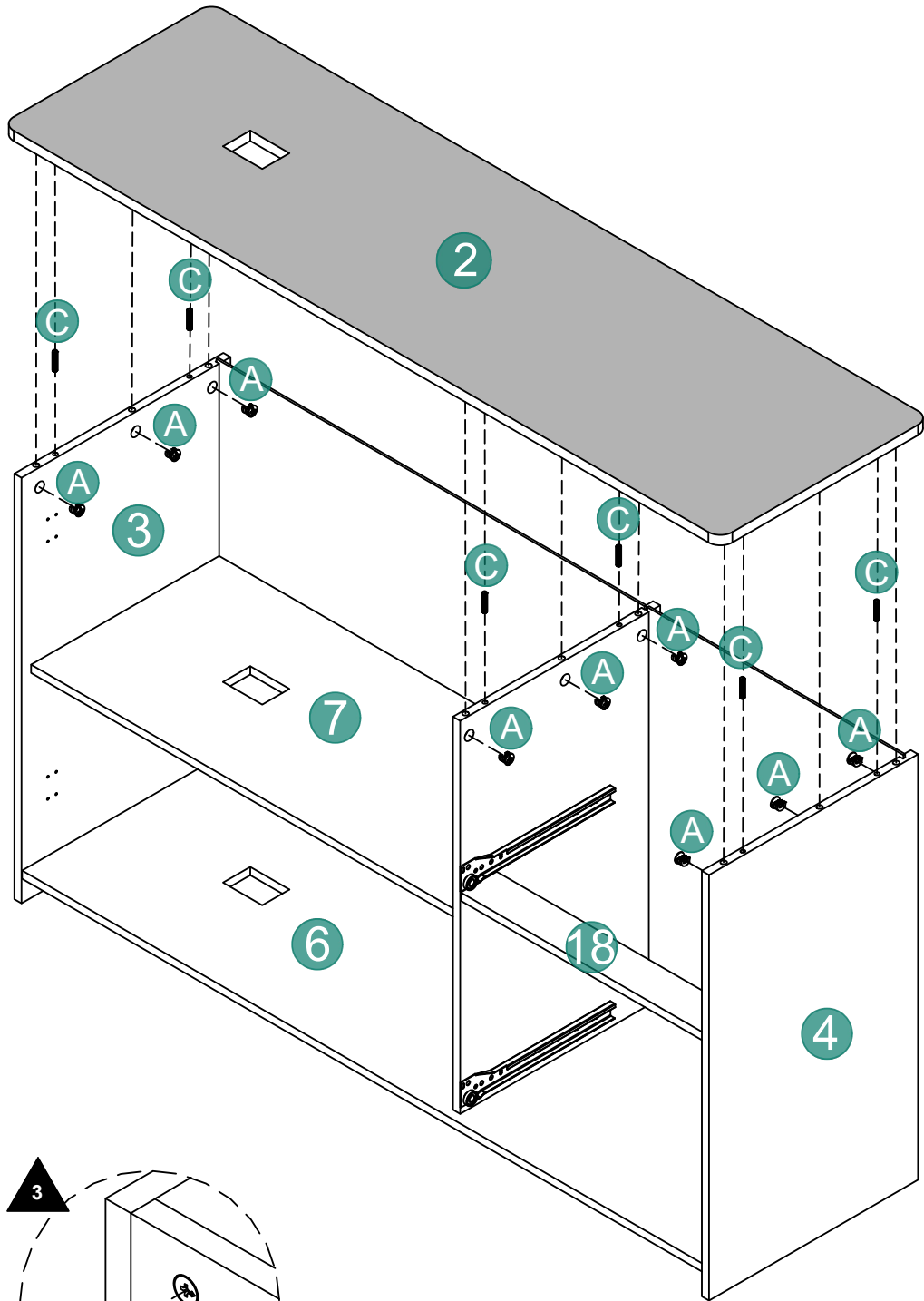
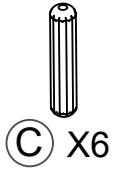

12

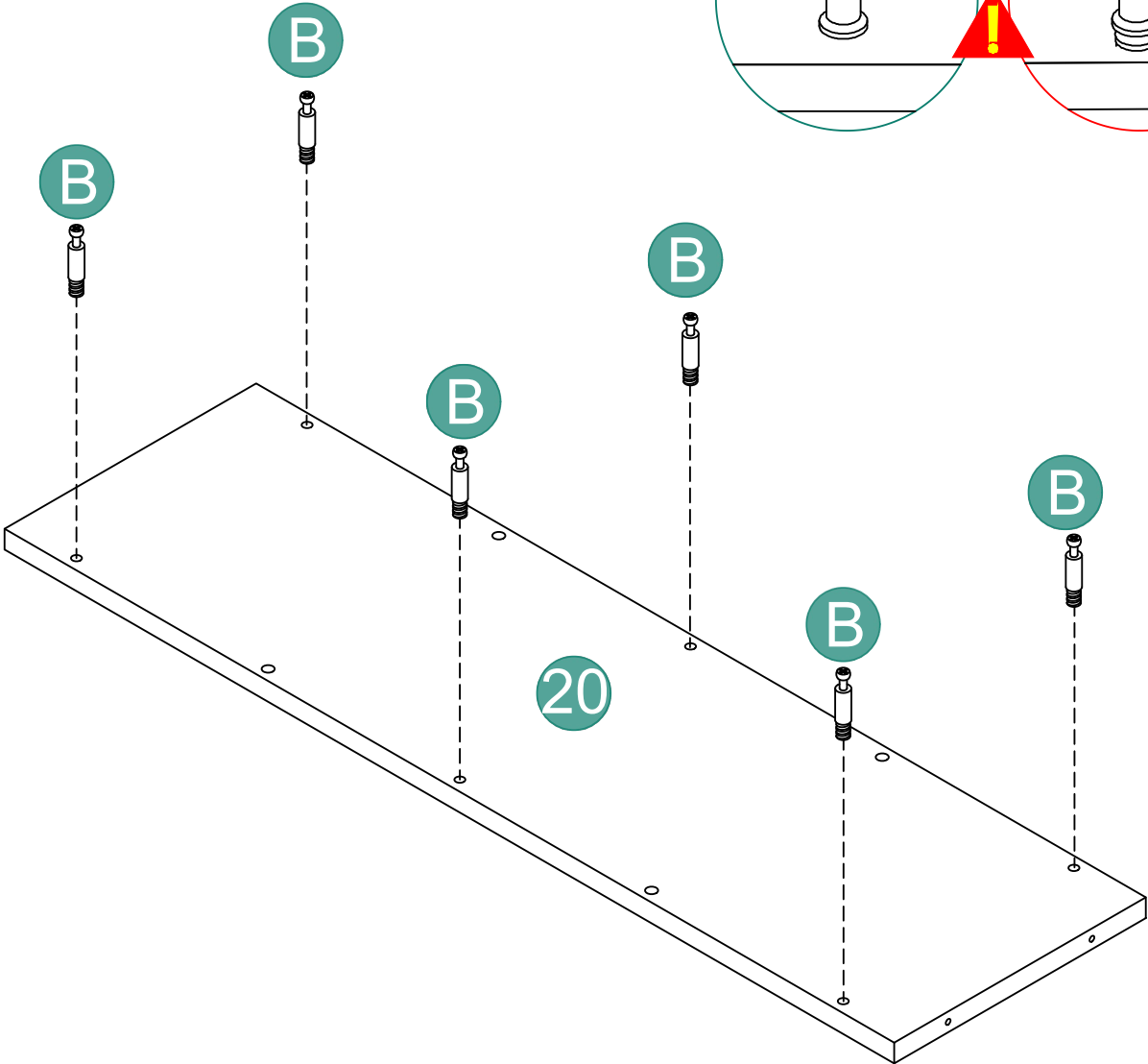
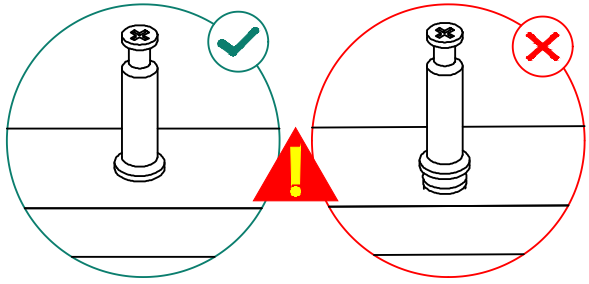
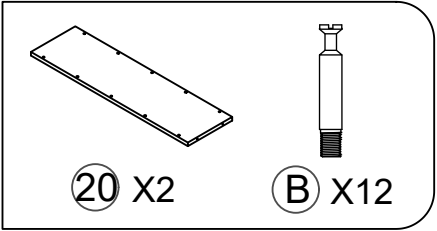

X2

# 13

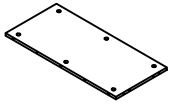

21 X2



A X6



C X4

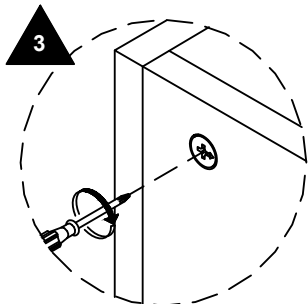
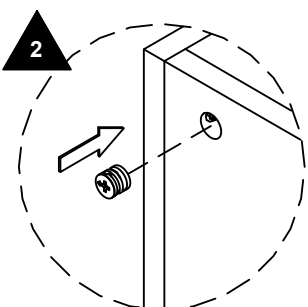
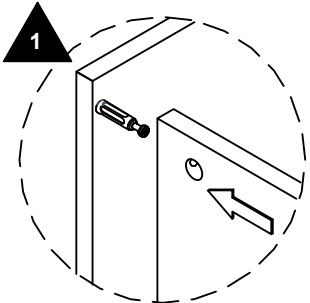
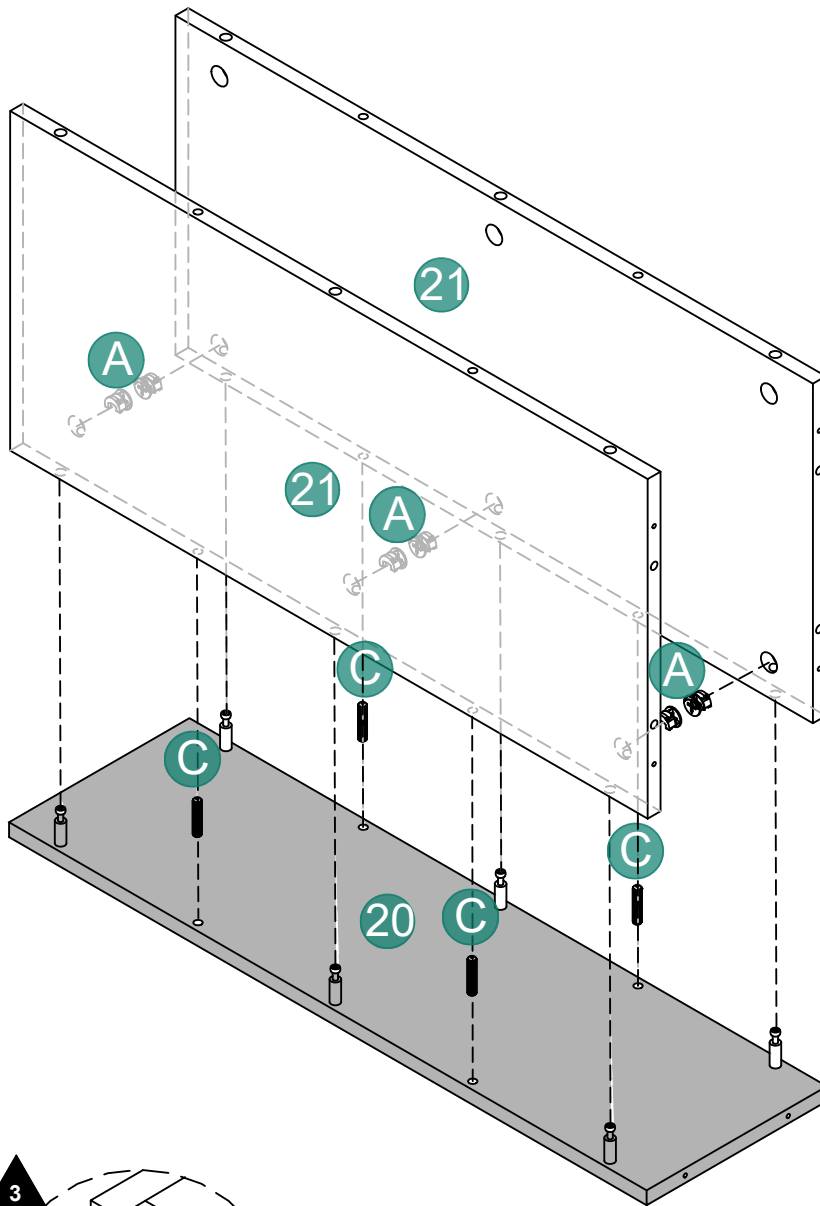

14

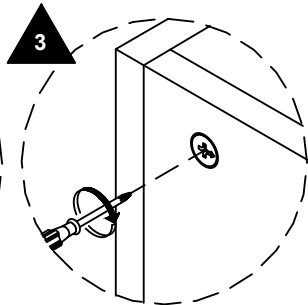
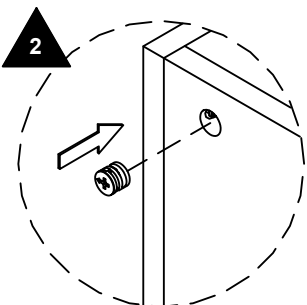
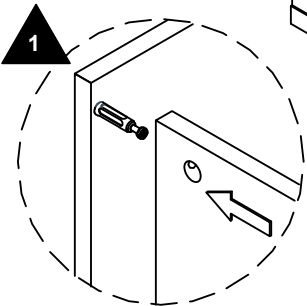
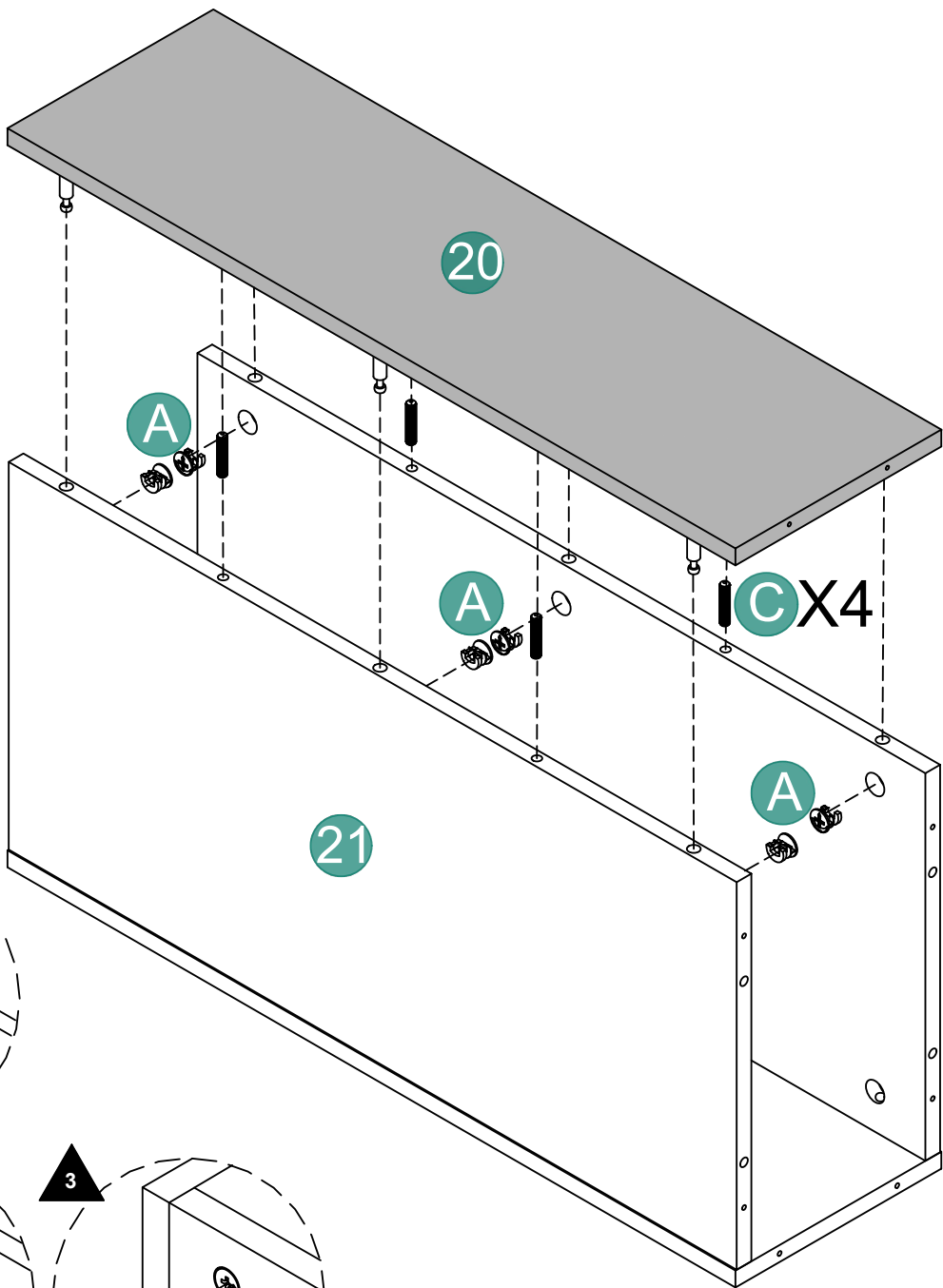
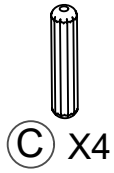

15

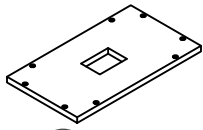

19 X1



C X4



D X8

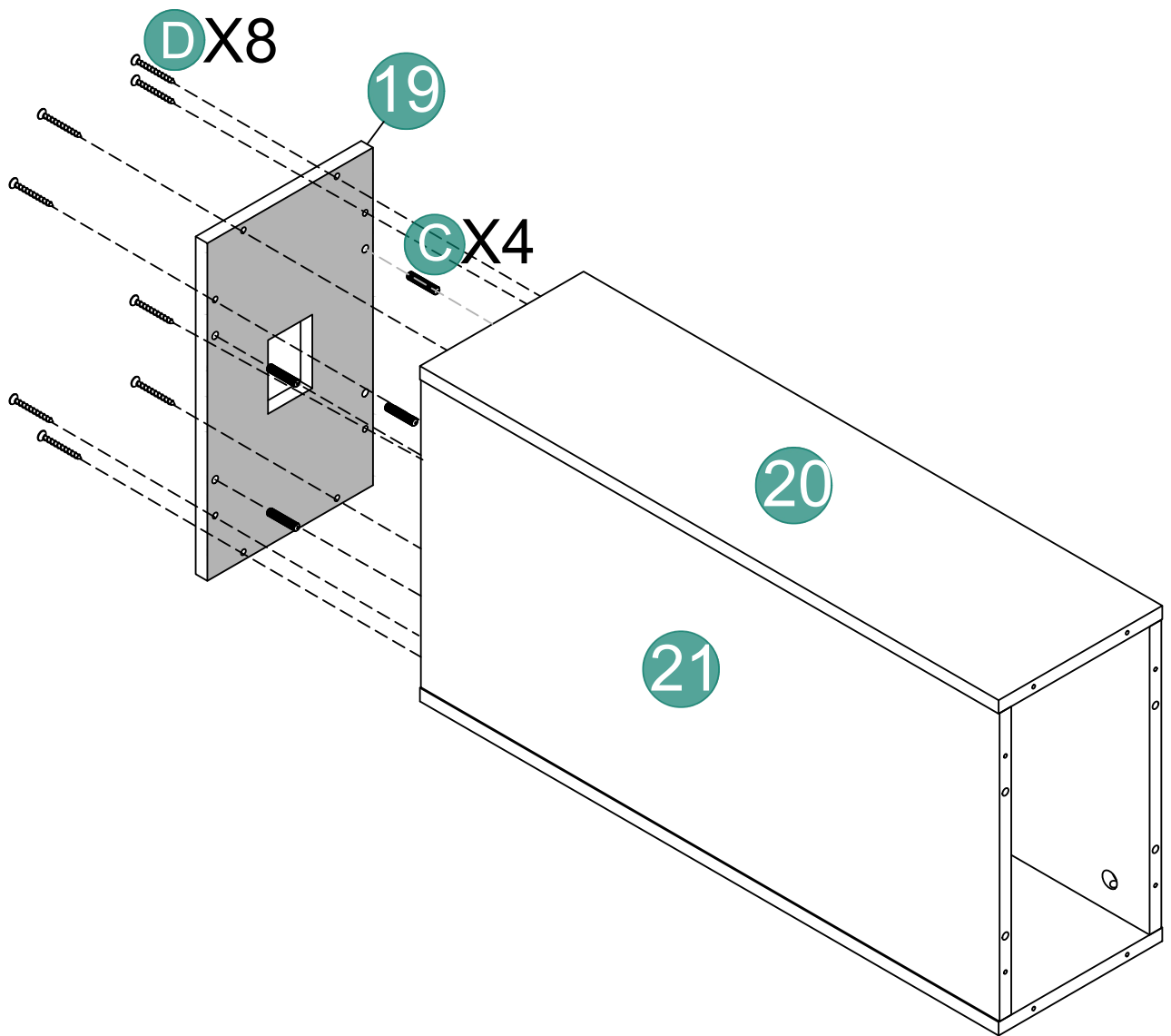

**16**

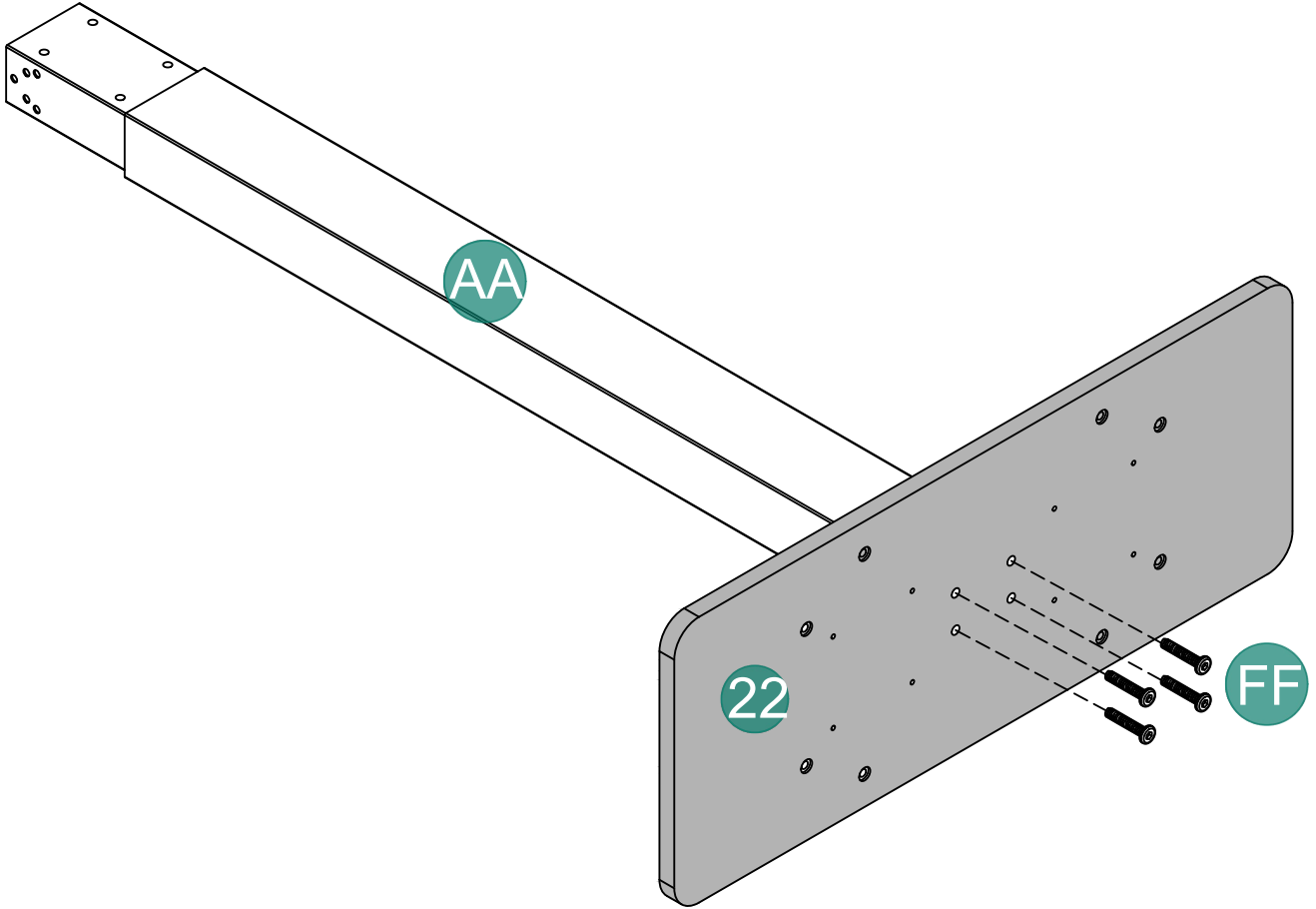
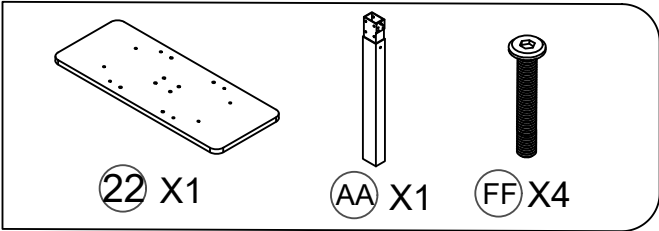

17

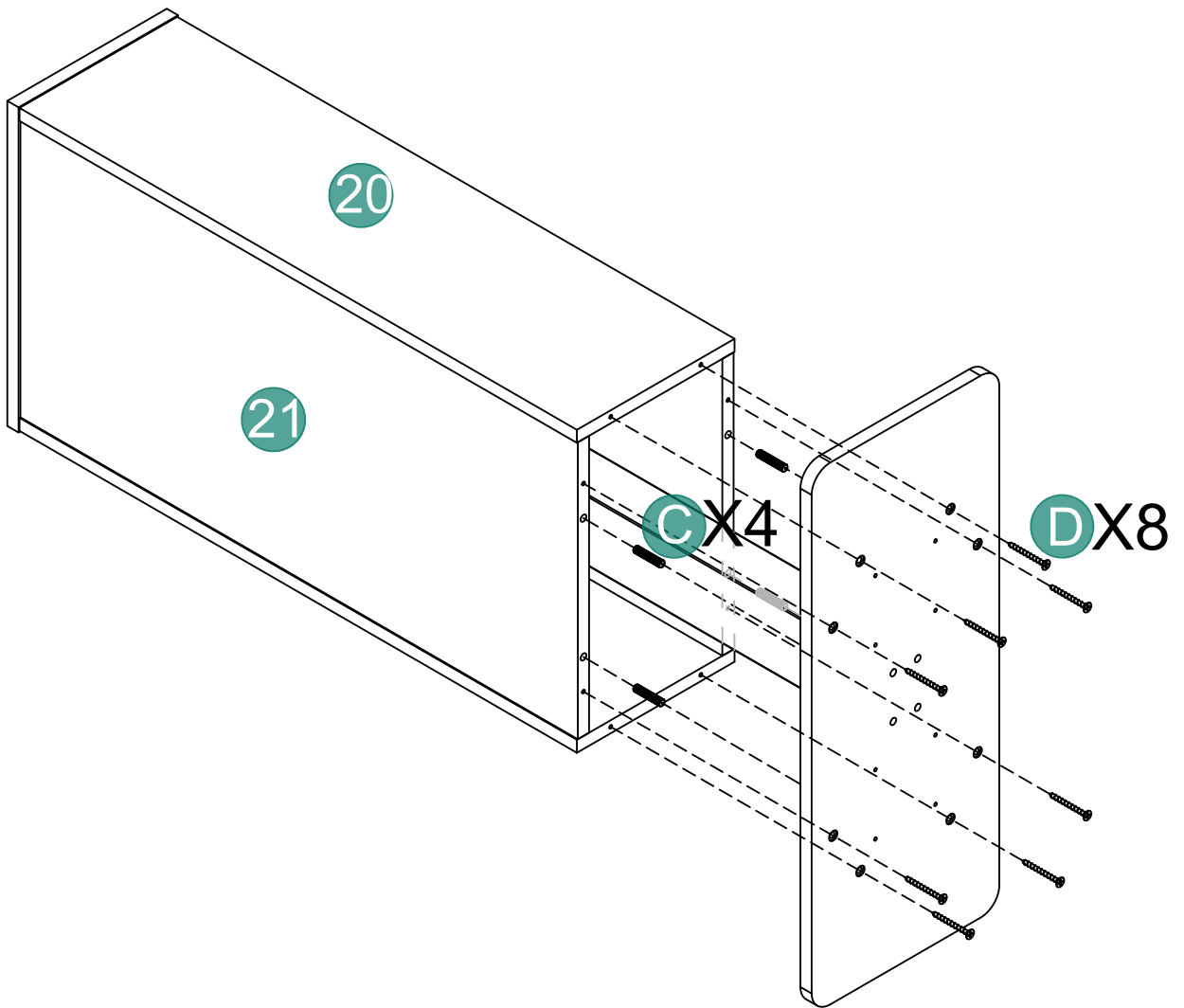
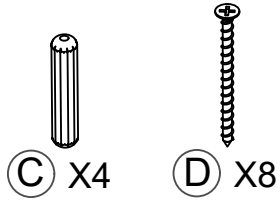

18

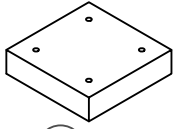

23 X2



1 X8

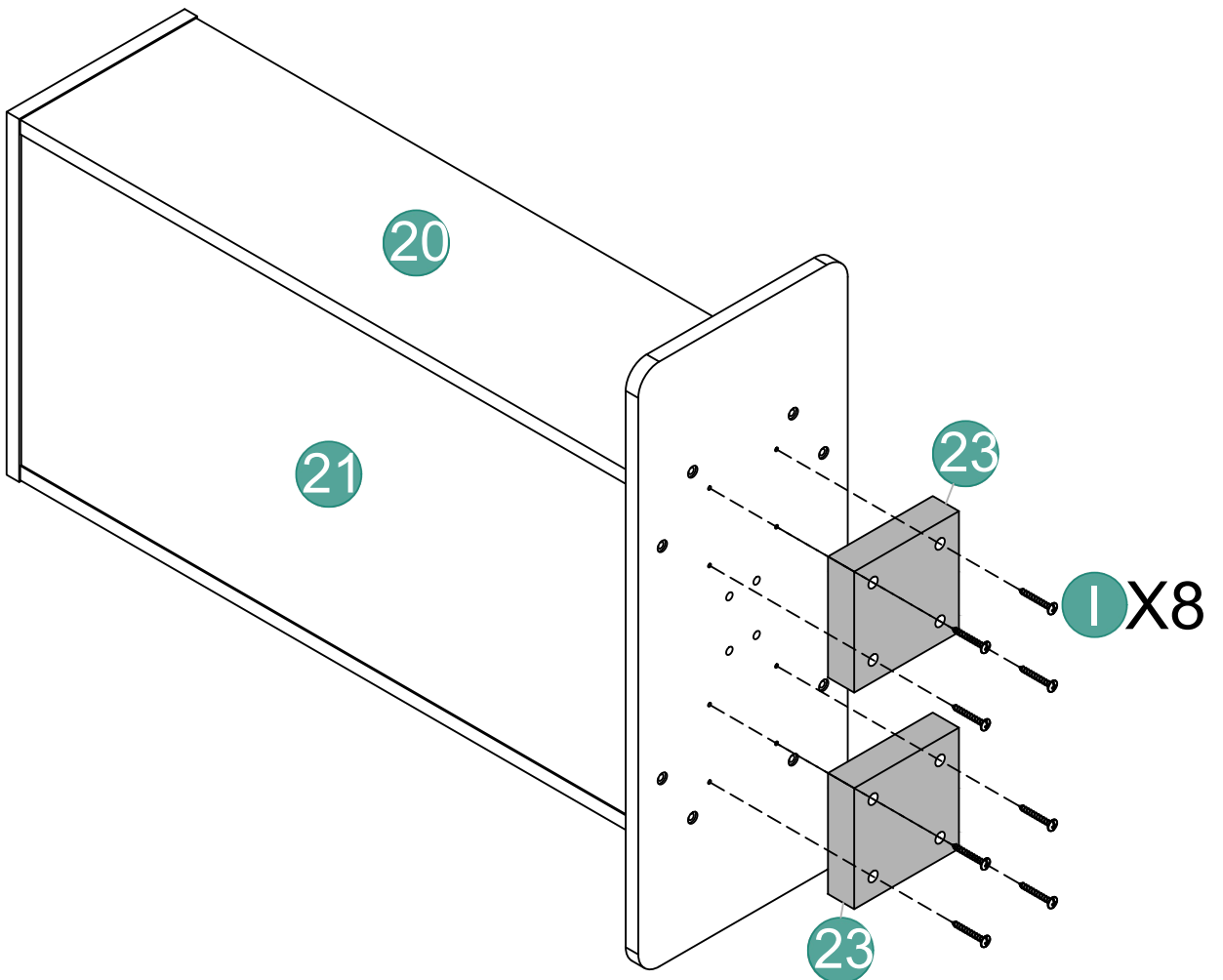

# 19

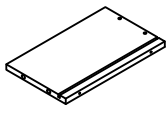

⑩ X1

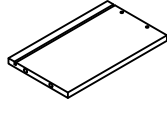

⑪ X1

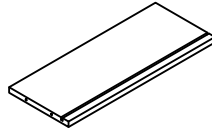

⑫ X1

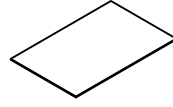

⑰ X1



ⓓ X4

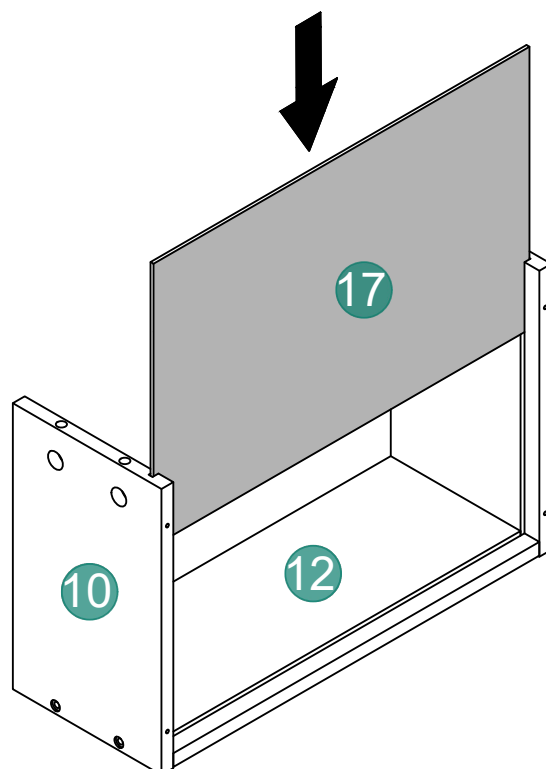
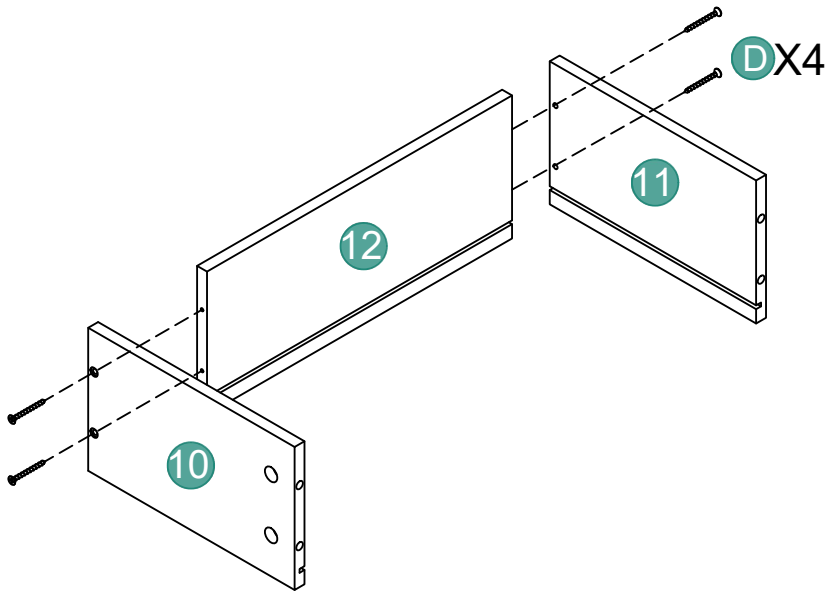

20

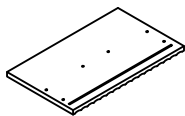

9 X1



A X4



B X4

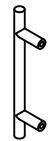

L X1



N X2

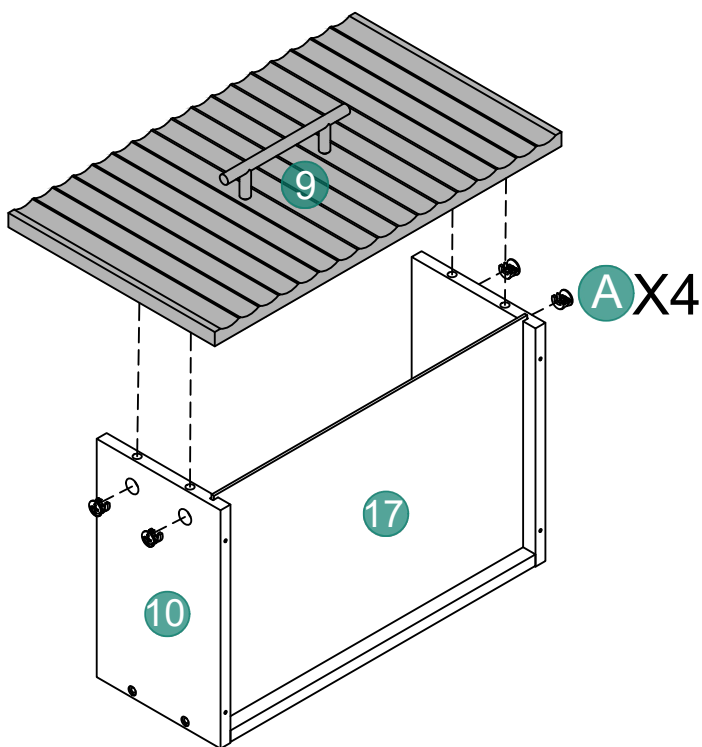
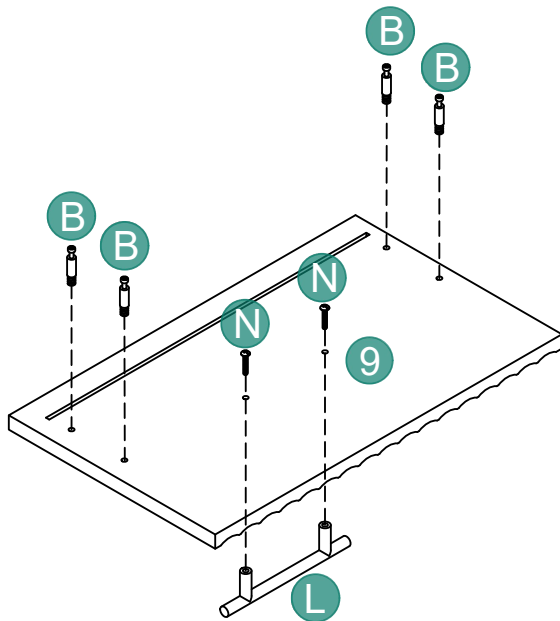

21

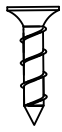

(E) X4

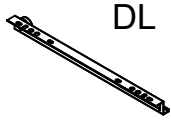

(G) X1

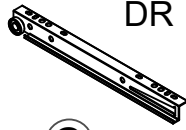

(G) X1

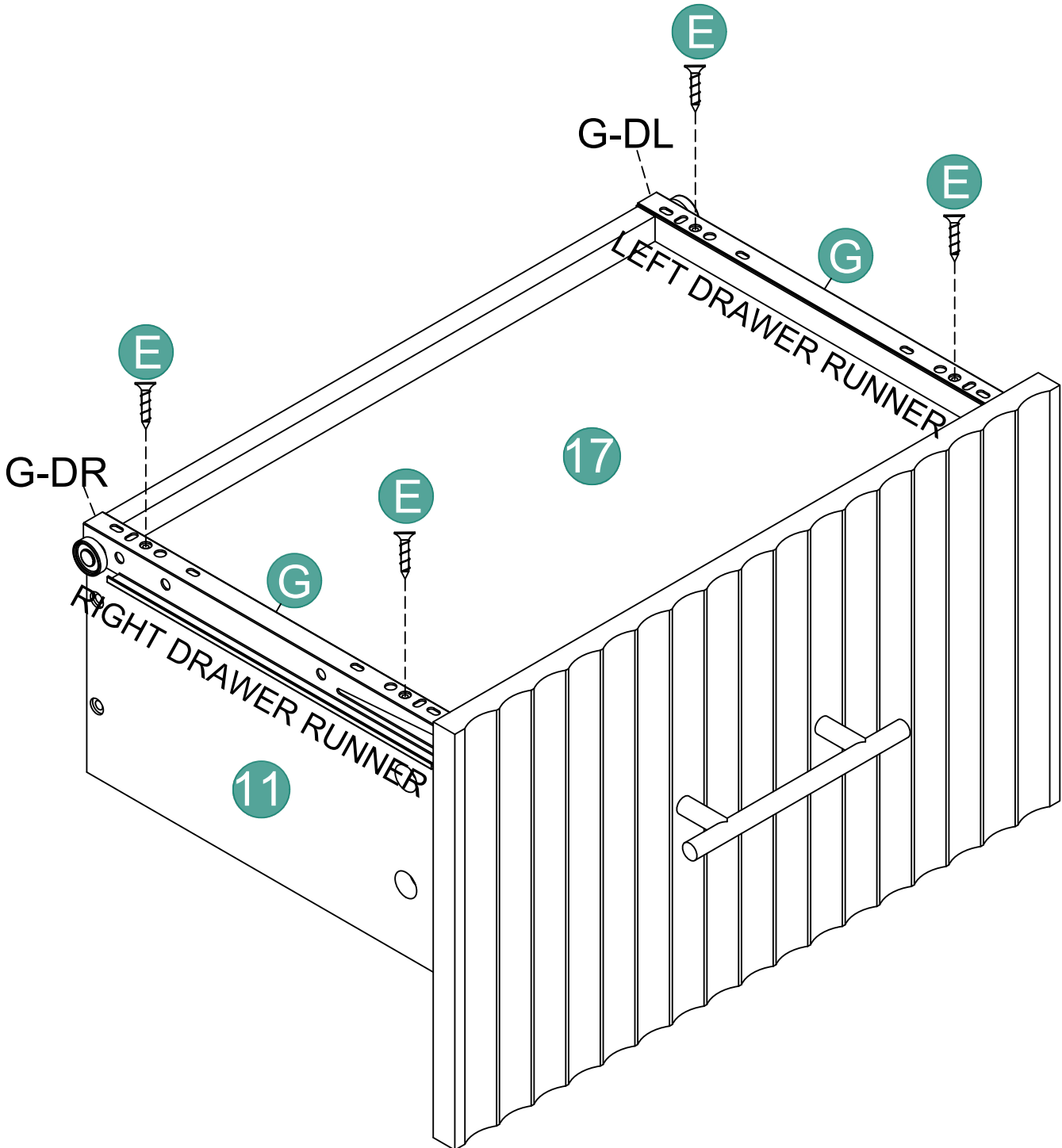

# 22

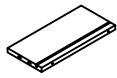

14 X1

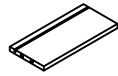

15 X1

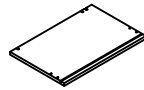

16 X1

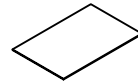

17 X1



D X4

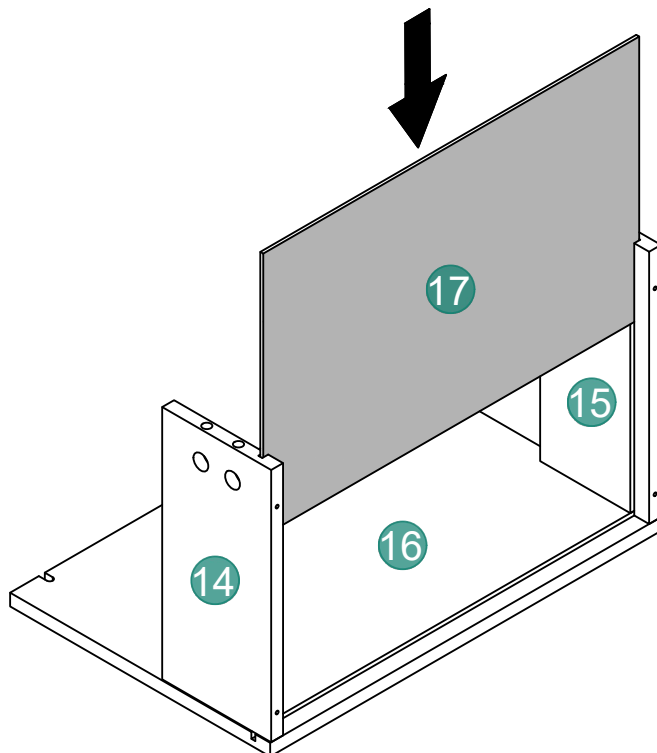
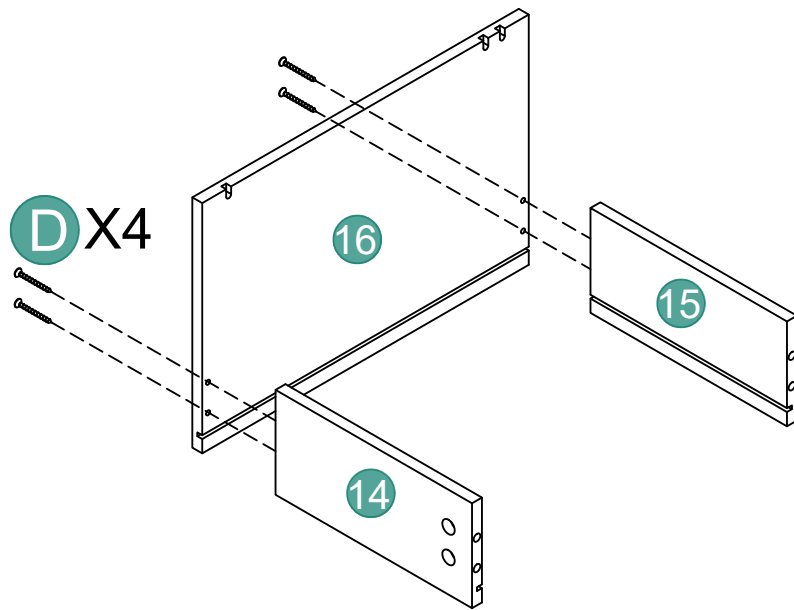

# 23

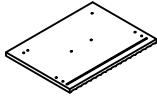

13 X1



A X4



B X4

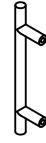

L X1



N X2

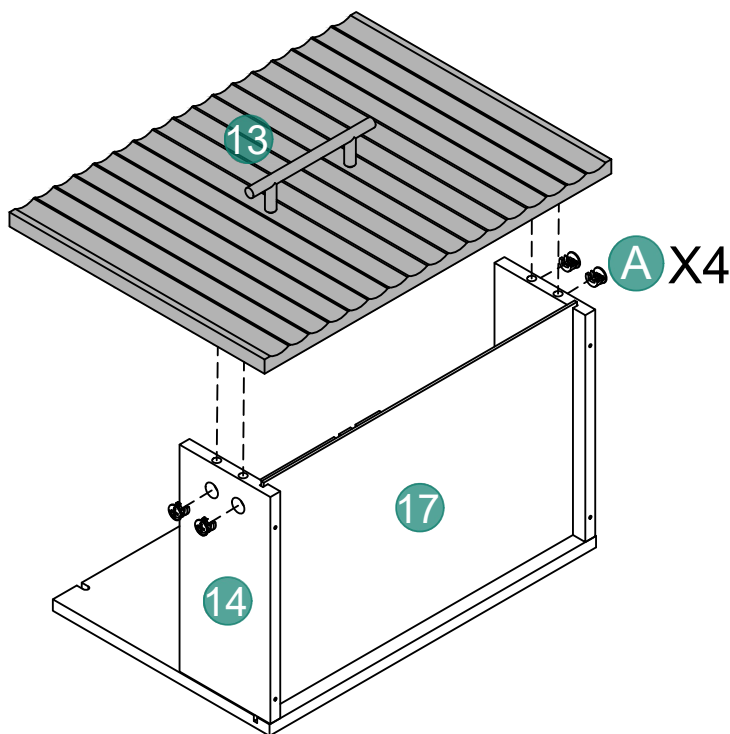
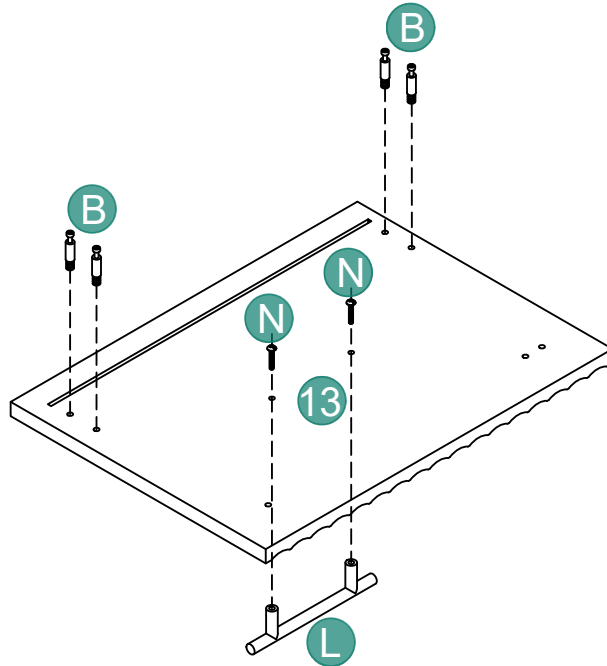

24

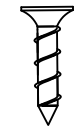

(E) X4

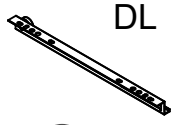

DL

(G) X1

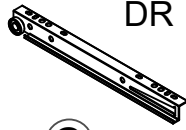

DR

(G) X1

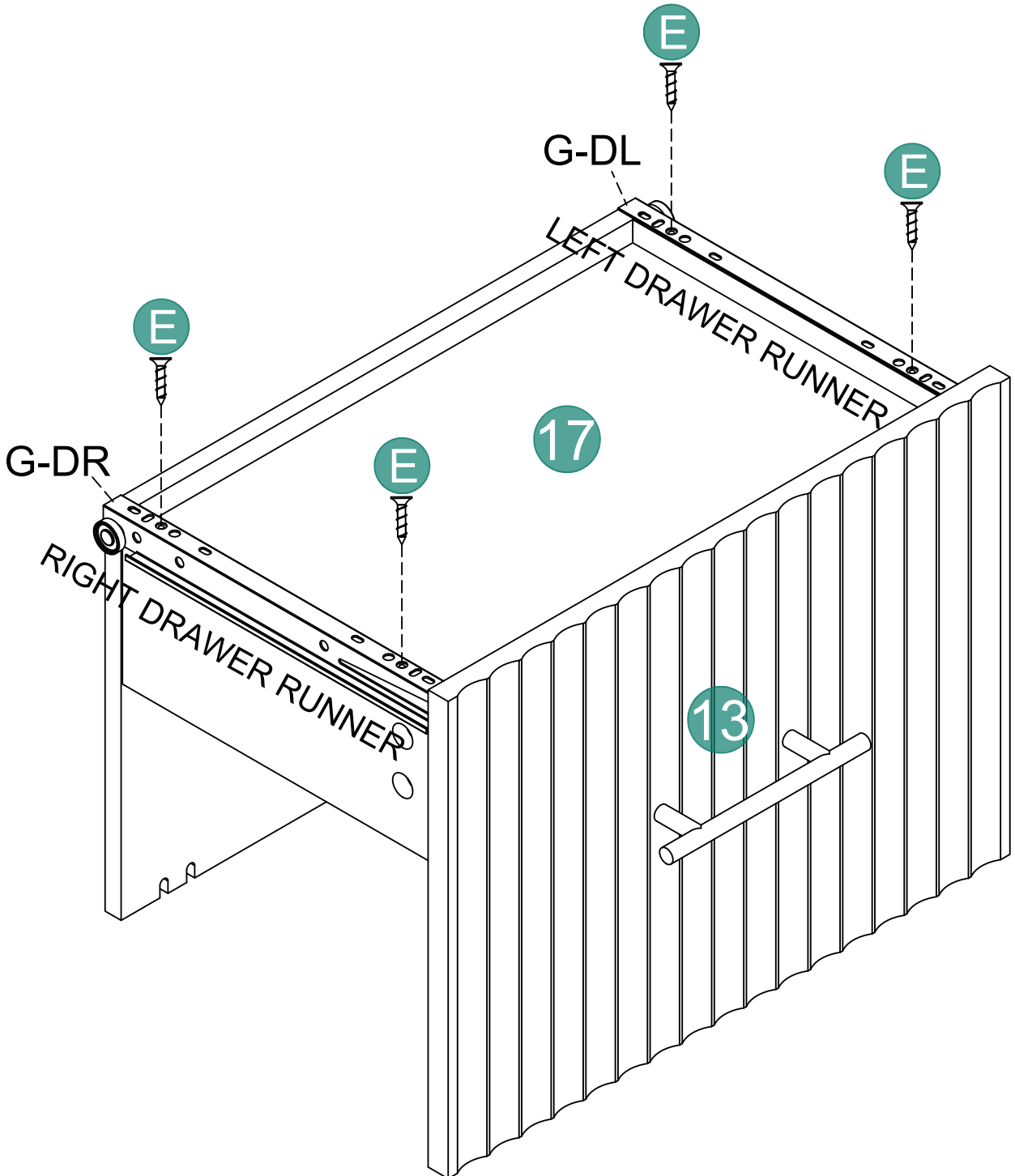

# 25



Ⓟ x2

There are two holes here;  
you can choose either one  
according to your needs.

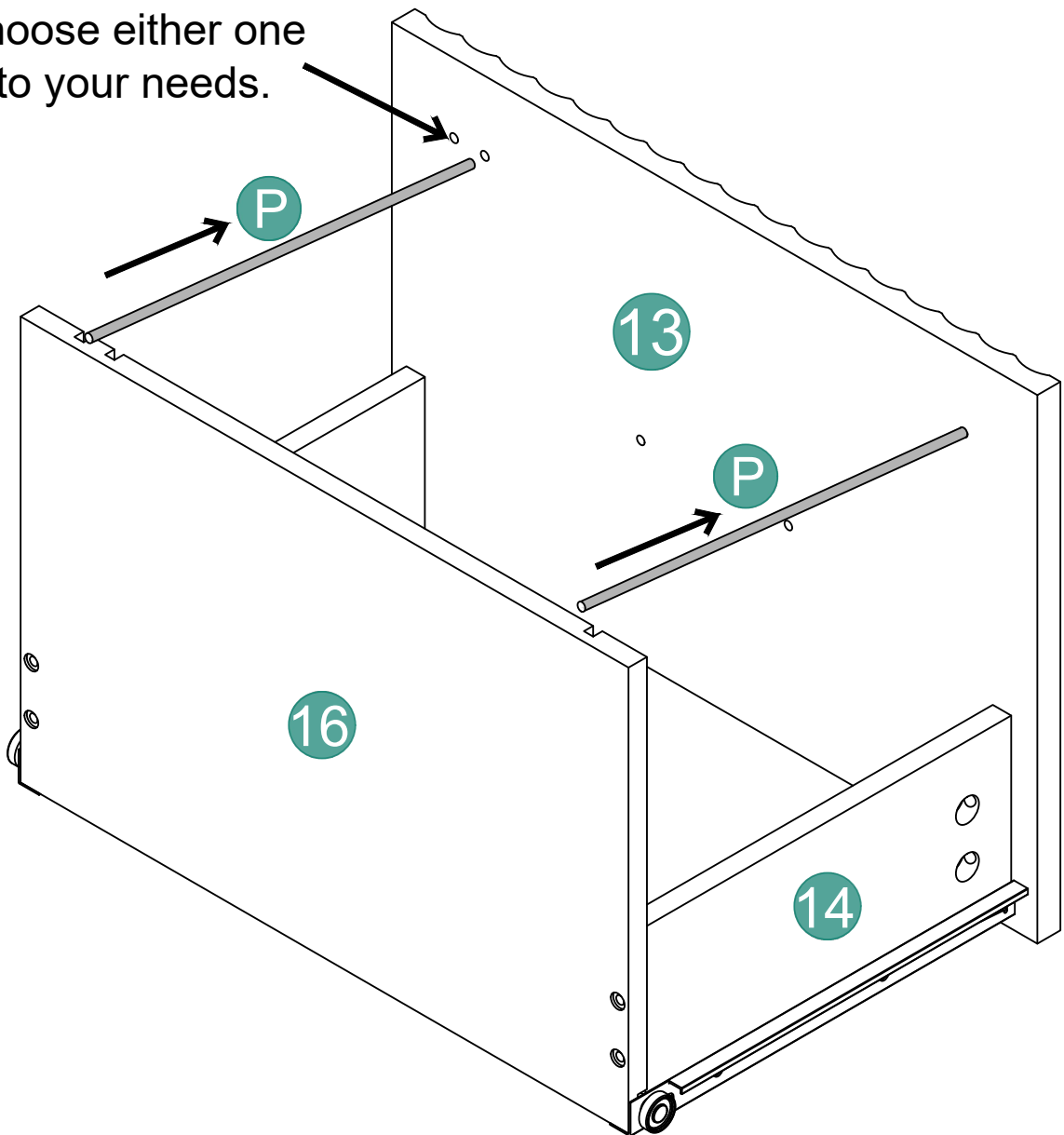

# 26

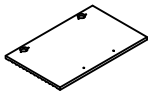

⑧ X1

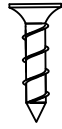

ⓔ X4



Ⓜ X1



Ⓝ X2

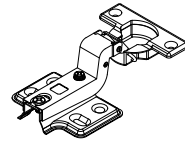

ⓗ X2

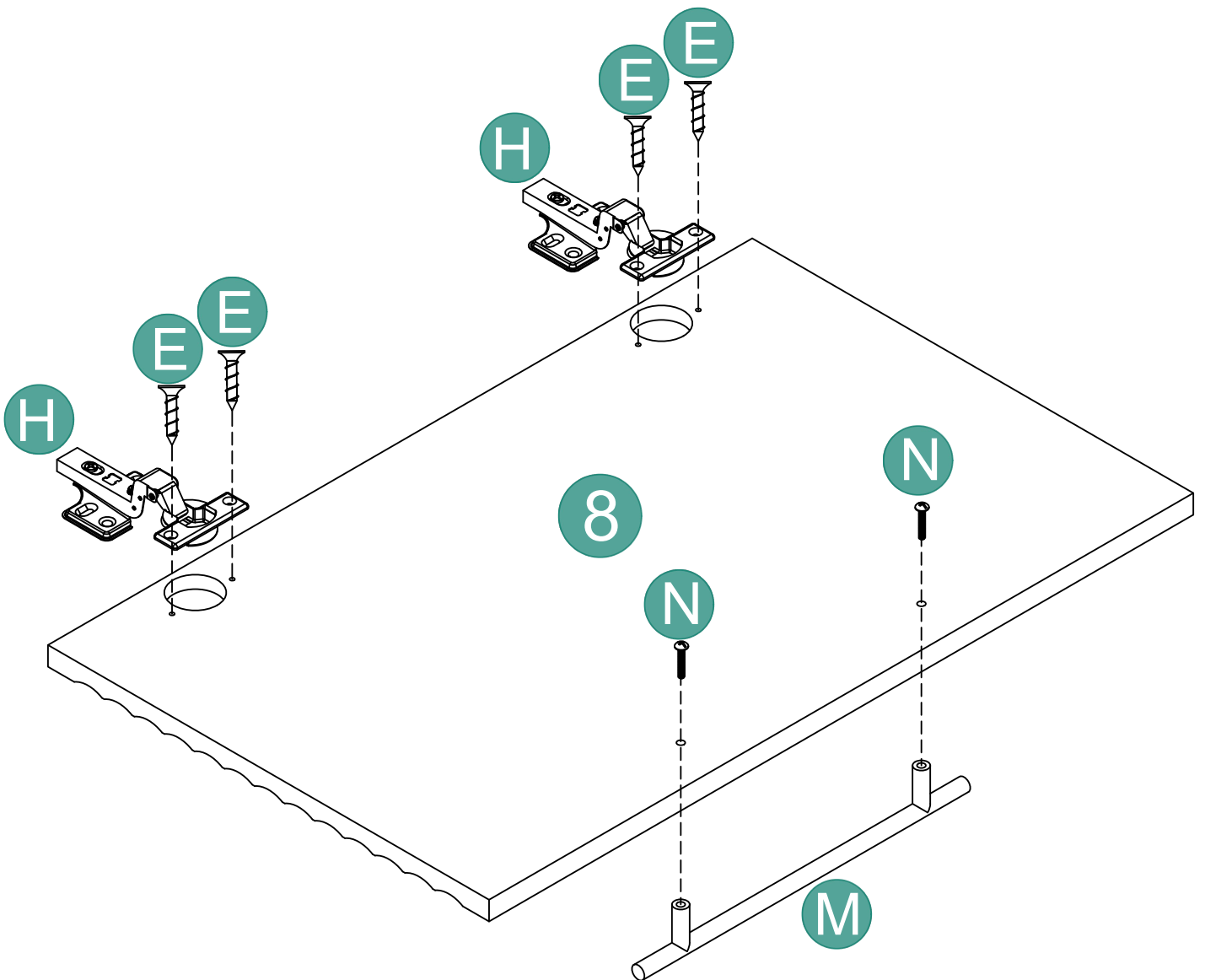

27

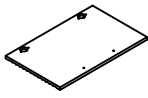

⑧ X1

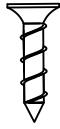

ⓔ X4

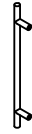

Ⓜ X1



Ⓝ X2

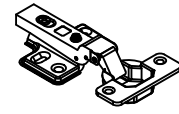

Ⓢ X2

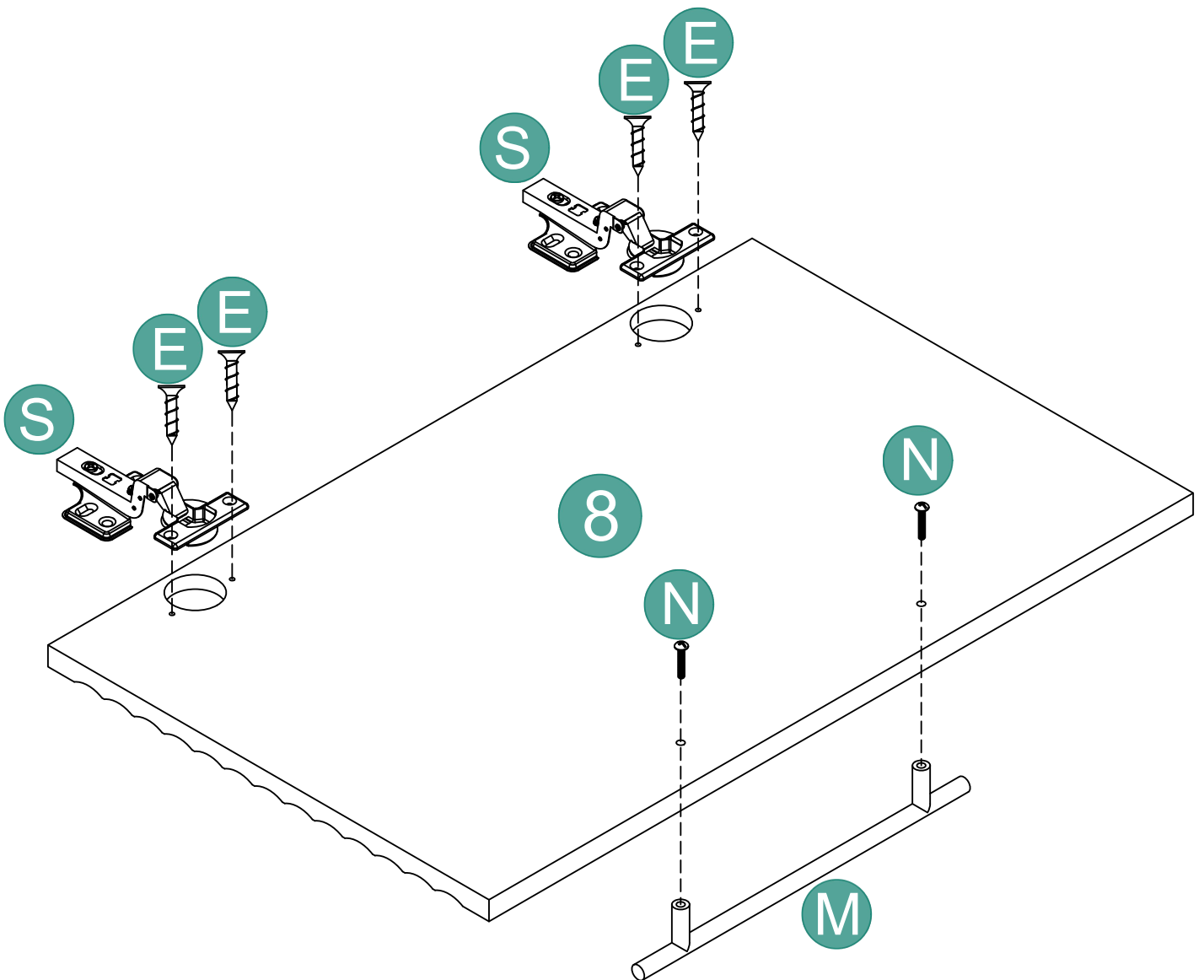

28

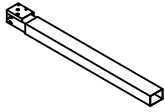

BB X1

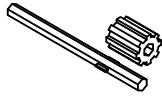

LL X1

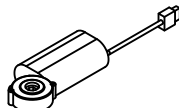

MM X1

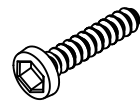

NN X2

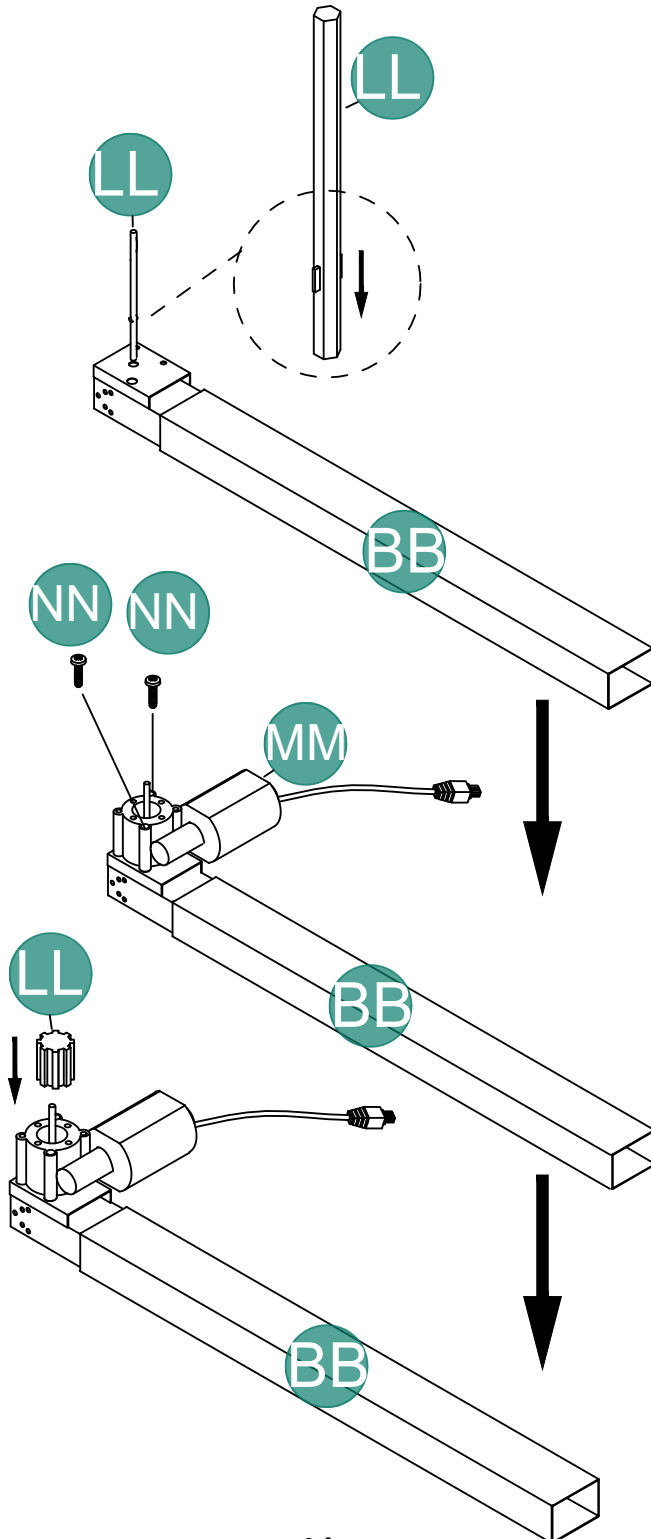

# 29

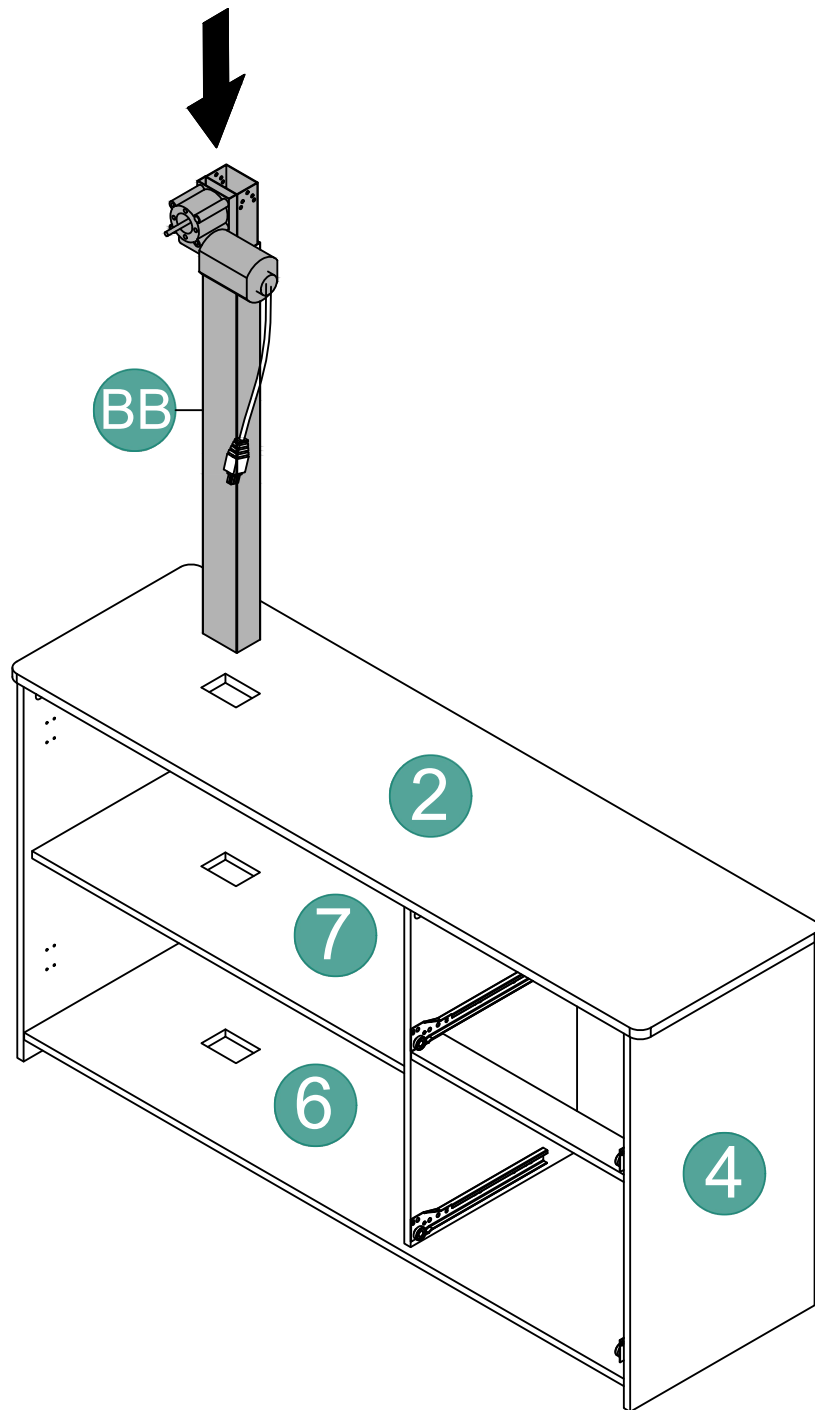

30

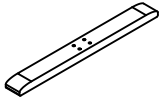

EE X1

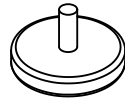

II X2

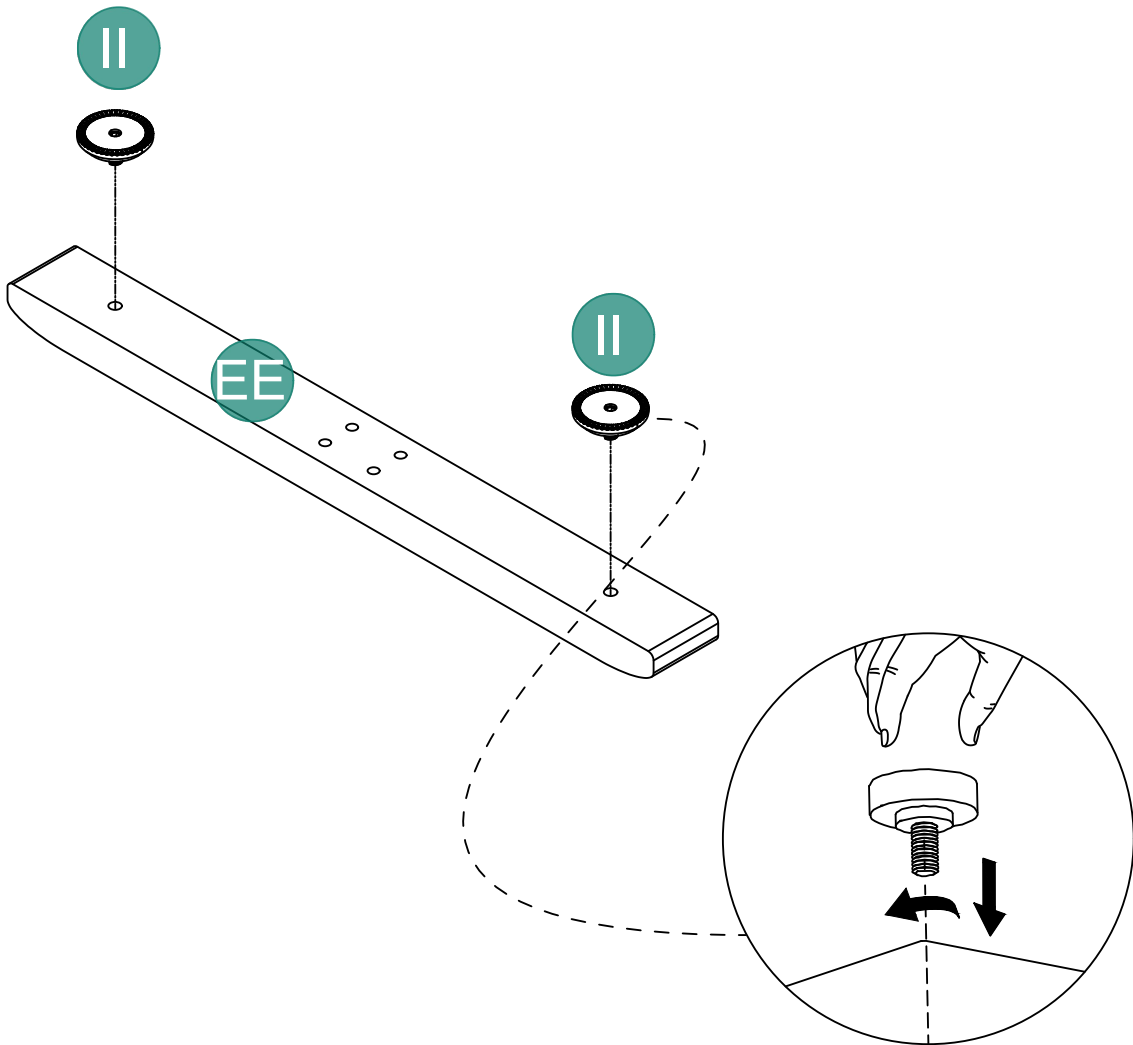

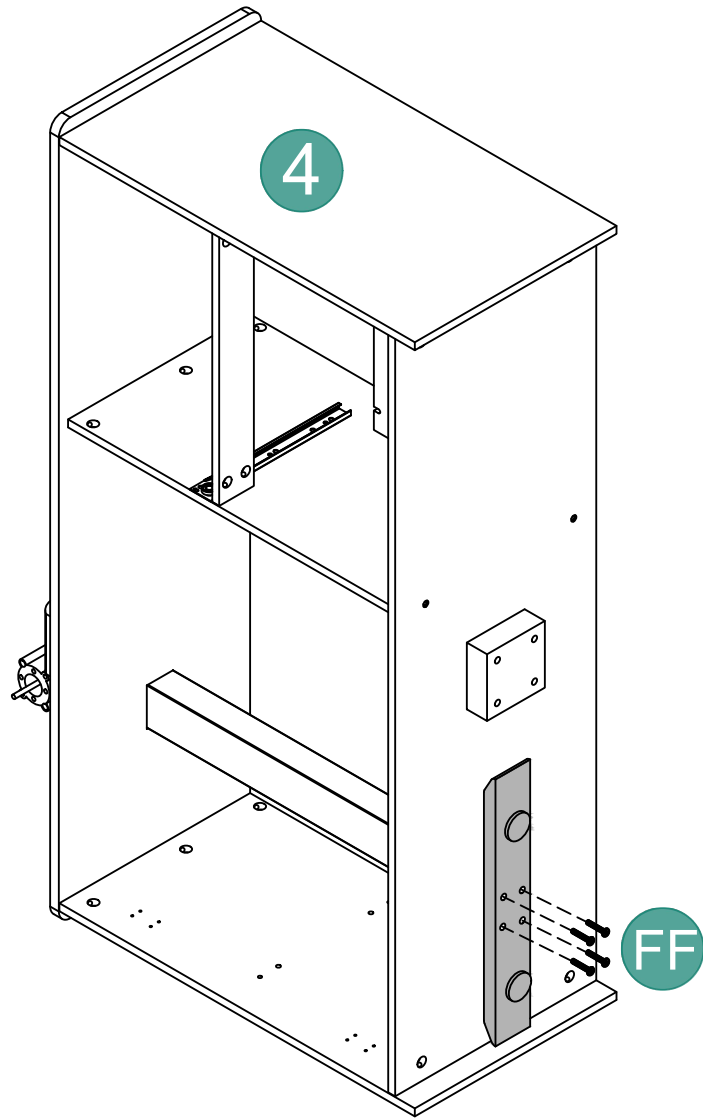
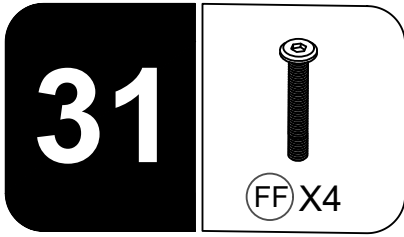

32



ⓔ X8

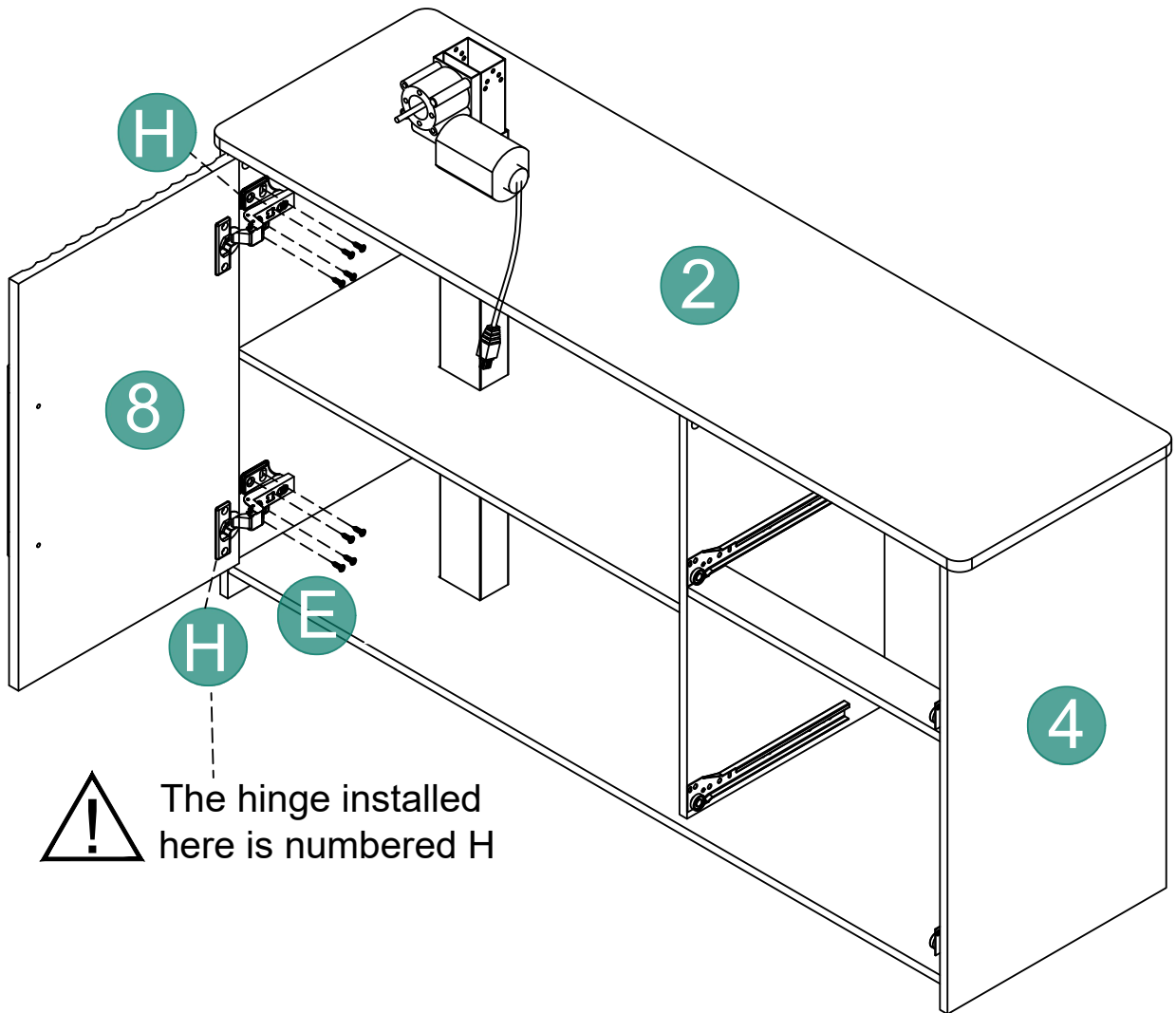

The hinge installed here is numbered H

33



(E) X8



The hinge installed here is numbered S

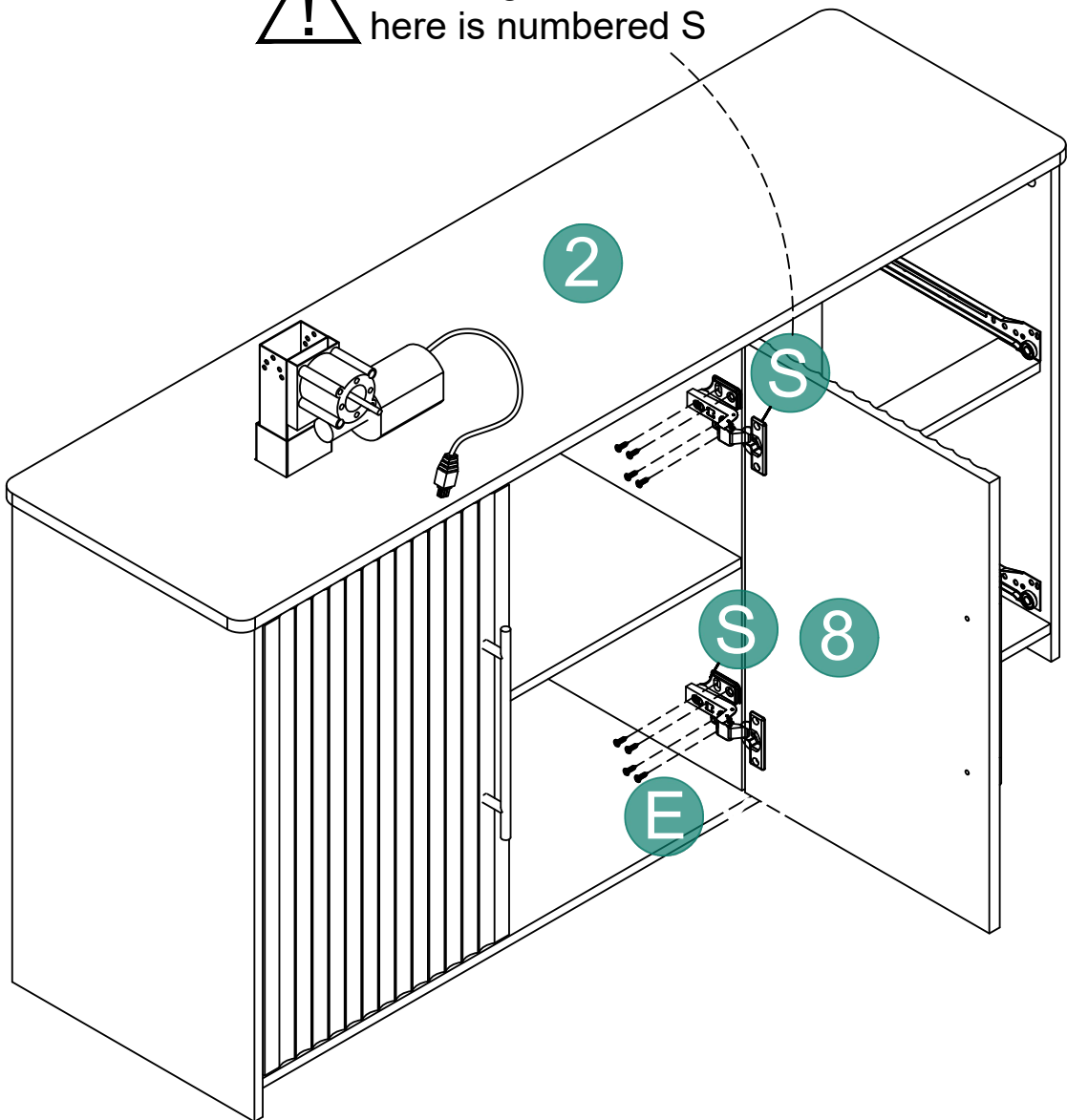

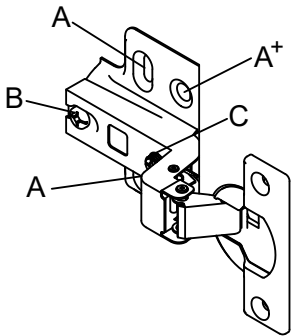

**NOTE:** If you encounter a gap or difficulty closing the door after installation, please adjust the hinge according to the following operation.

The method is as follows:

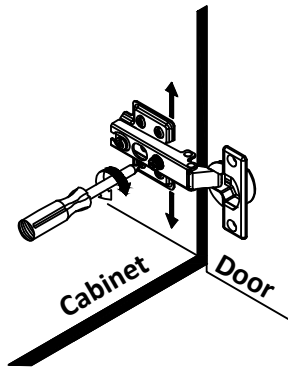
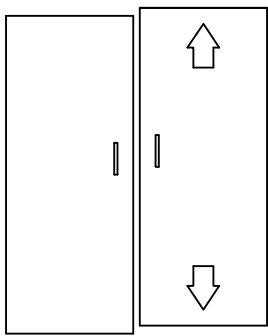

[ How to adjust vertical height of the door ]

- First remove the 2 screws "A+" on the hinge.
- Then loosen the 2 screws "A" on the hinge so that it can be adjusted up or down a few millimeters.
- Then tighten "A" and reinstall "A+".

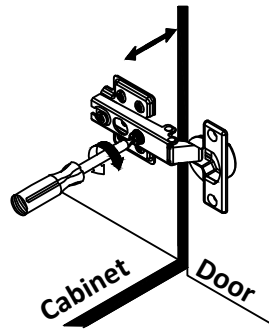
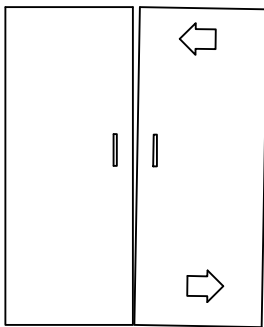

[ How to adjust the level of the door ]

- Turn screw "C" on hinge to adjust the level of the door.

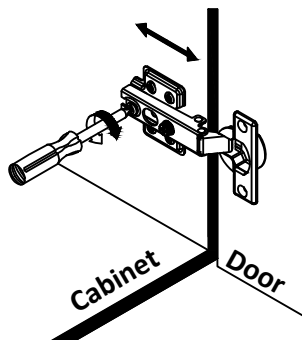
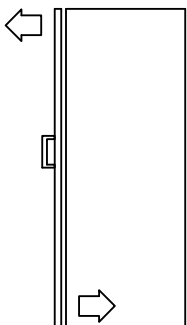

[ How to adjust depth of the door ]

- Loosen screw "B" and adjust the depth of the door.
- If screw "B" is loose, the depth of the door still cannot be adjusted. Simply loosen the screw "C" slightly to adjust the position of the door forward and backward.
- After adjusting the position, tighten screw "B" last.

34

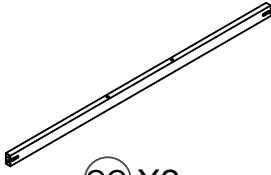

CC X2



GG X8

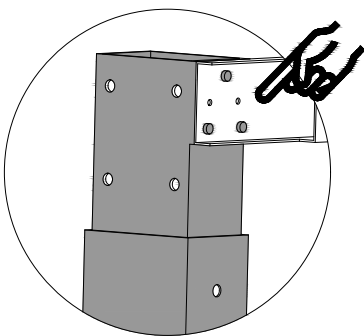
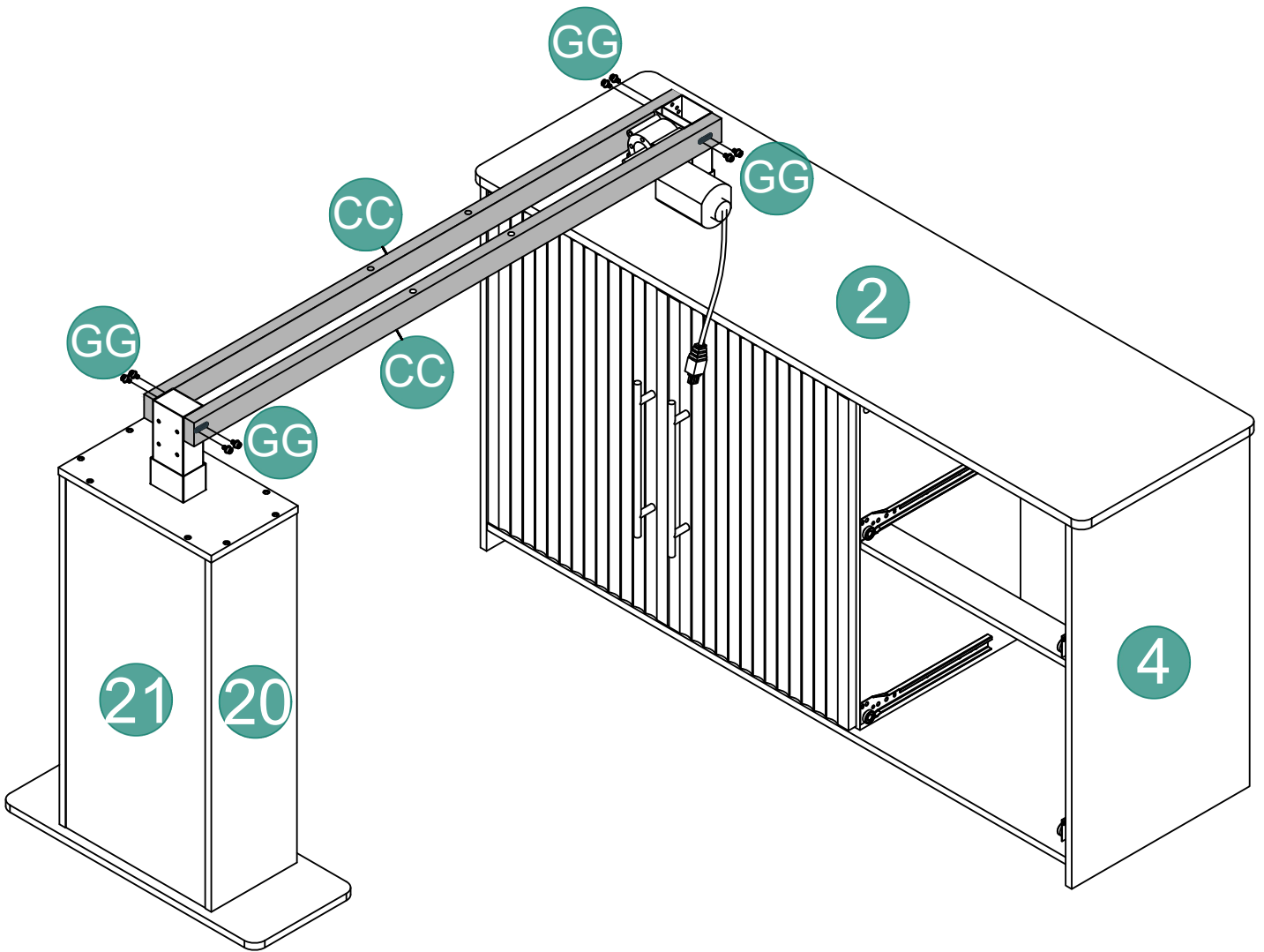

35

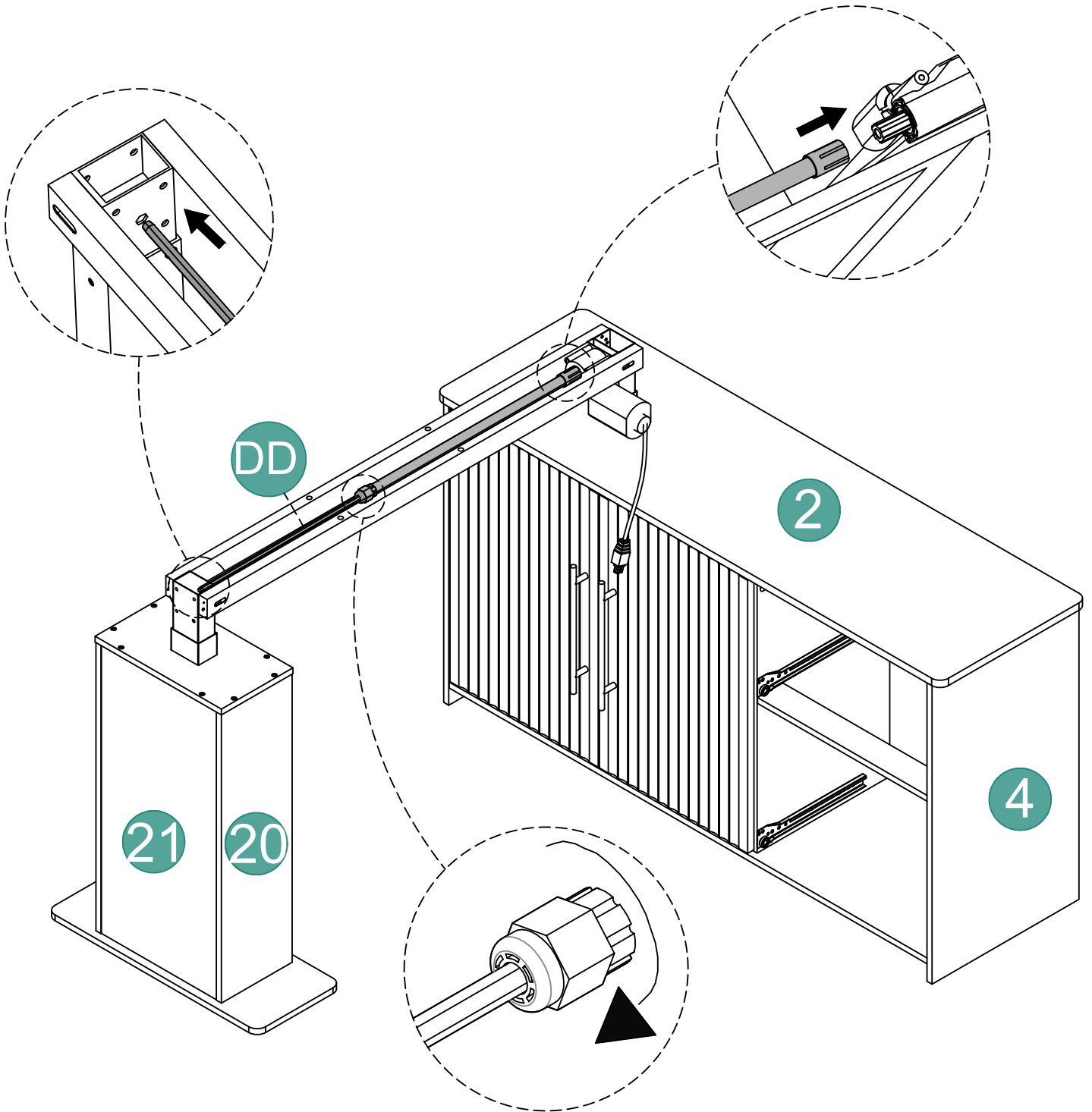
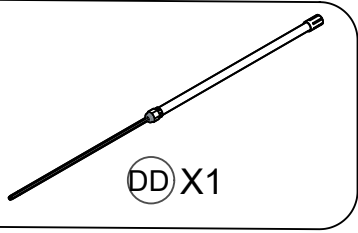

36



GG X4

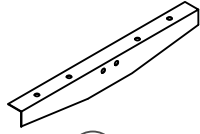

HH X2

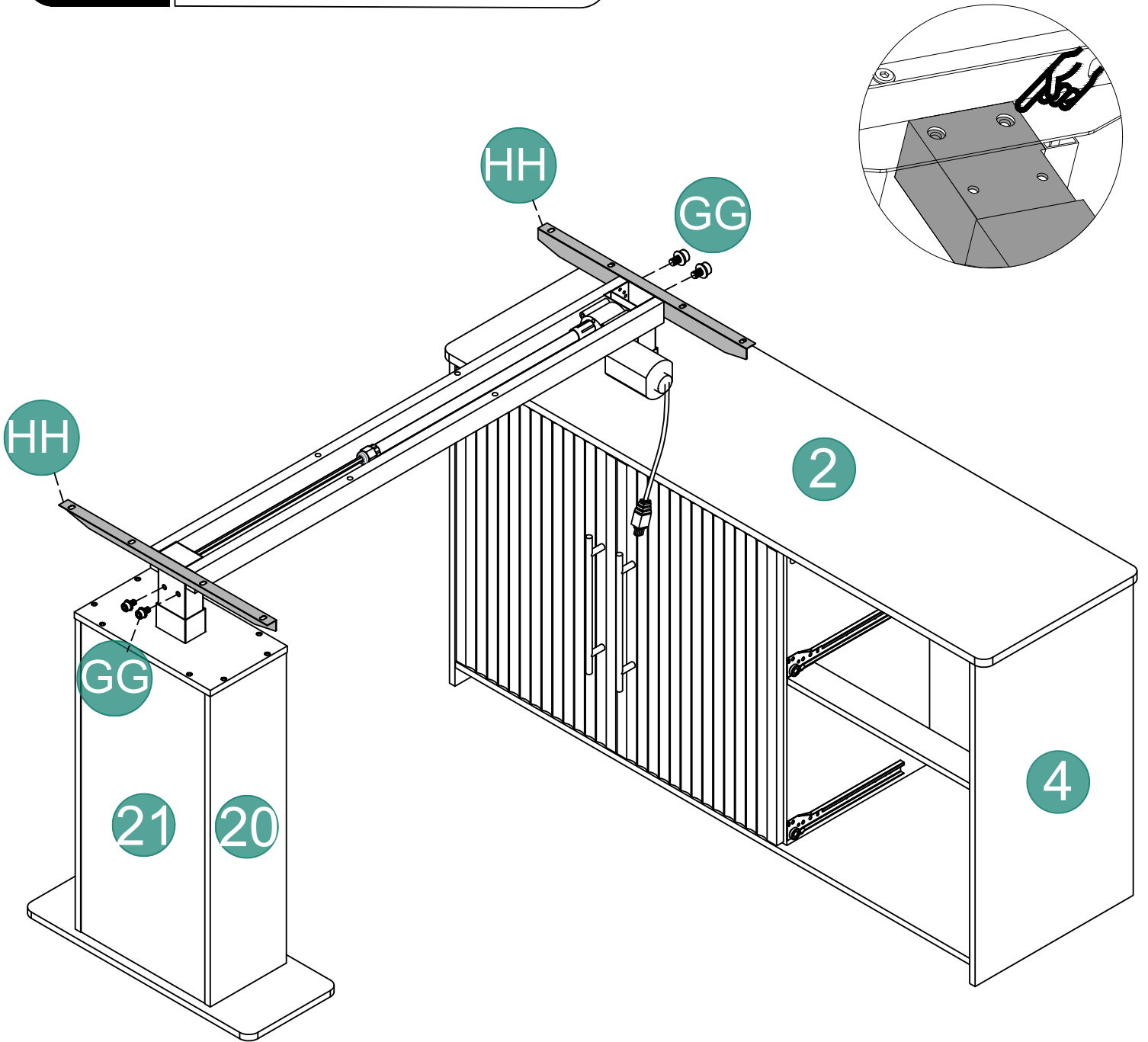

# 37

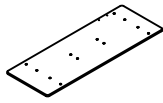

① X1



J X8



K X4

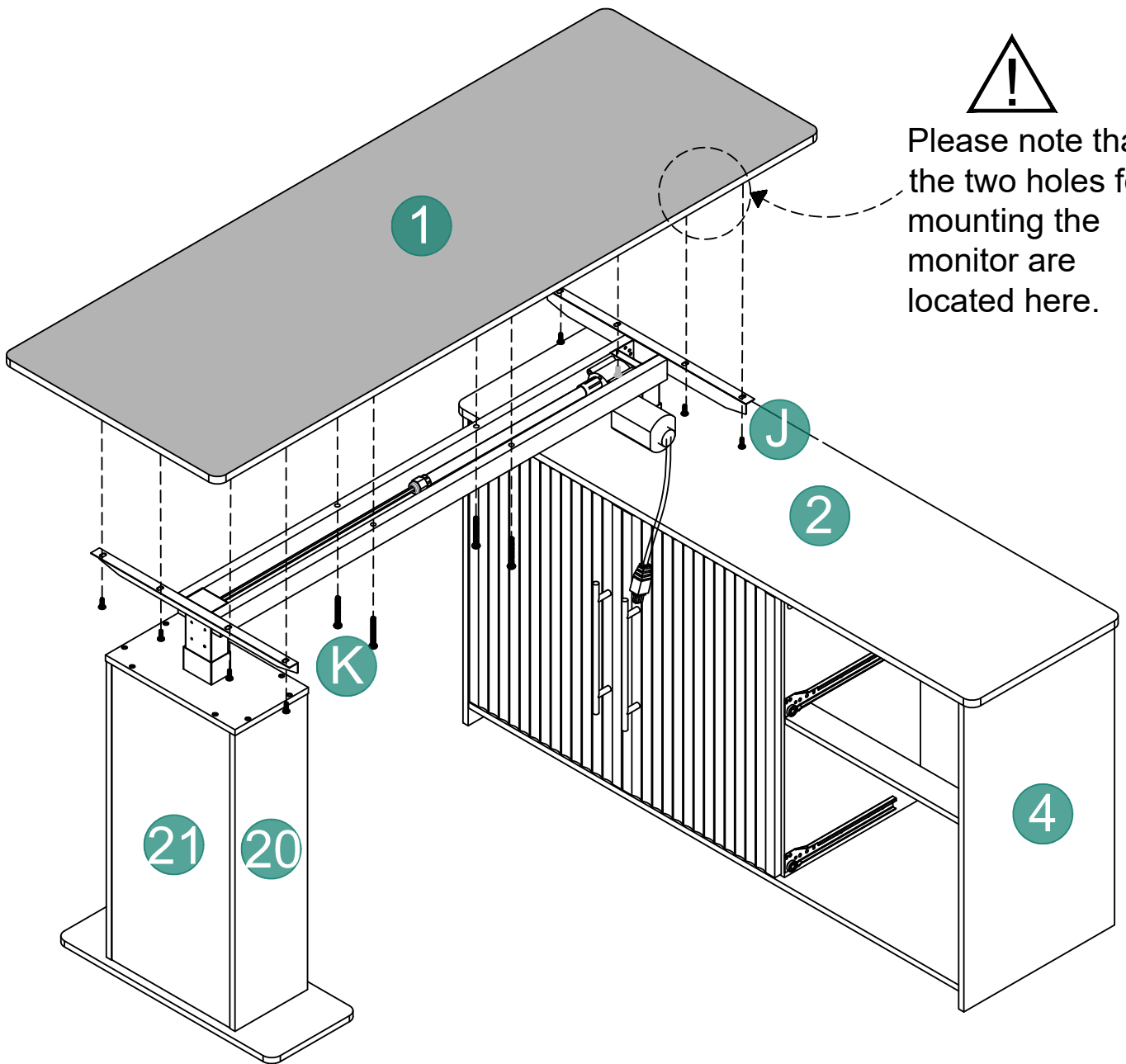

Please note that the two holes for mounting the monitor are located here.

38

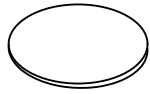

⊙X41

Using Cover-up Sticker  
(O)\*41 to cover the exposed  
part of Screws.

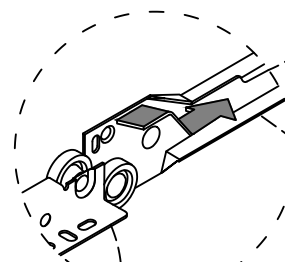
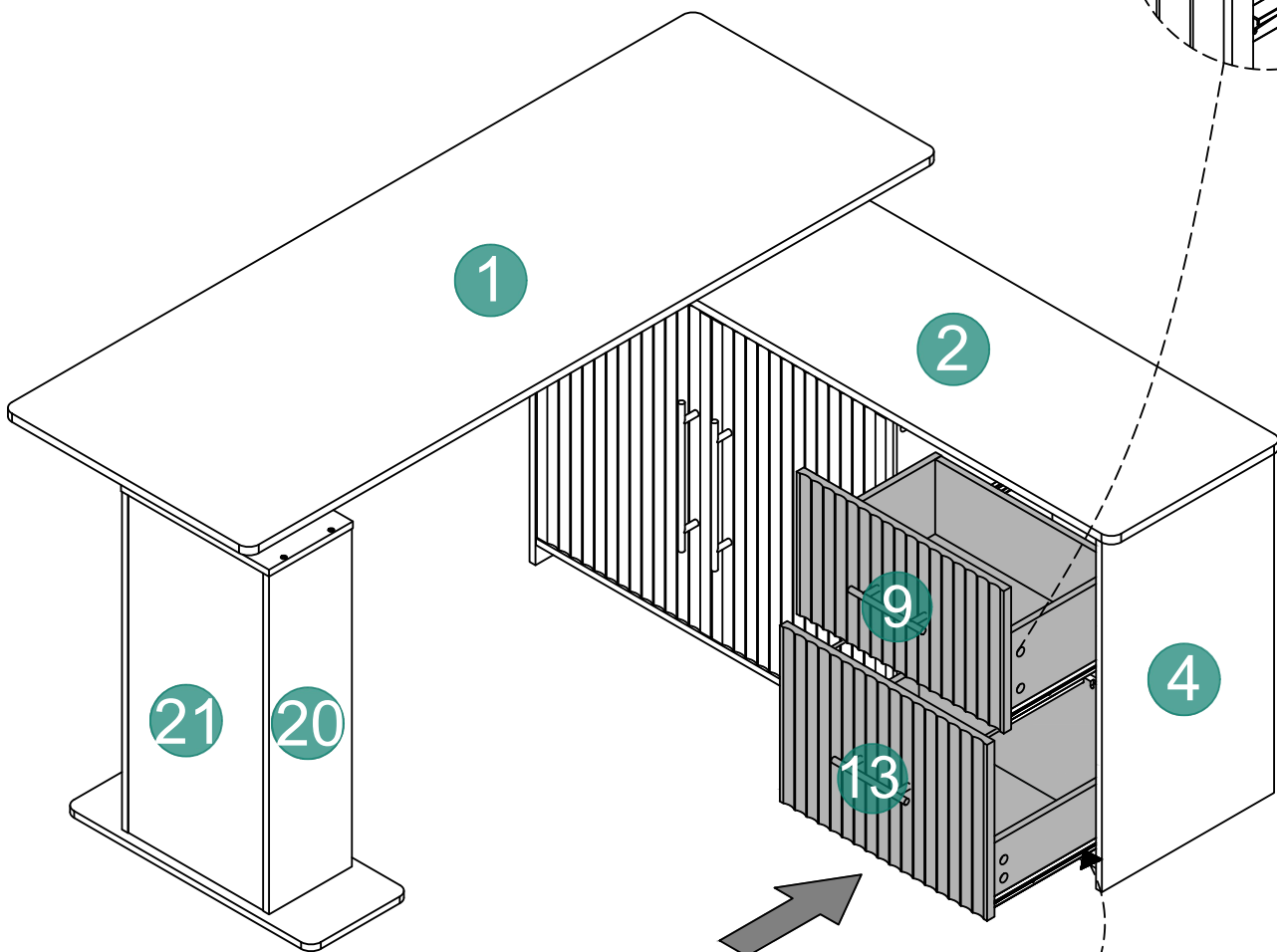
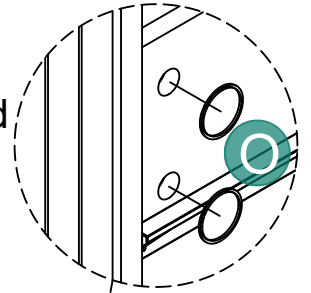

Cabinet Slide

Drawer Slide

39

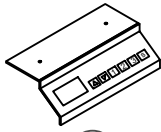

JJ X1



KK X1

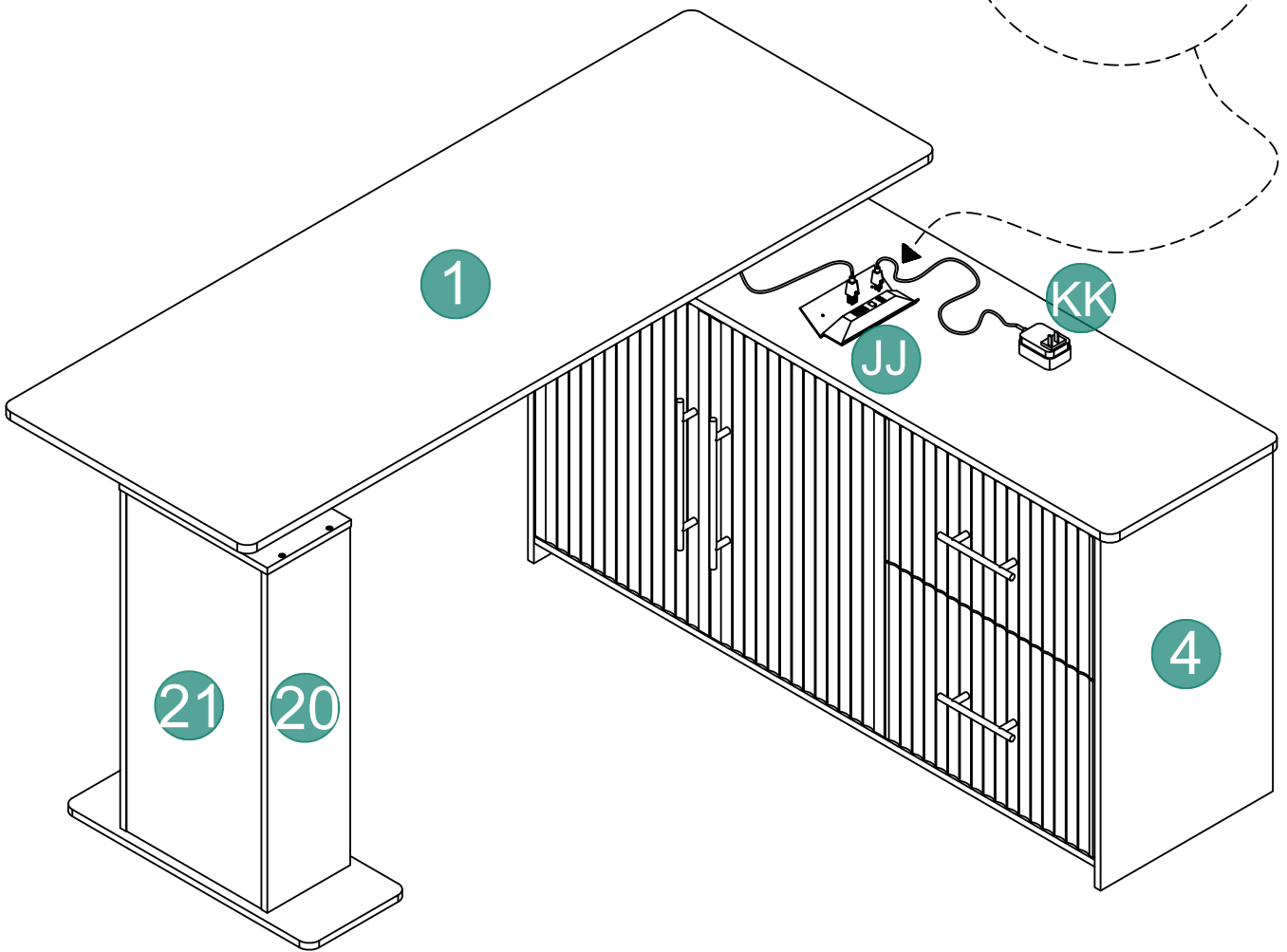
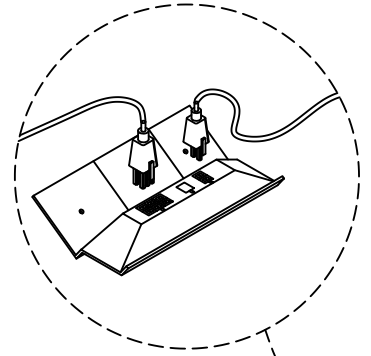

# 40



(F) X2

Secure accessory JJ to board 1 with screw F.

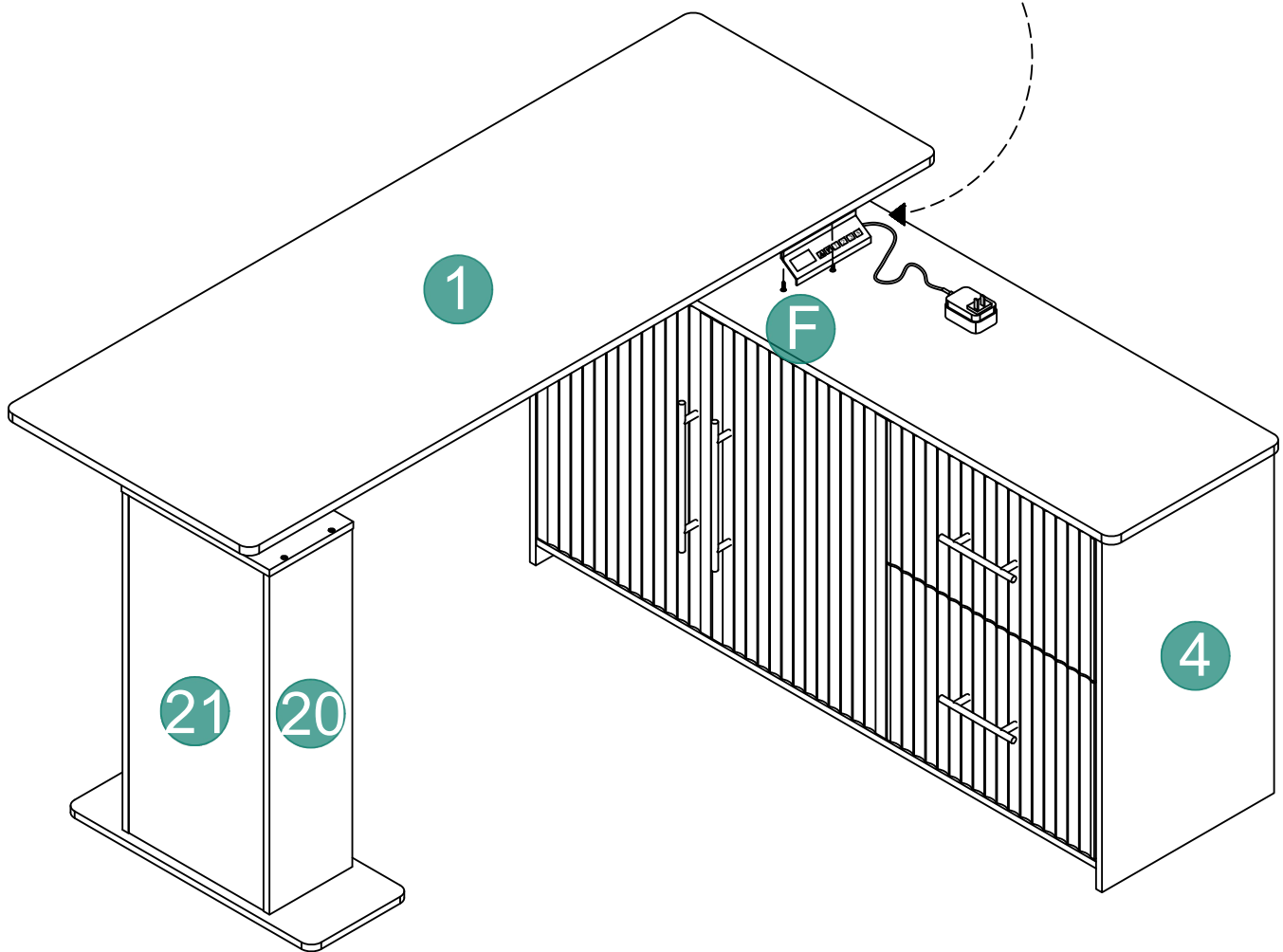

For easier installation, you can connect the lifting frame to the power supply at this step and slightly lift board number 1.

# 41

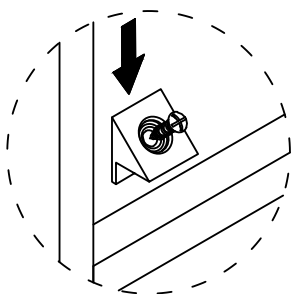
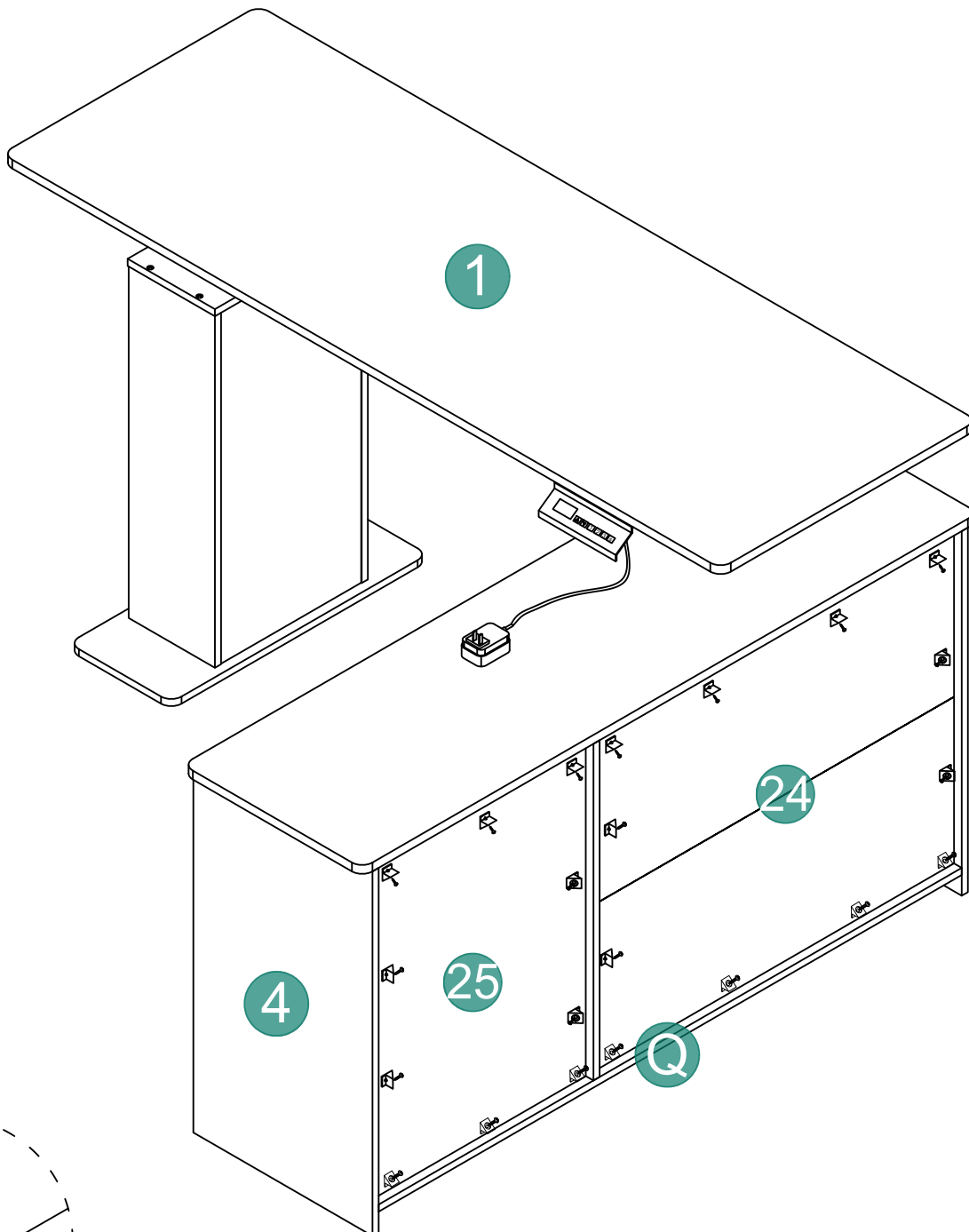



Insert the plastic buckle into the back plate slot, screw through the hole in the plastic buckle and lock it in place.

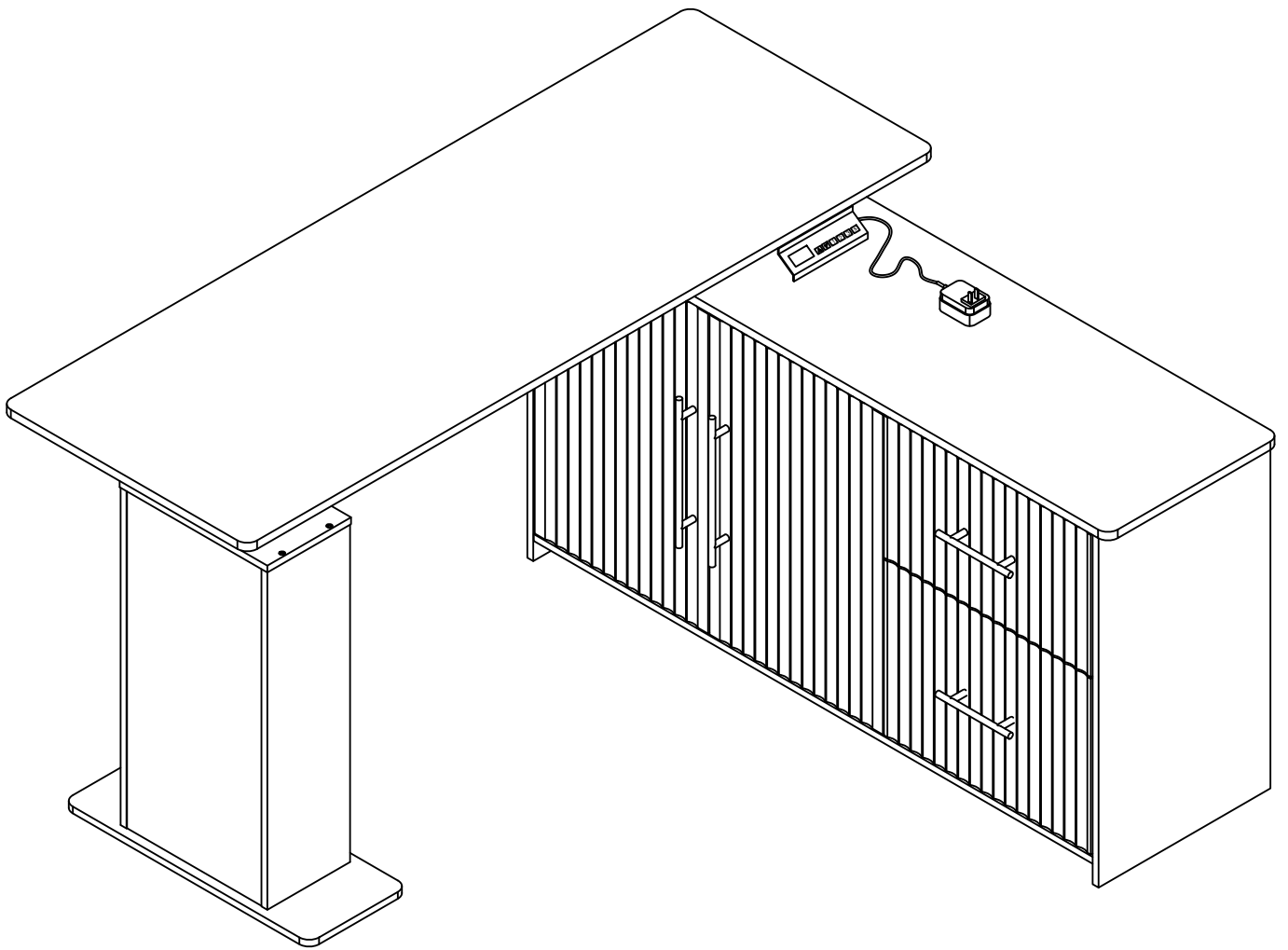

42



# Operation instructions for the elevating table manual controller

## 一. Table lifting

Hold down  the key  or key to control the table to rise or fall.

Hold the  key to control the lifting table to rise, you can see the increase of height (displayed number ) on the three-digit display; hold the key to control the lifting table to fall, you can see the decrease of height (displayed number) on the three-digit display.

## 二. the invocation and setting of memory height

In the height display interface, short press the number key and release it to call its corresponding height, and the lifting table will automatically run to the corresponding position.

In the height display interface, if you hold down the number key for more than two seconds, the current height can be recorded to the corresponding position.

## 三. Screen off wake up

If there is no key operation within 30 seconds, the digital tube will be automatically extinguished.



At this time, you can press any key to light up the digital tube.

## 四. Protection and alarm

1. Obstacle Protection: Display "E02". When the table vibrates, is bumped, or tilts during movement, it will trigger an alarm and immediately stop the motion. The motion will automatically stop after reaching the preset distance in reverse, or you can stop and discontinue the motion by pressing any key during the reverse operation. Ensure that the table does not vibrate significantly, bump into obstacles, or tilt during operation.
2. Overheat protection: "Hot" is displayed. This protection may be activated after a long period of continuous operation. Power on again or wait at least 15 minutes before using it.
3. Abnormal protection of the motor: "E10" is displayed. Power off, check and ensure that the connection between the motor and the controller is reliable, and then power on again.

3. Abnormal protection of the motor: "E10" is displayed. Power off, check and ensure that the connection between the motor and the controller is reliable, and then power on again.
4. Overload protection: Display "E20". If this alarm occurs when running upwards, remove some heavy objects on the table and run again; if this alarm occurs when running downwards, cut off the power, remove some heavy objects on the table, and then re-power.
5. Under-voltage protection: Display "E31". Power off, check and ensure that the connection between the power supply and the controller is reliable, and then power on again.
6. Overvoltage protection: Display "E32". Power off, recheck and ensure that the connection between the power supply and the controller is reliable, and then power on again.

## 六. Reset the itinerary

In the "E10, E20" alarm state or after running to the lowest height  position, hold down  the button for 5 seconds, display (Reset) and release. The lifting table will start to run down to the bottom and bounce a certain height, and the reset is completed and the lowest height is displayed.